Natural rubber latex male condoms — Requirements and test methods

Préservatifs masculins en latex de caoutchouc naturel — Exigences et méthodes d'essai





COPYRIGHT PROTECTED DOCUMENT

© ISO 2015, Published in Switzerland

All rights reserved. Unless otherwise specified, no part of this publication may be reproduced or utilized otherwise in any form or by any means, electronic or mechanical, including photocopying, or posting on the internet or an intranet, without prior written permission. Permission can be requested from either ISO at the address below or ISO's member body in the country of the requester.

ISO copyright office
Ch. de Blandonnet 8 • CP 401
CH-1214 Vernier, Geneva, Switzerland
Tel. +41 22 749 01 11
Fax +41 22 749 09 47
copyright@iso.org
www.iso.org

Licensed to Jack Wang (jack.wang@rb.com)
ISO Store Order: OP-96957 / Downloaded: 2015-10-20
Single user licence only, copying and networking prohibited

Contents

	Page
Foreword	v
Introduction	vii
1 Scope	1
2 Normative references	1
3 Terms and definitions	1
4 Quality verification	3
5 Lot size	3
6 Biocompatibility	4
7 Microbial contamination	4
8 Product claims	4
9 Design	4
9.1 Integral bead.....	4
9.2 Lubrication.....	4
9.3 Dimensions.....	5
9.3.1 Length.....	5
9.3.2 Width.....	5
9.3.3 Thickness.....	5
10 Bursting volume and pressure	5
11 Stability and shelf life	6
11.1 General.....	6
11.2 Minimum stability requirements.....	6
11.3 Procedure for determining shelf life by real-time stability studies.....	7
11.4 Estimating shelf life based upon accelerated stability studies.....	7
12 Freedom from holes	7
13 Visible defects	8
14 Package integrity of individual container	8
15 Packaging and labelling	8
15.1 Packaging.....	8
15.2 Labelling.....	8
15.2.1 General.....	8
15.2.2 Symbols.....	8
15.2.3 Individual container.....	8
15.2.4 Consumer package.....	9
15.2.5 Condoms not distributed in consumer packages.....	11
15.3 Inspection.....	11
16 Test report	11
Annex A (normative) Sampling plans intended for assessing compliance of a continuing series of lots of sufficient number to allow the switching rules to be applied	12
Annex B (informative) Sampling plans intended for assessing compliance of isolated lots	14
Annex C (normative) Determination of total lubricant for condoms in individual containers	16
Annex D (normative) Determination of length	20
Annex E (normative) Determination of width	22
Annex F (normative) Determination of thickness	23
Annex G (informative) Determination of microbial contamination	26

Annex H (normative) Determination of bursting volume and pressure	31
Annex I (normative) Oven treatment for condoms	33
Annex J (informative) Determination of force and elongation at break of test pieces of condoms	34
Annex K (normative) Determination of shelf life by real-time stability studies	37
Annex L (informative) Guidance on conducting and analysing accelerated ageing studies	40
Annex M (normative) Testing for holes	42
Annex N (normative) Testing for package integrity	48
Annex O (informative) Calibration of air inflation equipment for determination of bursting volume and pressure	50
Annex P (informative) Recommendations for testing condoms that fall outside of the size ranges specified in ISO 4074	54
Bibliography	56

Foreword

ISO (the International Organization for Standardization) is a worldwide federation of national standards bodies (ISO member bodies). The work of preparing International Standards is normally carried out through ISO technical committees. Each member body interested in a subject for which a technical committee has been established has the right to be represented on that committee. International organizations, governmental and non-governmental, in liaison with ISO, also take part in the work. ISO collaborates closely with the International Electrotechnical Commission (IEC) on all matters of electrotechnical standardization.

The procedures used to develop this document and those intended for its further maintenance are described in the ISO/IEC Directives, Part 1. In particular the different approval criteria needed for the different types of ISO documents should be noted. This document was drafted in accordance with the editorial rules of the ISO/IEC Directives, Part 2 (see www.iso.org/directives).

Attention is drawn to the possibility that some of the elements of this document may be the subject of patent rights. ISO shall not be held responsible for identifying any or all such patent rights. Details of any patent rights identified during the development of the document will be in the Introduction and/or on the ISO list of patent declarations received (see www.iso.org/patents).

Any trade name used in this document is information given for the convenience of users and does not constitute an endorsement.

For an explanation on the meaning of ISO specific terms and expressions related to conformity assessment, as well as information about ISO's adherence to the WTO principles in the Technical Barriers to Trade (TBT) see the following URL: [Foreword - Supplementary information](#)

The committee responsible for this document is ISO/TC 157, *Non-systemic contraceptives and STI barrier prophylactics*.

This third edition cancels and replaces the second edition (ISO 4074:2014), which has been technically revised. The modifications are as follows:

- a) The maximum lot size has been limited to 500 000.
- b) Specific requirements for biocompatibility assessments, as defined in ISO 10993-1, have been added.
- c) It is recommended that manufacturers establish procedures for the periodic monitoring of microbial contamination (bioburden) as part of their quality management system including requirements for the absence of specific pathogens and limits for total viable counts on finished condoms; methods of determining bioburden levels on condoms are given in [Annex G](#).
- d) Specific requirements for extra strength condoms have been deleted but there is now a general requirement for manufacturers to justify any additional claims made for their products; claims relating to improved efficacy or safety have to be substantiated by clinical investigation.
- e) A minimum airburst volume of 28,0 dm³ has been introduced for condoms with mid-body widths that are greater than or equal to 65,0 mm and not more than 75,0 mm.
- f) The radius of the inner edge of the clamping collar wherever it contacts the inflated condom has to be a minimum of 2 mm ([Annex H](#)).
- g) The volumes of electrolyte used in the electrical test for determining freedom from holes described in [Annex M](#) have been brought into line with the volumes used for the water leak test.
- h) The volumes of water or electrolyte specified in the freedom from holes test have been increased for condoms that have mid-body widths greater than or equal to 56 mm and/or are longer than 210 mm.
- i) When conducting the electrical test for freedom from holes, the voltage is now measured from the time that the condom is first immersed and for up to 10 s after full immersion.

- j) The method of testing for freedom from holes specified in ASTM D3492[8] has been included by reference.
- k) A limit has been introduced for the number of individual containers with visibly open seals, to be evaluated when the containers are inspected during the freedom from holes test described in [Annex M](#).
- l) Recommended requirements for minimum airburst properties and freedom from holes testing for condoms narrower than 45 mm and/or shorter than 160 mm have been introduced in informative [Annex P](#) to provide guidance to regulatory authorities, notified bodies and other interested parties when assessing condoms that fall outside of the normative size range specified in this International Standard.
- m) Amendments have been made to the methods for determining the shelf life of condoms including a simplified procedure for determining the shelf life by accelerated stability studies based on fixed ageing periods at 50 °C.
- n) Testing for freedom from holes, airburst properties, and package integrity are required when conducting stability studies to establish that condoms meet the minimum stability requirements specified in this International Standard and when determining condom shelf lives.
- o) The procedure for determining the thickness of a condom by the micrometer method is described in detail.
- p) An alternative method of removing the lubricant from the condom using an aqueous surfactant solution has been introduced into the method for determining the amount of lubricant on the condom.
- q) Revisions have been made to labelling requirements including the additional information supplied with the condom.

Regulatory agencies, notified bodies, and purchasers should consider the need for a transition period when implementing the requirements of this International Standard to allow manufacturers to make the changes required to maintain compliance. This applies particularly to the changes in packaging and labelling specified in [Clause 15](#).

Introduction

Condoms made from intact latex film have been shown to be a barrier to human immunodeficiency virus (HIV), other infectious agents responsible for the transmission of sexually transmitted infections (STIs), and to spermatozoa. Numerous clinical studies have confirmed that male latex condoms are effective in helping to prevent pregnancy and reduce the risk of transmission of most STIs including HIV.

In order to help ensure that condoms are effective for contraceptive purposes and in assisting in the prevention of transmission of STIs, it is essential that condoms fit the penis properly, are free from holes, have adequate physical strength so as not to break during use, are correctly packaged to protect them during storage, and are correctly labelled to facilitate their use. All these issues are addressed in this International Standard.

Condoms are medical devices. To ensure high quality product, it is essential that condoms are produced under a good quality management system. See ISO 13485^[4] for quality management requirements and ISO 14971^[5] for risk management requirements.

Condoms are non-sterile medical devices but manufacturers are advised to take appropriate precautions to minimize microbiological contamination of the product throughout the manufacturing and packaging processes. Recommendations for manufacturers to periodically monitor microbial contamination during production are included in this International Standard. Methods that can be used to determine bioburden levels are included in [Annex G](#).

This International Standard requires manufacturers to conduct stability tests to estimate the shelf life of any new or modified condom before the product is placed on the market and to initiate real-time stability studies. These requirements are described in [Clause 11](#). The real-time stability test can be considered as part of the manufacturers' requirement to conduct post-marketing surveillance on their products. These requirements are intended to ensure that manufacturers have adequate data to support shelf life claims before products are placed on the market and that these data are available for review by regulatory authorities, third party test laboratories, and purchasers. They are also intended to limit the need for third parties to conduct long-term stability studies.

Condoms might be subject to specific local requirements as required by national regulatory bodies in addition to those specified in this International Standard.

ISO 16038^[6] provides guidance for the application of this International Standard. It includes additional information on the test methods and requirements specified in this International Standard.

Natural rubber latex male condoms — Requirements and test methods

1 Scope

This International Standard specifies requirements and test methods for male condoms made from natural rubber latex.

2 Normative references

The following documents, in whole or in part, are normatively referenced in this document and are indispensable for its application. For dated references, only the edition cited applies. For undated references, the latest edition of the referenced document (including any amendments) applies.

ISO 2859-1, *Sampling procedures for inspection by attributes — Part 1: Sampling schemes indexed by acceptance quality limit (AQL) for lot-by-lot inspection*

ISO 10993-1, *Biological evaluation of medical devices — Part 1: Evaluation and testing within a risk management process*

ISO 10993-5, *Biological evaluation of medical devices — Part 5: Tests for in vitro cytotoxicity*

ISO 10993-10, *Biological evaluation of medical devices — Part 10: Tests for irritation and skin sensitization*

ISO 15223-1, *Medical devices — Symbols to be used with medical device labels, labelling and information to be supplied — Part 1: General requirements*

ISO 15223-2, *Medical devices — Symbols to be used with medical device labels, labelling, and information to be supplied — Part 2: Symbol development, selection and validation*

ISO/IEC 17025, *General requirements for the competence of testing and calibration laboratories*

3 Terms and definitions

For the purposes of this document, the terms and definitions given in ISO 2859-1 and the following apply.

3.1

acceptance quality limit

AQL

quality level that is the worst tolerable process average when a continuing series of lots is submitted for acceptance sampling

[SOURCE: ISO 2859-1:1999, 3.1.26]

3.2

male condom

medical device used by consumers, which is intended to cover and be retained on the penis during sexual activity, for purposes of contraception and prevention of sexually transmitted infections

3.3

consumer package

package, intended for distribution to a consumer, containing one or more individual containers of condoms

3.4

expiry date

date after which the condom should not be used

3.5

identification number

number, or combination of numerals, symbols, or letters, used by a manufacturer on consumer packages to identify uniquely the lot numbers of individual condoms contained in that package, and from which it is possible to trace those lots through all stages of manufacturing, packaging, and distribution

Note 1 to entry: When the consumer package contains only one type of condom, then the identification number may be the same as the lot number; but if the consumer package contains several different types of condoms, for instance condoms of different shapes or colours, then the identification number will be different from the lot numbers.

3.6

individual container

primary package containing a single condom

3.7

inspection level

index of the relative amount of inspection of an acceptance sampling scheme, chosen in advance, and relating the sample size to the lot size

[SOURCE: ISO 3534-2:2006, 4.3.5]

3.8

lot

collection of condoms of the same design, colour, shape, size, and formulation, manufactured at essentially the same time, using the same process, raw materials of the same specifications, common equipment, and packed with the same lubricant and any other additive or dressing in the same type of individual container

3.9

lot number

number, or combination of numerals, symbols, or letters, used by the manufacturer to identify a lot of individually packaged condoms, and from which it is possible to trace that lot through all stages of manufacture up to packaging

3.10

non-visible hole

hole in a condom that is not visible under normal or corrected vision but is detected by the water leak test or the electrical test described in this International Standard

3.11

sampling plan

specific plan which indicates the number of units of product from each lot which are to be inspected (sample size or series of sample sizes) and the associated criteria for determining the acceptability of the lot (acceptance and rejection numbers)

3.12

shelf life

period from date of manufacture during which condoms are required to conform to the requirements for bursting pressure, bursting volume, freedom from holes, and pack integrity specified in this International Standard

3.13

visible hole

hole in the condom that is visible under normal or corrected vision before the condom is filled with water or electrolyte during testing for freedom from holes

3.14**date of manufacture**

date specified by the manufacturer when the product was made subject to the requirements specified in [11.1](#)

3.15**visible defects (other than holes and tears)**

broken, missing, or severely distorted bead and permanent creases with adhesion of the film

4 Quality verification

Condoms are mass produced articles manufactured in very large quantities. Inevitably, there will be some variation between individual condoms, and a small proportion of condoms in each production run might not meet the requirements in this International Standard. Further, the majority of the test methods described in this International Standard are destructive. For these reasons the only practicable method of assessing conformity with this International Standard is by testing a representative sample from a lot or series of lots. Basic sampling plans are given in ISO 2859-1. Reference should be made to ISO/TR 8550[2] for guidance on the use of acceptance sampling system, scheme, or plan for the inspection of discrete items in lots. For testing purposes, sampling shall be conducted by lot number, not by identification number.

When on-going verification is required of the quality of condoms, it is suggested that, instead of concentrating solely on evaluation of the final product, attention is also directed at the manufacturer's quality system. In this connection, it should be noted that ISO 13485[4] covers the provision of an integrated quality system for the manufacture of medical devices.

Sampling plans shall be selected to provide an acceptable level of consumer protection. Suitable sampling plans are given in [Annexes A](#) and [B](#).

- a) [Annex A](#) describes sampling plans based on ISO 2859-1 and is most applicable to manufacturers or purchasers assessing the conformity of a continuing series of lots. The full level of consumer protection available depends upon the switch to tightened inspection if deterioration in quality is detected. The switching rules, described in ISO 2859-1:1999, Clause 9, cannot offer their full protection for the first two lots tested but become progressively more effective as the number of lots in a series increases. The sampling plans in [Annex A](#) are recommended when five or more lots are being tested.
- b) [Annex B](#) describes sampling plans, based on ISO 2859-1, that are recommended for the assessment of isolated lots. The sampling plans in [Annex B](#) provide approximately the same level of consumer protection as those given in [Annex A](#) when used with the switching rules. It is recommended that these sampling plans are used for the assessment of fewer than five lots, for example in cases of dispute, for referee purposes, for type testing, for qualification purposes, or for short runs of continuing lots.

It is necessary to know the lot size in order to derive from ISO 2859-1 the number of condoms to be tested. The lot size will vary between manufacturers and is regarded as part of the process and quality controls used by the manufacturer.

If the lot size is not known or cannot be confirmed by the manufacturer, then a lot size of 500 000 condoms shall be assumed for determining the sample sizes for testing.

5 Lot size

The maximum individual lot size for production shall be 500 000 condoms.

NOTE This International Standard does not specify the size of a lot, but it is possible for a purchaser to do so as part of the purchasing contract. Purchasers are encouraged to specify a lot size compatible with the manufacturer's quality management system.

6 Biocompatibility

For any new product or following a significant change to the formulation or manufacturing process, biocompatibility assessments shall be conducted in accordance with ISO 10993-1. Evaluation for cytotoxicity according to ISO 10993-5, irritation according to ISO 10993-10, and sensitization (delayed contact hypersensitivity) according to ISO 10993-10 shall be conducted. The condom together with any lubricant, additive, dressing material, or powder applied to it shall be evaluated.

The laboratory used for any testing shall comply with the requirements contained in ISO/IEC 17025. The results shall be interpreted by a qualified toxicologist or any other appropriately qualified expert. The biological assessment report shall justify that the product is safe for its intended use.

NOTE Many latex products that have been established as safe including condoms and medical gloves can exhibit a positive cytotoxic response when tested according to ISO 10993-5. While any cytotoxic effect can be of concern, it is primarily an indication of potential for *in vivo* toxicity and a condom cannot necessarily be determined to be unsuitable for use based solely on cytotoxicity data.

7 Microbial contamination

Manufacturers are recommended to establish procedures for the control and periodic monitoring of microbial contamination (bioburden) as part of their quality management system. *Staphylococcus aureus*, *Pseudomonas aeruginosa*, and *Enterobacteriaceae*, including *Escherichia coli*, are pathogenic organisms that can potentially be found on condoms and can cause urinary tract or other infections. It is recommended that these organisms are absent from condoms. The procedures should include requirements for absence of specific pathogens and limits for total viable counts on finished condoms. Methods of determining bioburden levels on condoms are given in [Annex G](#).

NOTE 1 General methods for determining microbial contamination on sterile medical devices are given in ISO 11737-1.^[3] It includes methods for validating testing (ISO 11737-1:2006, Annex C). The methods described in [Annex G](#) of this International Standard have been found to be suitable for use with condoms taking into account specific issues associated with testing these products. These issues include the residual antimicrobial activity of some of compounds used in latex formulations which can interfere with the assays.

NOTE 2 To control microbial contamination on the finished product, manufacturers need to control the manufacturing environment to reduce the risk of contaminating the product, establish general cleaning and sanitizing procedures throughout the operation, and monitor bioburden levels on raw materials and equipment.

8 Product claims

Condoms meeting the requirements of this International Standard may be used for contraceptive purposes and to help protect against sexually transmitted infections. Manufacturers shall justify any additional claims made for their products. If a manufacturer makes a claim relating to improved efficacy or safety, then the claim shall be substantiated by appropriate clinical investigation to demonstrate superiority. Information supporting such claims shall be made available on request to interested parties including regulatory authorities and notified bodies.

9 Design

9.1 Integral bead

The open end of the condom shall terminate in an integral bead.

9.2 Lubrication

If verification is required of the quantity of lubricant on a condom (and in the package), either of, the methods given in [Annex C](#) shall be used. The criteria of compliance shall be as agreed between the parties concerned.

The methods in [Annex C](#) also recover part of the dressing powder on the condom. An allowance should be made for this when manufacturers or purchasers specify lubricant levels.

9.3 Dimensions

9.3.1 Length

When tested by the method given in [Annex D](#), taking 13 condoms from each lot, no individual measurement shall be below 160 mm.

Condoms that do not comply with the limit specified above cannot be claimed to meet ISO 4074.

9.3.2 Width

When tested by the method given in [Annex E](#), measuring at the narrowest part of the condom in the range of 20 mm to 50 mm from the open end, taking 13 condoms from each lot, no measurement of the width shall deviate from the nominal width stated by the manufacturer by more than ± 2 mm.

9.3.3 Thickness

If verification is required of the thickness of a condom, the average thickness, determined in accordance with one of the methods given in [Annex E](#), shall be equal to the claimed nominal thickness, subject to a tolerance of

- $\pm 0,008$ mm for condoms with nominal claimed thickness less than 0,05 mm;
- $\pm 0,01$ mm for condoms with nominal claimed thickness equal to or greater than 0,05 mm.

10 Bursting volume and pressure

When determined in accordance with [Annex H](#), the bursting pressure shall not be less than 1,0 kPa and the bursting volume shall be not less than the following:

- 16,0 dm³ for condoms with a mid-body width greater than or equal to 45,0 mm and less than 50,0 mm; or
- 18,0 dm³ for condoms with a mid-body width greater than or equal to 50,0 mm and less than 56,0 mm; or
- 22,0 dm³ for condoms with a mid-body width greater than or equal to 56,0 mm and less than 65,0 mm; or
- 28,0 dm³ for condoms with a mid-body width greater than or equal to 65,0 mm and not more than 75,0 mm.

For the purpose of this test, the mid-body width is the mean flat width rounded to the nearest 0,5 mm of 13 condoms measured in accordance with [Annex E](#) at a point (75 ± 5) mm from the closed end excluding the reservoir tip.

The compliance level for each lot shall be an AQL of 1,5 for condoms that fail the requirement for bursting volume or bursting pressure or both.

Condoms that do not comply with the limits specified above cannot be claimed to meet ISO 4074.

For condoms that have a mid-body width less than 45,0 mm and/or are shorter than 160 mm excluding the reservoir tip, guidelines for bursting pressures and volumes are given in [Annex P](#). Marketing of these products is at the discretion of the appropriate regulatory authorities or notified bodies.

11 Stability and shelf life

11.1 General

Manufacturers shall verify that the condoms comply with the requirements of [Clauses 10, 12, and 14](#) until the end of the labelled shelf life. Products on the market at the time of publication of this International Standard whose shelf lives have been established according to the procedures specified in ISO 4074:2002 shall be deemed to comply with the shelf life claims of this International Standard unless the manufacturer has made significant changes to the process, formulation, or packaging type. Shelf life claims shall not exceed 5 years from the date of manufacture.

The date of manufacture can be the date of dipping or the date of packaging in individual sealed containers, depending upon the procedures specified by the manufacturer. The date of manufacture shall not exceed 2 years from the date of dipping. Unpackaged condoms shall be stored under controlled conditions as specified by the manufacturer between dipping and packaging. Manufacturers shall have documented procedures for validating the storage conditions and maximum storage period. The stored condoms shall be protected from exposure to excessive temperatures, light, ozone, and any other factor that could affect the shelf life of the packaged condoms.

Assessment for minimum stability and shelf life claims shall be verified on condoms that have been stored in bulk for the maximum permitted period between dipping and packaging and under the conditions specified by the manufacturer.

Data supporting the shelf life claims made by the manufacturer shall be made available on request to interested parties including regulatory authorities, notified bodies and testing laboratories.

Before compliance with this International Standard may be claimed for a new or modified condom design, the manufacturer shall provide evidence that the following requirements have been met the following:

- the condom shall comply with the minimum stability requirements as described in [11.2](#);
- a real-time study as described in [11.3](#) to determine shelf life shall have commenced;
- pending completion of the real-time study, manufacturers shall substantiate shelf-life claims as described in [11.4](#).

NOTE 1 A modified condom design is one in which there have been significant changes to the formulation, manufacturing process, or individual sealed containers.

NOTE 2 Compliance with the requirements of [11.2](#) does not imply that the shelf life of the product has been determined.

NOTE 3 A practical limit of 5 years has been set for the shelf life because manufacturers have no control over storage conditions once condoms have been distributed.

Shelf life estimates ([11.4](#)) shall be based on a mean kinetic temperature of $(30_{-2}^{+5})^{\circ}\text{C}$ for all climatic conditions and should be carried out on condoms from the same production lots as used for real-time determination of shelf life ([11.3](#)).

11.2 Minimum stability requirements

Test three lots of condoms for conformity with this International Standard, except for [15.2](#) and [15.3](#).

Only lots meeting all of the requirements of [Clauses 9, 10, 12, 13, and 14](#) shall be used for this test.

Condition samples in their individual sealed containers according to [Annex I](#), one set for (168 ± 2) h (1 week) at $(70 \pm 2)^{\circ}\text{C}$ and the other set for (90 ± 1) days at $(50 \pm 2)^{\circ}\text{C}$. At the end of the incubation periods, withdraw the condoms and test for compliance with the requirements of [Clauses 10, 12, and 14](#) using as a minimum the sampling plans specified in [Annex A](#) or preferably the sampling plans in [Annex B](#).

This test ensures that the condoms have adequate stability to be placed on the market pending verification of shelf life claims. It is not predictive of shelf life. Purchasers, test laboratories, regulatory authorities, and other interested parties may confirm that condoms meet the minimum stability requirements by testing condom lots for compliance with the requirements of [Clause 10](#) after oven conditioning for (168 ± 2) h (1 week) at (70 ± 2) °C. When such testing is carried out, it might be appropriate to use reduced inspection levels.

The test report shall include the relevant requirements of [Annexes H, K, M and N](#), and [Clause 16](#).

NOTE Data to verify compliance with [11.2](#) can be extracted from studies for estimates of shelf life ([11.4](#)).

11.3 Procedure for determining shelf life by real-time stability studies

Real-time stability testing shall be conducted on three lots of condoms meeting all of the requirements of [Clauses 9, 10, 12, 13](#), and [14](#). Real-time stability studies shall continue for the full period of the shelf life claim. In no case shall shelf life claim exceed 5 years.

For condoms placed on the market based upon accelerated stability studies, if the real-time data indicates a shorter shelf life than that claimed on the basis of accelerated ageing ([11.4](#)), the manufacturer shall notify the relevant regulatory authorities and direct purchasers. The manufacturer shall change the shelf life claim for the product to one based upon the real-time study.

Test three lots of condoms for conformity with this International Standard, except for [15.2](#) and [15.3](#).

After testing according to [Annex K](#) using the sampling plans specified in [Annex A](#) or preferably the sampling plans in [Annex B](#), the condoms shall meet the requirements specified in [Clauses 10, 12](#), and [14](#).

The test report shall include the requirements of [Annexes H, K, M and N](#), and [Clause 16](#).

11.4 Estimating shelf life based upon accelerated stability studies

Pending the completion of real-time studies, manufacturers shall substantiate provisional shelf life claims. Accelerated stability studies may be used for this purpose.

Test three lots of condoms for conformity with this International Standard, except for [15.2](#) and [15.3](#).

Only lots meeting all of the requirements of [Clauses 9, 10, 12, 13](#), and [14](#) shall be used for accelerated stability testing.

Further information on accelerated studies is provided in [Annex L](#). Data generated from such studies shall support the claim that the condoms fulfil the requirements in [Clauses 10, 12](#), and [14](#) for the duration of the labelled shelf life at (30^{+5}_{-2}) °C.

The test report shall include the requirements of [Annexes H, L, M and N](#), and [Clause 16](#).

12 Freedom from holes

When tested by either method described in [Annex M](#), the compliance level, for each lot, for the sum of condoms with visible and non-visible holes and tears shall be an AQL of 0,25.

The method for testing for freedom from holes specified in ASTM D3492 may also be used.

Condoms that have a mid-body width less than 45 mm and/or are shorter than 160 mm excluding the reservoir tip cannot be claimed to meet ISO 4074. Guidelines for the volume of water or electrolyte to be used in the freedom from holes test for these condoms are given in [Annex P](#). Marketing of these products is at the discretion of the appropriate regulatory authorities or notified bodies.

13 Visible defects

For visible defects specified in [M.2.3.4](#) and [M.3.3.5](#), the compliance level for each lot shall be an AQL of 0,4.

14 Package integrity of individual container

When individual containers comprising one or more flexible laminated films sealed together are tested in accordance with [Annex N](#), the compliance level for each lot shall be an AQL of 2,5.

When condoms are tested for freedom from holes, the individual containers shall be inspected for visibly open seals. The compliance level for individual containers having visibly open seals shall be an AQL of 0,4.

For designs of individual container other than flexible laminated films, the manufacturer shall apply a suitable pack integrity test. The compliance level for each test shall be an AQL of 2,5. The method given in [Annex N](#) may be used with suitable adjustment to the level of vacuum applied. Details of the test method shall be provided to regulatory authorities, testing laboratories, and purchasers on request.

15 Packaging and labelling

15.1 Packaging

Each condom shall be packed in an individual container. One or more individual containers may be packed in other packaging such as a consumer package. The individual container, or consumer package or both, shall be opaque to light. If condoms are intended to be supplied only in individual containers, the individual containers shall be opaque.

If a marking medium, such as ink, is used on a condom or on any part of a package directly in contact with a condom, it shall not have any deleterious effect on the condom or be harmful to the user.

Individual containers and any other packaging shall protect the condom from damage or loss of lubricant during normal transport and storage.

Individual containers and any other packaging shall be designed in such a way that the package can be opened without damaging the condom. The design of the individual container should facilitate easy opening, for example by having a notch to help initiate tearing.

15.2 Labelling

15.2.1 General

Where national regulations apply in relation to labelling, they take precedence over the requirements in this International Standard. When there is no contradiction with national regulations, the requirements of this International Standard shall apply.

15.2.2 Symbols

If symbols are used on packaging, information, and marketing materials, the symbols shall meet the requirements in ISO 15223 (all parts). If symbols are used on the outside of the consumer packaging, their meaning should be explained in the additional information on the inside of the consumer package or a leaflet contained within the consumer package.

15.2.3 Individual container

Each individual container shall be indelibly and legibly marked with, at least, the following information.

- a) The identity of the manufacturer or distributor or, if permitted by local regulations, the registered brand or trade mark.

- b) The manufacturer's identifying reference for traceability (e.g. the lot number).
- c) The expiry date (year and month). The format of the year shall be in four digits; the format of the month shall be in letters or two digits.
- d) Any additional marking required by local regulations.

NOTE For condoms intended for distribution within the European Union, additional marking includes the CE Mark. Refer to EN 1041[Z] for additional requirements for condoms intended for distribution within the European Union.

15.2.4 Consumer package

15.2.4.1 General

The outside of the consumer package shall bear at least the following information in at least one of the official language(s) of the country of destination or as stipulated by the national authority.

- a) A full description of the condom, for example whether or not it has a reservoir tip, is parallel sided or shaped, is coloured or natural, textured or plain, has a flavour or fragrance, and is lubricated or not. A diagram may be used to convey some of this information.
- b) The number of condoms contained.
- c) The nominal width of the condom.
- d) The nominal length of the condom if this is shorter than 160 mm (see [P.1](#) for rationale).
- e) The name or trade name and full postal address of the manufacturer and/or distributor and/or manufacturer's authorized representative, depending on national and regional requirements. A PO Box number is not an acceptable address.

NOTE For condoms intended for distribution within the European Union, the name or trade name and address of the manufacturer is required. Where the manufacturer does not have a registered place of business in the European Union, the name and address of the European Authorized Representative is also required.

- f) The expiry date (year and month). The format of the year shall be in four digits and the format of the month shall be in letters or two digits. If a consumer package includes condoms from different lots, the earliest expiry date shall apply to all condoms.
- g) A statement to store the condom in a cool dry place away from direct sunlight. Accepted symbols may be used as an alternative.
- h) If the individual containers are not opaque to light a statement that individual containers should not be stored outside the opaque consumer package.
- i) Whether the condom is lubricated or dry. When a medicinal ingredient is added, it shall be identified and its purpose indicated (e.g. spermicidal). If the condom or lubricant is fragranced or flavoured, this shall be stated.
- j) The manufacturer's identifying reference for traceability (e.g. the identification number/lot number). If different types of condoms, e.g. different colours, are packaged together in the same consumer package, the identification number on the consumer package shall allow the manufacturer to identify uniquely the lot numbers of the individual condoms contained in that package, so that it is possible to trace those lots through all stages of manufacture up to packaging.
- k) A statement that the condom is made of natural rubber latex, which might cause allergic reactions including anaphylactic shock if the user is allergic to latex. An accepted symbol for natural rubber latex may be used as an alternative. If a symbol is used the additional information on the inside of the consumer package or a leaflet contained within the consumer packaging shall include a statement warning about the risk of allergic reactions including anaphylactic shock if the user is allergic to latex.

- l) For condoms intended for distribution within the European Union, the CE Mark.
- m) A statement that the condom is for single use only. An accepted symbol may be used as an alternative.
- n) A statement to read the instructions for use. An accepted symbol may be used as an alternative.

If the condom thickness is stated on the product labelling, the nominal thickness shall be based on measurements made using the test method described in [Annex E](#).

15.2.4.2 Additional information

The outside or the inside of the consumer package, or a leaflet contained within the consumer package, shall bear at least the following information expressed in simple terms, and in at least one of the official language(s) of the country of destination, if possible supplemented by pictorial representations of the major steps involved or as stipulated differently by that country.

- a) Instructions for use of the condom, including
 - 1) the need to handle the condom carefully, including removal from the package so as to avoid damage to the condom by fingernails, jewellery, etc.,
 - 2) how and when to put on the condom; mention should be made that the condom should be placed on the erect penis before any contact occurs between the penis and the partner's body to assist in the prevention of sexually transmitted infections and pregnancy,
 - 3) the need to stop and check if the user feels the condom slipping off or tightening excessively onto the penis because this might lead to breakage,
 - 4) the need to withdraw the penis soon after ejaculation, while holding the condom firmly in place at the base of the penis,
 - 5) the need, if an additional lubricant is desired, to use the correct type of lubricant which is recommended for use with condoms and the need to avoid the use of oil-based lubricants, such as petroleum jelly, baby oil, body lotions, massage oils, butter, margarine, etc., as these are deleterious to the integrity of the condom,
 - 6) the need to consult a doctor or pharmacist about the compatibility of topical medicines that might come in contact with the condom,
 - 7) advice to seek medical assistance as soon as possible, at least within 72 h should a condom leak or burst during use,
 - 8) advice that if the individual container is obviously damaged to discard that condom and use a new one from an undamaged package.
- b) Instructions on how to dispose of the used condom.
- c) A statement that the condom is for single use and that if reused there might be an increased risk of failure or infection.
- d) An explanation of any symbol used on the packaging.
- e) A statement that the condom is made of natural rubber latex, which might cause allergic reactions including anaphylactic shock if a symbol for latex is used on the packaging.
- f) The date of issue or the date of latest revision of the instructions for use.
- g) The number of this International Standard, i.e. ISO 4074.
- h) For condoms intended for distribution within the European Union, the CE Mark.

15.2.5 Condoms not distributed in consumer packages

For condoms that are distributed without a consumer package (e.g. in single foils or strips of foils), complete information should be made available in accordance with local regulations.

NOTE 1 In the European Union the labelling must comply with the European Medical Device Directives 93/42/EEC as amended.

NOTE 2 In countries outside of Europe, information can be in the form of leaflets, training sessions, posters, or additional packing added in the distribution chain, subject to local regulations. For guidance on the content, see [15.2.4.1](#) and [15.2.4.2](#).

15.3 Inspection

When tested for conformity for labelling requirements, 13 consumer packages and 13 individual containers from each lot shall be inspected. All inspected containers shall conform to the requirements.

Under certain conditions it is permissible for the manufacturer to correct faults associated with packaging and labelling requirements and resubmit the lot for further conformity testing. Examples include insertion of missing instruction leaflets or re-packaging of individual containers into new complete consumer packages before placing on the market.

If condoms from the same lot are packed into different consumer packages, at least one consumer package of each variant should be inspected. The number of packages inspected should not exceed 13 unless the number of variants exceeds 13.

16 Test report

Test reports to demonstrate conformity to one or more of the requirements of this International Standard shall contain at least the following information:

- a) name and address of the test laboratory;
- b) name and address of the client;
- c) identification of the test report;
- d) the identity of the sample (brand or name, sample size, lot number, and lot size);
- e) origin of the sample, date of the sample's arrival at the laboratory;
- f) a reference to this International Standard, i.e. ISO 4074, and the relevant annexes;
- g) a description of all deviations from this International Standard;
- h) the test results according to relevant annexes; summary results may be substituted by agreement with the client but the full results shall be provided on request to relevant interested parties;
- i) the uncertainty in the test result, if available;
- j) date of the test report and the signature and title of the person(s) responsible for the report.

Annex A (normative)

Sampling plans intended for assessing compliance of a continuing series of lots of sufficient number to allow the switching rules to be applied

A.1 Quality verification

When on-going verification is required of the quality of condoms, it is suggested that, instead of concentrating solely on evaluation of the final product, the party concerned also directs his attention to the manufacturer's quality system. In this connection, it should be noted that ISO 9000^[17] series and, in particular, ISO 13485^[4] covers the provision of an integrated quality system.

A.2 Sampling plans and compliance levels

If a party wishes to establish, by inspection and testing of samples of the final product, whether a continuing series of lots are in compliance with the requirements of this International Standard, the sampling plans and acceptance criteria given in [Table A.1](#) shall be applied.

Manufacturers may use the schemes in [Table A.1](#) or may devise and implement validated alternative quality control methods that result in at least equivalent consumer protection.

When tests are being conducted on fewer than five lots of condoms, the additional protection of the switching rules in ISO 2859-1 is not available and it is recommended that the sampling plans given in [Annex B](#) are used to maintain the level of consumer protection.

Table A.1 — Sampling plans and acceptance criteria for a continuing series of lots

Attributes	Inspection level ^a	Acceptance criteria
Length and width	13 condoms	All samples shall meet the criteria of length ≥ 160 mm and width ± 2 mm of stated nominal width
Bursting volume and pressure	General Inspection Level I	AQL of 1,5
Freedom from holes	General Inspection Level I but at least code letter M	AQL of 0,25
Visible defects	General Inspection Level I but at least code letter M	AQL of 0,4
Individual containers with visibly open seals	General Inspection Level I but at least code letter M	AQL of 0,4
Package integrity	Special Inspection Level S-3	AQL of 2,5
Packaging and labelling	13 consumer packages and 13 individual containers	All shall comply
Quantity of lubricant	13 condoms	As agreed (see 9.2)
Thickness	13 condoms	As agreed (see 9.3.3)
^a See ISO 2859-1 where relevant.		

Applications for these sampling plans include the following:

- a) on-going production testing and quality control by a manufacturer;

- b) on-going testing by a purchaser for contractual purposes;
- c) on-going inspection by a national authority.

Annex B (informative)

Sampling plans intended for assessing compliance of isolated lots

Use of the sampling plans given in [Annex A](#) for small numbers of lots, i.e. fewer than five, will result in a higher level of consumer risk because the switching rules are not available. In such circumstances, the use of larger sample sizes is recommended in order to maintain an acceptable level of consumer protection. The choice of a suitable sampling plan will be governed by cost considerations. Larger sample sizes will give better discrimination but at increased cost. Purchasers may, for example, rely upon their experience with a particular supplier when assessing the sample sizes to use for small numbers of lots.

The sampling plans given in [Table B.1](#) when applied to isolated lots provide approximately the same level of consumer protection as those given in [Annex A](#), when used in conjunction with the switching rules. Attention is drawn to the possibility of using double or multiple sampling plans which can reduce the total number of condoms that need to be tested to demonstrate compliance when quality is significantly better than the AQLs.

The producers' and consumers' risk associated with these sampling plans can be obtained by reference to the relevant tables and operating characteristic curves given in ISO 2859-1.

NOTE There is no simple mathematical formula for computing the sample size solely as a function of the lot size. Sample sizes can be increased independently of the lot size to achieve a more reliable estimate of lot quality.

Table B.1 — Sampling plans and acceptance criteria for isolated lots

Attributes	Inspection level ^a	Acceptance criteria
Length and width	13 condoms	All samples shall meet the criteria of length ≥ 160 mm and width ± 2 mm of stated nominal width
Bursting volume and pressure	General Inspection Level I but at least code letter M	AQL of 1,5
Freedom from holes	General Inspection Level I but at least code letter N	AQL of 0,25
Visible defects	General Inspection Level I but at least code letter N	AQL of 0,4
Individual containers with visibly open seals	General Inspection Level I but at least code letter N	AQL of 0,4
Package integrity	Special Inspection Level S-3 but at least code letter H	AQL of 2,5
Packaging and labelling	13 consumer packages and 13 individual containers	All shall comply
Quantity of lubricant	13 condoms	As agreed (see 9.2)
Thickness	13 condoms	As agreed (see 9.3.3)
^a See ISO 2859-1 where relevant.		

These sampling plans should be used for the following:

- a) type testing as part of a certification procedure;
- b) in cases where the total number of lots being assessed is insufficient to allow the switching rules to be effective;

c) in cases of dispute involving isolated lots, e.g. for referee testing.

Annex C (normative)

Determination of total lubricant for condoms in individual containers

C.1 General

This annex specifies two alternative methods of equal validity for determining the amount of lubricant on a condom. The methods differ in the choice of medium used to remove the lubricant. In the first method, propan-2-ol is used. In the second, an aqueous solution of surfactant is used.

If other solvents, surfactants, or surfactant concentrations are used, different results might be obtained. Any changes to the solvent, surfactant, or drying procedures necessary to meet local needs shall be fully validated to demonstrate equivalence with the procedures specified in this International Standard.

C.2 Propan-2-ol method

C.2.1 Principle

The mass loss is determined by removing the lubricant from the pack and condom by washing with a solvent. Washing is carried out either in an ultrasonic bath or by manual agitation. A minimum sample size of 13 condoms shall be used.

C.2.2 Apparatus

C.2.2.1 Ultrasonic cleaning bath(s) or suitable container, e.g. **beaker**, and **stirrer**.

C.2.2.2 Balance, accurate to 1 mg.

C.2.2.3 Propan-2-ol, laboratory reagent grade.

C.2.2.4 Scissors.

C.2.2.5 Indelible marker pen.

C.2.2.6 Soft industrial roll tissue.

C.2.2.7 Drying oven.

C.2.3 Procedure

C.2.3.1 Weigh each sealed individual container to the nearest 1 mg and record the results.

C.2.3.2 Slit the individual container carefully around three edges or tear the containers along one edge. Carefully remove the condom from the individual container, leaving the individual container in one piece. Split the individual container on two sides of the pocket, using scissors if needed. Label each condom and respective individual container using an indelible marker pen, allowing sufficient time for the markings to dry thoroughly.

C.2.3.3 Using a pair of scissors, carefully make a cut across from side to the centre point of the rolled condom. Unroll the condom to a sheet to expose fully all surfaces.

C.2.3.4 When using the ultrasonic bath, immerse the condom and individual container in propan-2-ol in an ultrasonic bath and wash for 2 min to 10 min. Repeat the washing in clean propan-2-ol as many times as necessary until two consecutive weighings differ by less than 10 mg after drying as below in [C.2.3.6](#) to [C.2.3.7](#).

C.2.3.5 When washing the condoms manually, immerse the condom and individual container in propan-2-ol in a bath and wash with manual agitation. Repeat the washing in clean propan-2-ol as many times as necessary until two consecutive weighings differ by less than 10 mg after drying as below in [C.2.3.6](#) to [C.2.3.7](#).

C.2.3.6 Remove the condom and individual container from the propan-2-ol and wipe to remove excess propan-2-ol.

C.2.3.7 Dry the condom and individual container at a temperature not exceeding 55 °C until two consecutive weighings at least 15 min apart differ by less than 10 mg.

C.2.3.8 Weigh each dry condom and individual container to the nearest 1 mg and subtract this result from that found in [C.2.3.1](#) to give the total quantity of lubricant.

C.2.4 Accuracy of lubricant recovery

In an inter-laboratory study, this method was shown to recover about 85 mg more “lubricant” than the amount that was added when the test samples were made. This excess “lubricant” is partly dressing powder, which is also removed by the method.

C.3 Aqueous surfactant method

C.3.1 Principle

The mass loss is determined by removing the lubricant from the individual container and condom by washing with an aqueous surfactant solution. Washing is carried out by manual agitation. A minimum sample size of 13 condoms shall be used.

C.3.2 Apparatus

C.3.2.1 Suitable containers, e.g. **beakers**, and **stirrer**.

C.3.2.2 **Balance**, accurate to 1 mg.

C.3.2.3 **Potassium laurate**, technical grade.

C.3.2.4 **De-ionised water**.

C.3.2.5 **Scissors**.

C.3.2.6 **Indelible marker pen**.

C.3.2.7 **Soft industrial roll tissue**.

C.3.2.8 **Drying oven**.

C.3.3 Procedure

C.3.3.1 Weigh each sealed individual container to the nearest 1 mg and record the results.

C.3.3.2 Slit the individual container carefully around three edges or tear the individual containers along one edge. Carefully remove the condom from the individual container, leaving the individual container in one piece. Split the individual container on two sides of the pocket, using scissors if needed. Label each condom and respective individual container using an indelible marker pen, allowing sufficient time for the markings to dry thoroughly.

C.3.3.3 Using a pair of scissors, carefully make a cut across from side to the centre point of the rolled condom. Unroll the condom to a sheet to expose fully all surfaces.

C.3.3.4 Wipe the condom and individual container with soft industrial roll tissue until the lubricant and oily feel are removed as far as possible.

C.3.3.5 Fill beakers of 250 cm³ capacity with 150 cm³ of wash material (a mass fraction of 5 % potassium laurate dissolved in deionised water, avoiding foaming). Prepare two beakers per condom for a total of two wash cycles per sample.

C.3.3.6 Place each condom (cut and wiped as above) into a separate beaker containing the wash material. Stir the content with a glass rod agitating periodically for 5 min. Next transfer each condom into a second unused beaker containing fresh wash material and repeat the wash cycle procedure for another 5 min. Meanwhile, place the respective individual container into the first wash beaker and wash for 5 min using the same leftover wash material. Next transfer the individual container into respective second wash cycle beaker and repeat wash for another 5 min using the wash material left over after the second condom wash is completed.

C.3.3.7 Check that the pen markings on the individual condoms are still legible. Bulk all 13 condoms together into a large wash container and rinse with 10 dm³ of deionised water. Agitate content with glass rod. Repeat the rinse one more time. If the pen markings are becoming difficult to read (due to fading) wash the condoms individually.

C.3.3.8 Fasten the wet condoms onto drying lines in an oven using pegs (or other devices). Leave the condoms to dry fully in the oven at (55 ± 5) °C until two consecutive weighings differ by less than 10 mg (this should take around 30 min).

C.3.3.9 Check that the pen markings on the individual containers are still legible. Bulk all 13 individual containers together into a large wash container and rinse with 10 l of deionised water. Agitate content with glass rod. Repeat the rinse one more time. If the pen markings are becoming difficult to read (due to fading) wash the individual containers individually. Dry the individual containers in a similar manner to the condoms.

C.3.3.10 Weigh the dried condoms and respective individual containers accordingly to 1 mg and record the results.

C.3.3.11 Subtract the final weight (washed and dried condom and respective individual container) from its original weight (condom in individual container); the difference is measured as the amount of lubricant recovered from a condom.

C.3.4 Accuracy of lubricant recovery

In an inter-laboratory study, this method was shown to be equivalent to a solvent recovery method which recovered about 85 mg more “lubricant” than the amount that was added when the test samples were made. This excess “lubricant” was partly dressing powder, which is also removed by the method.

C.4 Expression of results

Report the amount of lubricant recovered to the nearest 10 mg for each condom and the information specified in [Clause 16](#).

Annex D (normative)

Determination of length

D.1 Principle

The unrolled condom is allowed to hang freely over a mandrel and its length, excluding the reservoir tip, is observed and recorded.

D.2 Apparatus

D.2.1 Mandrel, having a rounded end with a diameter of (25 ± 2) mm with a scale divided into millimetres and dimensions shown in [Figure D.1](#), with the zero beginning at the rounded end or other suitable validated device having the dimensions shown in [Figure D.1](#) capable of measuring the length of the condom from the rounded end.

D.3 Procedure

D.3.1 Move the condom inside the individual container such that it is away from the area where the container is to be torn. Tear the container and remove the condom.

Do not use scissors or other sharp instruments to open the package.

D.3.2 Unroll the condom, stretch it slightly twice but by no more than 20 mm to smooth out the wrinkles caused by the condom having been rolled up. Lubricants may be removed by washing with a suitable solvent such as propan-2-ol and suitable powders may be added to avoid sticking. Alternatively a suitable powder may be used to absorb the lubricant. If a solvent is used to remove the lubricant an adequate period of drying should be allowed before testing.

D.3.3 Put the condom over the mandrel ([D.2.1](#)) and let it hang freely, stretched only by its own mass.

D.3.4 Note to the nearest millimetre the smallest value of the length of the condom that can be read on the scale outside the open end of the condom.

D.3.5 Condoms subjected to this test may also be used for determination of width.

D.4 Expression of results

The test report shall include the information specified in [Clause 16](#) and the length of each tested condom.

Dimensions in millimetres

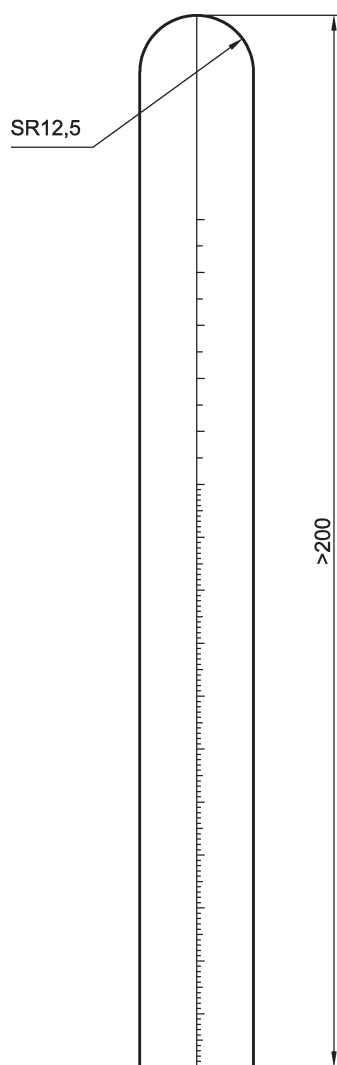

Figure D.1 — Mandrel for determining length of condom

Annex E (normative)

Determination of width

E.1 Principle

The unrolled condom is allowed to hang freely over the edge of a ruler and its width is observed and recorded.

E.2 Apparatus

E.2.1 Ruler, with a scale divided into millimetres or other suitably validated measuring device.

E.3 Procedure

E.3.1 Move the condom inside the individual container such that it is away from the area where the container is to be torn. Tear the container and remove the condom.

Do not use scissors or other sharp instruments to open the package.

E.3.2 Unroll the condom and lay it flat over the edge of the ruler ([E.2.1](#)), perpendicular to the condom's axis, allowing it to hang freely. If a lubricated condom does not hang freely, then the lubricant may be removed by washing with a suitable solvent such as propan-2-ol and suitable powders may be added to avoid sticking. If a solvent is used to remove the lubricant an adequate period of drying should be allowed before testing.

Measure to the nearest 0,5 mm the width of the condom at a point specified in the relevant clauses of this International Standard.

E.3.3 Condoms subjected to this test may also be used for determination of length.

E.4 Expression of results

The test report shall include the information specified in [Clause 16](#) and the width of each tested condom, including the point along the condom at which the measurement was made.

Annex F (normative)

Determination of thickness

F.1 General

This annex describes two test methods for determining the thickness of latex rubber condoms. The mass method is recommended for measuring the thickness of textured condoms when the region specified for thickness measurement is textured. When using the micrometer method the latex film is compressed slightly.

F.2 Mass method

F.2.1 Principle

A condom laid flat and test specimen is die cut from it and weighed. Using the mass, the size of the die-cut specimen, and a density of 0,92 g/cm³, the thickness is calculated.

F.2.2 Apparatus

F.2.2.1 Laboratory scale, accurate to 0,1 mg.

F.2.2.2 Cutting die, in accordance with [J.2.1](#).

F.2.2.3 Hydraulic, pneumatic, or mechanical press, suitable for die cutting.

F.2.2.4 Ruler, graduated in 1 mm.

F.2.2.5 Scissors.

F.2.3 Procedure

F.2.3.1 Move the condom inside the individual container such that it is away from the area where the container is to be torn. Tear the container and remove the condom.

Do not use scissors or other sharp instruments to open the package.

F.2.3.2 Unroll the condom ensuring that it is not excessively stretched in any direction and powder the condom.

F.2.3.3 Lay the condom flat with its length at right angles to the cutting edge of the die. Obtain the test piece by cutting the condom with one stroke of the press when the die is positioned with its centre (30 ± 5) mm from the open end of the condom.

F.2.3.4 Cut the ring open using scissors and measure the length of one edge to the nearest 0,5 mm with the ruler. If the condom is not parallel sided, measure both edges and calculate the mean. Calculate the area as the obtained length, in millimetres, × 20 mm.

F.2.3.5 Repeat [F.2.3.3](#) and [F.2.3.4](#) at (30 ± 5) mm from the closed end and within ± 5 mm of the mid-point between the open and closed ends of the condom excluding the reservoir tip.

F.2.3.6 Wash the samples in propan-2-ol and dry until two consecutive weighings at least 15 min apart differ by less than 1 mg.

F.2.3.7 Weigh the specimen to the nearest 0,1 mg and record the individual values.

F.2.3.8 Calculate the thickness of each specimen as follows:

$$t = \frac{1}{\rho} \times \frac{1}{A} \times m \quad (\text{F.1})$$

where

- t is the thickness of the test specimen, in millimetres;
- ρ is the density of the rubber made from natural rubber latex (see Reference [\[14\]](#)) = 0,92 g/cm³;
- A is the area of the test specimen, in square millimetres;
- m is the mass of the test specimen, in milligrams.

F.3 Micrometer method

F.3.1 Principle

The thickness of the condom is measured directly using a micrometer gauge.

F.3.2 Apparatus

F.3.2.1 A **flat footed micrometer**, dial or digital type, measurement intervals of not larger than 0,001 mm, with a foot pressure set at (22 ± 5) kPa. The recommended foot diameter is between 3 mm and 10 mm.

F.3.2.2 Scissors.

F.3.3 Procedure

F.3.3.1 Move the condom inside the individual container such that it is away from the area where the individual container is to be torn. Tear the individual container and remove the condom.

Do not use scissors or other sharp instruments to open the package.

F.3.3.2 Unroll the condom ensuring that it is not excessively stretched in any direction and wash the condom in propan-2-ol or other suitable solvent to remove lubricants. Dry the condom to a constant mass (± 10 mg). Alternatively, the lubricant may be removed by wiping the condom with soft, absorbent cloth, paper, or tissue moistened with propan-2-ol, or other suitable solvent that does not swell the rubber and left to dry for at least 10 minutes.

F.3.3.3 Cut the condom along its length using scissors and open it out to allow the single wall thickness to be measured.

F.3.3.4 Zero the micrometer, place the test specimen on the micrometer, and take the measurement at ± 5 mm from the mid-point between the open and closed ends of the condom, excluding the reservoir tip. Read and record the single wall thickness from the micrometer to the nearest 0,001 mm. Repeat the measurement at two more locations around the circumference of the condom maintaining the same distance between the open and closed ends of the condom; and then record and average the results.

F.3.3.5 Repeat [F.3.3.4](#) at (30 ± 5) mm from the open end of the condom and at (30 ± 5) mm from the closed end, excluding the reservoir tip.

F.4 Expression of results

The test report shall include the information specified in [Clause 16](#) and the following particulars:

- a) the calculated thickness of each die-cut specimen when using the mass method or the individual thickness measurements and average for each condom when using the micrometer method;
- b) the average thickness at each of the three locations along the length of the condom (i.e. at (30 ± 5) mm from the closed end, (30 ± 5) mm from the open and at ± 5 mm from the midpoint between the open and closed ends);
- c) the average calculated thickness of all the condoms measured.

Annex G (informative)

Determination of microbial contamination

G.1 General

This annex gives three methods for determining microbial contamination (bioburden) on latex condoms. Although these methods have been shown to work effectively with condoms, any methods used need to be validated by the user.

The first method allows the total viable count to be estimated on a condom. The second method also allows the total viable count to be determined but also allows the specified organisms to be identified. The third is based on methods described in the European Pharmacopoeia^[9] for counting the total number of viable, aerobic bacteria on Agar plates (direct plating method).

These methods, which are given as examples, are known to work with condoms. Other methods may be used. Methods for determining microbial contamination on sterile medical devices are given in ISO 11737-1.^[3]

Residual compounding ingredients in condoms can inhibit bacterial growth and interfere with the assays. It is recommended that culture media used contain additives, such as lecithin and polysorbate (Tween 80), that will neutralize these antimicrobial effects. It is essential that the amounts of lecithin and polysorbate (Tween 80) used are validated with any specific condom type to ensure that any residual inhibitory effects from the condom are neutralized without any direct inhibitory action on bacterial growth due to the additives themselves. Methods for validating test methods are given in ISO 11737-1:2006^[3], Annex C. Routine confirmatory testing using spiked samples is strongly recommended, for example using the methods described in USP Microbiological test <62>.^[11] Further information on determining the effectiveness of the culture medium and the validity of the counting method is given in [G.4.3](#).

It is recommended that a preliminary identification of any organisms found is conducted irrespective of the test method used for enumeration. A gram stain, coagulase test, and oxidase test will indicate whether species identification is required. Biochemical profiles may be used to identify organisms to species level.

G.2 Enumeration of total population of aerobic microorganisms on foiled condoms

G.2.1 A random sample of 10 to 13 condoms should be taken from the lot. Each condom is tested individually.

G.2.2 Using sterile forceps and scissors, aseptically remove a condom from the foil, cut the bead in two places, unroll the condom with sterile forceps and place in 10 cm³ of peptone water with added 0,3 % lecithin and 3 % polysorbate (Tween 80). Lecithin and polysorbate are added to neutralize any residual inhibitory effects from the condoms. It is essential that the amount of lecithin and polysorbate (Tween 80) used is validated with any specific condom type to ensure that any residual inhibitory effects from the condom are inhibited without any direct inhibitory action on bacterial growth due to the additives themselves. Lethen broth may be used as an alternative extraction medium.

G.2.3 In order to remove the bioburden from the condom, mix the contents with a shaker, stomacher, or vortex mixer for the time previously determined from validation studies. Care should be taken not to mix too vigorously, as this might kill some microbes.

G.2.4 Using a sterile pipette, transfer 1 cm³ of the extraction fluid into 20 cm³ of molten Sabourauds Dextrose Agar (SDA) kept at 40 °C. Mix gently to disperse the sample throughout the media and pour into a sterile Petri dish. Allow to set.

G.2.5 Repeat with another SDA and with 2 × 20 cm³ of Tryptone Soya Agar (TSA).

G.2.6 Incubate the SDA plates at 20 °C for five days and incubate TSA plates at 30 °C for three days.

G.2.7 Inspect the TSA plates at three days and count colonies. Re-incubate and count at five days.

G.2.8 Count the number of colonies on each TSA plate and find the average of the two counts. Examine the SDA plates and count fungal and yeast colonies. Calculate the average count as above. Make corrections for dilution and recovery factors (previously determined by the validation tests).

The total viable aerobic count is determined by adding together the corrected averages of the fungal and bacterial counts.

G.2.9 Some identification of bacteria is required in order to confirm the absence of the specified organisms. Gram stain and colonial morphology will identify gram positive cocci and gram negative bacilli. A positive coagulase test will indicate probable *Staphylococcus aureus*, while the oxidase test will indicate possible *Pseudomonas* species. Results from these short tests will determine if further identification is required. Biochemical profiling will identify organisms to species level.

G.3 Enumeration of total viable aerobic microbial population and tests for specified microorganisms on foiled condoms

G.3.1 This test is conducted on a pooled sample of 13 condoms. The samples should be taken randomly from a single lot.

G.3.2 Using aseptic technique, remove 13 condoms from packaging with sterile forceps into a large sterile dish, and cut up the condoms using sterile scissors.

G.3.3 Weigh 10 g of material and place it in 100 cm³ of extraction media in either a 150 cm³ bottle or a stomacher bag. The extraction media should be capable of neutralizing any residual antimicrobial effect from the condoms. Suggested media is peptone water with the addition of 3 % polysorbate (Tween 80) and 0,3 % lecithin. The lecithin and polysorbate (Tween 80) are added to neutralize any residual inhibitory effect of the condom; the amounts used need to be validated for any specific condom type to ensure that the any residual inhibitory effects from the condom are neutralized without any direct inhibitory effect due to the additives themselves.

G.3.4 Stomach or mix the sample for the time required to remove the bioburden, as previously determined by validation testing.

G.3.5 Using a sterile pipette, transfer 10 cm³ of the condom extraction fluid into 100 cm³ of soya casein digest broth and gently mix.

G.3.6 Proceed using the methods described in USP 31 Microbiological tests <61> and <62> or in the German Pharmacopoeia (DAB) V2.1.8.1 and V.2.1.8.2^[10] in order to determine total viable count of bacteria and fungi, and absence of *Escherichia coli*, *Staphylococcus aureus*, and *Pseudomonas aeruginosa*.

G.4 Enumeration of the total viable aerobic bacteria and fungi on Agar plates (direct plating method) according to the methods in the European Pharmacopoeia

G.4.1 Preparation of the sample

Unless otherwise prescribed, use 13 sample condoms. Select the condoms at random from the bulk material or from the available containers of the preparation under aseptic conditions. If necessary, to obtain the required quantity, mix the contents of a sufficient number of containers to provide each sample. The condoms should be handled using aseptic procedures and conditions.

Cut the condoms using sterile scissors into small pieces. Take a sample of the cut condoms with a total weight of (10 ± 1) g and shake for (5 to 10) min on a mechanical rocker at approximately 1 000 rpm in 100 cm³ of a suitable medium (e.g. sodium chloride peptone buffer solution [pH 7,0]) with the addition of glass beads. The extraction medium should not have any antimicrobial properties. If necessary, add a suitable surface-active agent such as 1 g/cm³ of polysorbate 80 to assist the suspension of poorly wettable substances. If the condoms are known to have antimicrobial activity, a neutralizing agent may be added to the diluent. Suitable neutralizing materials are polysorbate and lecithin. The types and amounts of neutralizing additives need to be validated. If necessary adjust the pH to about pH 7 and prepare further serial tenfold dilutions using the same diluent.

G.4.2 Examination of the sample

G.4.2.1 Membrane filtration

Use membrane filters having a nominal pore size not greater than 0,45 µm and whose effectiveness to retain bacteria has been established. The type of filter material is chosen in such a way that the bacteria retaining efficiency is not affected by the components of the sample to be investigated. Cellulose nitrate filters, for example, may be used for aqueous, oily and weakly alcoholic solutions and cellulose acetate filters, for example, for strongly alcoholic solutions. The filtration apparatus is designed to allow the transfer of the filter to the culture medium.

Transfer a suitable amount of the sample prepared as described (preferably representing 1 g of the product, or less if large numbers of colony-forming units are expected) to each of two membrane filters and filter immediately. Wash each filter with three quantities, each of about 100 cm³ of a suitable liquid such as buffered sodium chloride-peptone solution pH 7,0. To this solution, surface-active agents such as polysorbate 80, or inactivators of antimicrobial agents may be added. If validated, less than three washes may be applied. Transfer one of the membrane filters, intended primarily for the enumeration of bacteria, to the surface of a suitable agar medium, such as medium B and the other, intended primarily for the enumeration of fungi, to the surface of a suitable agar medium, such as medium C. Incubate the plate of agar medium B at 30 °C to 35 °C, and the plate of agar medium C at 20 °C to 25 °C for five days, unless a reliable count is obtained in a shorter time. Select plates with the highest number less than 100 colonies and calculate the number of colony-forming units per gram or millilitre of product. Place one membrane onto agar medium B for total aerobic microbial count, the other membrane onto agar medium C for the count of fungi. The total viable aerobic count is the sum of the bacterial and fungal counts.

G.4.2.2 Plate-count methods

G.4.2.2.1 Pour-plate method

Using Petri dishes 9 cm in diameter, add to each dish 1 cm³ of the sample prepared as described in [G.4.1](#) and 15 cm³ to 20 cm³ of a liquefied agar medium suitable for the cultivation of bacteria (such as medium B), or 15 cm³ to 20 cm³ of a liquefied agar medium suitable for the cultivation of fungi (such as medium C) at no more than 45 °C. If larger Petri dishes are used, the amount of agar is increased accordingly. Prepare for each medium at least two Petri dishes for each level of dilution. Incubate the plates at 30 °C to 35 °C (20 °C to 25 °C for fungi) for 5 days, unless a reliable count is obtained in a shorter time. Select the plates corresponding to one dilution and showing the highest number of colonies less than 300 (100 colonies for fungi). Take the arithmetic average of the counts and calculate the number of colony-forming units per gram or millilitre.

G.4.2.2.2 Surface-spread method

Using Petri dishes 9 cm in diameter, add 15 cm³ to 20 cm³ of a liquefied agar medium suitable for the cultivation of bacteria (such as medium B) or a liquefied agar medium suitable for the cultivation of fungi (such as medium C) at about 45 °C to each Petri dish and allow to solidify. If larger Petri dishes are used, the volume of the agar is increased accordingly. Dry the plates, for example in a laminar airflow (LAF) bench or in an incubator. Spread a measured volume of not less than 0,1 cm³ of the sample prepared as described in G.4.1 over the surface of the medium. Use at least two Petri dishes for each medium and each level of dilution. For incubation and calculation of the number of colony-forming units proceed as described for the pour-plate method.

G.4.3 Effectiveness of culture media and validity of the counting method

Grow the bacterial test strains separately in containers containing a suitable liquid medium (such as broth medium A) at 30 °C to 35 °C for 18 h to 24 h. Grow the fungal test strains separately on a suitable agar medium (such as medium C without antibiotics) at 20 °C to 25 °C for 48 h for *Candida albicans* and at 20 °C to 25 °C for 7 days for *Aspergillus niger*.

Suitable test strains for assessing the effectiveness of the culture media and validity of the counting method include:

- *Staphylococcus aureus* such as ATCC 6538 (NCIMB 9518, CIP 4.83);
- *Escherichia coli* such as ATCC 8739 (NCIMB 8545, CIP 53.126);
- *Bacillus subtilis* such as ATCC 6633 (NCIMB 8054, CIP 52.62);
- *Candida albicans* such as ATCC 10231 (NCPF 3179, IP 48.72);
- *Aspergillus niger* such as ATCC 16404 (IMI 149007, IP 1431.83).

Use buffered sodium chloride-peptone solution pH 7,0 to make reference suspensions containing about 100 colony-forming units per millilitre. The actual count should be confirmed using a suitable reference method. Any neutralizing agent or other additives used in the condom assay should be included the microorganism suspensions. Use the suspension of each of the microorganisms separately as a control of the counting methods, in the presence and absence of the product to be examined. When testing the membrane filtration method or the plate-count method, a count of any of the test organisms differing by not more than a factor of five from the calculated value from the inoculum is to be obtained. When testing the most-probable-number method, the calculated value from the inoculum is to be within the 95 % confidence limits of the results obtained. To test the sterility of the medium and of the diluent and the aseptic performance of the test, carry out the method using sterile sodium chloride-peptone solution pH 7,0 as the test preparation. There should be no growth of microorganisms.

The solutions and culture media recommended are described in the Chapter 2.6.13 of European Pharmacopeia.^[9]

G.4.4 Interpretation of the results

The bacterial count will be considered to be equal to the average number of colony-forming units found on agar medium B. The fungal count will be considered to be equal to the average number of colony-forming units on agar medium C. The total viable aerobic count is the sum of the bacterial count and the fungal count as described above. If there is evidence that the same types of microorganisms grow on both media this may be corrected. If the count is carried out by the most-probable-number method the calculated value is the bacterial count. Calculate the total viable aerobic count separately for each of the five samples.

G.4.5 Identification

Some identification of bacteria is required in order to confirm the absence of the specified organisms. Gram stain and colonial morphology will identify gram positive cocci and gram negative bacilli. A

positive coagulase test will indicate probable *Staphylococcus aureus*, while the oxidase test will indicate possible *Pseudomonas* species. Results from these short tests will determine if further identification is required. Biochemical profiling will identify organisms to species level.

G.5 Expression of results

The test report should include the information specified in [Clause 16](#) and the results from each test including the total counts, fungal and bacterial counts where these are determined separately, and the identity of any organisms identified by the tests.

Annex H (normative)

Determination of bursting volume and pressure

H.1 Principle

Inflation of a specified length of the condom with air and recording of the volume and pressure required to burst the condom.

Recommendations on system calibration are given in [Annex O](#).

H.2 Apparatus

H.2.1 Inflation apparatus, suitable for inflating the condom with clean, oil-free, and moisture-free air at a specified rate, provided with equipment for measuring volume and pressure and having the following features.

- a) A pressure sensor configured such that there is no pressure differential between the interior of the condom and the pressure sensor.
- b) An apparatus for measuring and recording the volume of air, configured such that the pressure difference between the condoms and the measuring instrument is taken into account when calculating the volume of air in the condom.
- c) Rod or mandrel, of suitable length having a smooth sphere or hemisphere (25 ± 2) mm in diameter at its top for supporting the condom and fixed in a position such that when the condom is clamped the length of the condom excluding the reservoir tip remaining for inflation is (150 ± 3) mm. When testing condoms that are shorter than 160 mm, as described in [Annex P](#), the rod or mandrel should be of such length that the inflation length is as specified in [Annex P](#) with a tolerance of ± 3 mm.
- d) Pressure and volume measuring equipment with expanded uncertainties (using a 95 % confidence interval) of the following:
 - 1) $\pm 3,0$ % for volume at the pass/fail limit;
 - 2) $\pm 0,05$ kPa for pressure.

H.2.2 Clamping device, to hold the condom to permit it to be inflated without leaking and having no sharp edges or protrusions that could damage the condom.

The clamping shall not stretch the condom axially as it is clamped onto the mount. The mount and clamping device shall permit the condom to be mounted and clamped without creasing in the clamped region.

The upper edge of the external clamping mechanism shall have no sharp edges and a radius of not less than 2 mm wherever it is in contact the inflating condom, and shall not extend more than 3 mm beyond the point where the condom is gripped. It shall be possible to mark the point where the condom is gripped, so that the inflation length can be measured, for example by removing the condom and letting it hang on a suitable mandrel as described in [Annex D](#).

H.2.3 Inflation cabinet, having a facility for viewing the condom during inflation, and being of sufficient size to allow the condom to expand freely without touching any part of the cabinet.

H.3 Procedure

H.3.1 Carry out the test under controlled temperature of (25 ± 5) °C.

H.3.2 Move the condom inside the individual container such that it is away from the area where the container is to be torn. Tear the container and remove the condom.

Do not use scissors or other sharp instruments to open the package.

H.3.3 It is recommended that suitable gloves or finger cots be worn while handling the condom. In cases of dispute, gloves shall be worn.

H.3.4 Unroll the condom ensuring that it is not excessively stretched in any direction.

NOTE The condom may be unrolled directly onto the rod on the test equipment.

H.3.5 Hang the condom on the rod [H.2.1 c)] and affix to the mount (H.2.2). Take care when placing the clamping ring on its mount to avoid damaging or stretching the condom. Inflate with air at a rate of $(0,4 \text{ to } 0,5) \text{ dm}^3/\text{s}$ [$(24 \text{ to } 30) \text{ dm}^3/\text{min}$]. Check to ensure that the condom expands and that there are no obvious leaks.

If the condom exhibits an obvious leak, the test should be discontinued because the condom might never burst. The condom should be replaced and the test continued.

NOTE If a statistical summary of bursting data is reported (such as means and standard deviations), data points that appear to come from unnoticed leaks may be excluded from the analysis (e.g. if a bursting volume exceeds twice the median value it can generally be assumed that the condom has leaked, although this is not necessarily true for all types of condoms).

H.3.6 If the condom does not leak, measure and note the bursting volume, in cubic decimetres rounded to the nearest $0,5 \text{ dm}^3$, and the bursting pressure, in kilopascals rounded to the nearest $0,05 \text{ kPa}$.

H.4 Expression of results

The test report shall include the information specified in [Clause 16](#) and the bursting volume and bursting pressure of each tested condom and the temperature at the time of testing in the test laboratory.

Annex I (normative)

Oven treatment for condoms

I.1 General

Oven treatment is used to condition condoms for shelf life determination and for assessing compliance with the minimum stability requirements.

I.2 Apparatus

I.2.1 Oven, capable of maintaining the temperature conditions specified in [Clause 11](#) and [Annexes K](#) and [L](#) of this International Standard. Alternatively conditioning rooms or chambers may be used provided the specified temperature conditions can be maintained.

Manufacturers should ensure that precautions are taken to monitor oven temperatures during the conditioning period and have adequate contingency arrangements in place to respond to any loss of temperature control caused by oven breakdown or loss of power.

I.3 Preparation of condoms for test

Before testing, the condoms shall be conditioned in their original individual packages (i.e. remove the individual container from consumer and/or outer packages before conditioning).

I.4 Procedure

I.4.1 Condition the condoms in an oven at the temperature stipulated in the relevant clause or annex of this International Standard.

Condoms shall be mounted in such a manner as to minimize direct contact of the specimens with the heated surfaces especially the base of the oven, and so ensure even heating of the condoms during oven ageing.

I.4.2 Remove the condoms from the oven after the time stipulated in the relevant clause or annex of this International Standard, and keep the packages at (25 ± 5) °C until tested.

I.4.3 Within 96 h but not sooner than 12 h after removal from the oven, determine bursting volume and pressure according to [Annex H](#), freedom from holes according to [Annex M](#) and package integrity according to [Annex N](#).

I.5 Expression of results

Details of the storage conditions shall be included in the test reports prepared according to [Annexes H](#), [M](#) and [N](#) along with the information specified in [Clause 16](#). Any deviations in the storage conditions such as loss of temperature control or power losses shall be noted.

Annex J (informative)

Determination of force and elongation at break of test pieces of condoms

J.1 General

A test piece is cut from a condom and stretched until it breaks; the force and elongation at break can be measured. There are no requirements for force and elongation at break specified within this International Standard but the test can provide useful information about the latex film and is widely used by manufacturers for process and quality control purposes. For this reason, a description of the test method is included in this International Standard.

J.2 Apparatus

J.2.1 Cutting die, consisting of two parallel knives ($20 \pm 0,1$) mm apart set in a press above a suitable board. The length of the cutting edge of each knife should be not less than 70 mm.

J.2.2 Tensile testing machine, capable of an essentially constant rate of traverse and complying with the following requirements:

- a) capable of equalizing the stress within a specimen either by rotating one roller mechanically at a rotation frequency of approximately 7 min^{-1} or by lubricating the cylindrical surfaces of the rollers with a material that does not affect the latex film. A suitable lubricant is silicone fluid of viscosity $2 \times 10^{-4} \text{ m}^2 \cdot \text{s}^{-1}$ (200 cSt);
- b) capable of determining the breaking load in the range 0 N to 200 N. The maximum permissible value; accuracy $\pm 1 \%$, repeatability 1 %, reversibility 1,5 %, zero $\pm 0,1$ and with a machine resolution of 0,5 %;
- c) having a roller separation speed of $(500 \pm 50) \text{ mm/min}$;
- d) having manual or preferably automatic recording of the separation distance of the rollers and of the load during the test.

Further information on test equipment for rubbers and plastics is given in ISO 5893.^[1]

J.3 Preparation of test specimen

J.3.1 Move the condom inside the package such that it is away from the area where the package is to be torn. Tear the package and remove the condom.

Do not use scissors or other sharp instruments to open the package.

J.3.2 Unroll the condom ensuring that it is not excessively stretched in any direction.

J.3.3 To prevent sticking and allow the cutting of a good test specimen an absorbent powder such as talc may be added to the condom or the lubricant may be removed using a suspension with a mass fraction of 2 % talc in propan-2-ol followed by air drying.

J.3.4 Lay the condom flat with its length at right angles to the cutting edge of the die (J.2.1). Obtain the test piece by cutting the condom with one stroke of the press if possible taking the test piece from a parallel-sided, non-textured region including the portion 80 mm from the open end. If the portion 80 mm from the open end is not parallel-sided or is textured, take the test piece from an adjacent parallel-sided, non-textured region. If no region of the condom is parallel-sided and non-textured, take the test piece from the region 80 mm from the open end.

J.3.5 Lay the test piece flat and put the ruler on top and measure to the nearest 0,5 mm, the distance between the two folded edges.

Each sample should be inspected before testing to make sure that there are no nicks or other edge defects that could give rise to poor results.

J.4 Procedure

J.4.1 Carry out the test under controlled conditions of (25 ± 5) °C. Record the actual temperature of the test to the nearest 0,5 °C.

J.4.2 Place the test piece over the rollers of the tensile testing machine (J.2.2) and stretch it until it breaks.

J.4.3 At break, record the force, to the nearest 0,5 N, and the separation distance between the centres of the rollers to the nearest millimetre.

J.5 Calculation of results

J.5.1 When requested, calculate elongation at break (E) as a percentage for each test piece using Formula (J.1):

$$E = \frac{l_1 + 2d - l_2}{l_2} \times 100 \quad (\text{J.1})$$

where

l_1 is the length of the test piece in millimetres, rounded to the nearest millimetre, in contact with the rollers (equal to 47 mm with rollers of 15 mm diameter);

d is the final distance in millimetres between the centres of the rollers;

l_2 is the original perimeter of the test piece in millimetres (twice the distance obtained in J.3.5).

Round the result to the nearest 10 %.

J.5.2 If it is required to calculate the tensile strength, then the following equations may be used:

When the thickness is determined by the mass method the tensile strength, σ , expressed in megapascals (MPa) is given by Formula (J.2):

$$\sigma = \frac{F_b \rho l}{m} \quad (\text{J.2})$$

where

F_b is the force at break in Newtons;

ρ is the density of rubber (0,92 g/cm³);

l is the distance in millimetres between the two folded edges length of the test piece as determined in [J.3.5](#);

m is the mass in milligrams of the test piece.

When the thickness is determined directly by the micrometer method the tensile strength, σ , expressed in megapascals (MPa) is given by Formula (J.3):

$$\sigma = \frac{F_b}{2wt} \quad (\text{J.3})$$

where

F_b is the force at break in Newtons;

w is the mean width of the test piece in millimetres (20 mm if the die specified in [J.2.1](#) is used);

t is the thickness in millimetres of the condom.

Round the result to the nearest 0,1 MPa.

J.6 Expression of results

The test report shall include the information specified in [Clause 16](#) and the force at break, elongation at break and, if requested, the tensile strength of each tested condom and the temperature at the time of testing in the test laboratory.

Annex K (normative)

Determination of shelf life by real-time stability studies

K.1 Principle

Packaged condoms complying with the requirements of [Clauses 9, 10, 12, 13](#), and [14](#) are conditioned at (30^{+5}_{-2}) °C for the intended shelf life period and then tested for conformity with the requirements of [Clauses 10, 12](#), and [14](#). Samples are tested periodically for bursting properties to monitor changes during the ageing period.

For the purposes of this International Standard, conditioning at (30^{+5}_{-2}) °C has been selected to accommodate storage conditions worldwide.

The procedures described in this annex apply to stability studies on new or modified condoms, or following significant changes to the manufacturing process, formulation, or packaging type. Manufacturers conducting ongoing stability studies on products with established shelf lives, for example as part of a quality management programme, may vary the procedures.

K.2 Procedure

NOTE The total number of samples required to complete a real-time stability study to determine shelf life includes the following:

- a) the number of condoms required to confirm conformity with the requirements of [Clauses 9, 10, 12, 13](#), and [14](#) according to [K.2.1](#);
- b) the number of condoms required to confirm compliance with [Clauses 10, 12](#), and [14](#) at the end of the study, plus any intermediate or repeat testing required, in accordance with [K.2.2](#) and [K.2.3](#);
- c) the number of samples required for the monitoring tests during the shelf life period as described in [K.2.4](#).

It is recommended that additional condoms are also included in case it is necessary to repeat any testing.

K.2.1 Test three lots of condoms packed in their respective individual containers for conformity with the requirements of [Clauses 9, 10, 12, 13](#), and [14](#). It is recommended that the sampling plans in [Annex B](#) are used but as a minimum the sampling plans in [Annex A](#) shall be used.

K.2.2 Condition sufficient condoms from the same lots tested according to [K.2.1](#) in an oven at (30^{+5}_{-2}) °C according to [Annex I](#) or in a controlled environment at (30^{+5}_{-2}) °C to allow testing for compliance with [Clauses 10, 12](#), and [14](#) at the end of the ageing period. It is recommended that the sampling plans in [Annex B](#) are used but as a minimum the sampling plans in [Annex A](#) shall be used.

Manufacturers should ensure that precautions are taken to monitor temperatures during the conditioning period and have adequate contingency arrangements in place to respond to any loss of temperature control caused by equipment breakdown or loss of power.

It is strongly recommended that additional condoms be conditioned as spares in case there is a need for any re-testing. The number of additional condoms should be sufficient to allow testing for compliance with [Clauses 10, 12](#), and [14](#) at an intermediate stage during the stability study according to [K.2.3](#).

K.2.3 At the end of the proposed shelf life period or earlier if indicated by the monitoring tests specified in [K.2.4](#), test the condoms for compliance with [Clauses 10, 12](#), and [14](#) using preferably the sampling plans in [Annex B](#) but as a minimum the sampling plans in [Annex A](#).

K.2.4 During the ageing period, manufacturers shall monitor the progress of the stability study. This is to provide an early warning should the shelf life prove to be shorter than the provisional shelf life estimated from the accelerated stability studies. Based on practical experience, it has been found that determining airburst properties periodically according to [Annex H](#) provides the best method of monitoring stability. Manufacturers may opt to use one of the following two methods:

- a) Condition sufficient additional samples according to [K.2.2](#) to allow at least 125 condoms to be tested for airburst properties according to [Annex H](#) at intervals of one year or less. At each time interval, remove at least 125 condoms from the oven or controlled environment and determine bursting volume and pressure according to [Annex H](#). Assess compliance with [Clause 10](#) using the appropriate acceptance number from ISO 2589-1 for the sample size used. Record the number of non-compliers and the mean and standard deviation for the burst properties. Continue the study if not more than one set of samples has failed at any time point. If at any time during the study a second set of samples fails to meet the requirements of [Clause 10](#), test the predetermined number of samples for compliance with [Clauses 10, 12](#), and [14](#) according to [K.2.3](#).

NOTE With a sample size of 125 condoms, the probability of all three lots complying with the AQL of 1,5 specified in [Clause 10](#) is greater than 96 % if the average percentage of nonconforming condoms is less than 1,5 %. If the percentage of nonconforming condoms is greater than 3 % then the probability of all three lots complying with the AQL of 1,5 will be less than 57 %.

- b) Condition sufficient additional samples according to [K.2.2](#) to allow at least 32 to be tested for airburst properties according to [Annex H](#) at intervals of one year or less. At each time interval remove 32 condoms from the oven or controlled environment and determine bursting volume and pressure according to [Annex H](#). If the mean and standard deviation (or 95 % confidence intervals) of the bursting properties at any time deteriorate to the point where the condoms might be approaching the limit of complying with the air bursting requirements of [Clause 10](#) then test the predetermined number samples for compliance with [Clauses 10, 12](#), and [14](#) according to [K.2.3](#).

NOTE The study can be monitored, for example, by plotting the mean and standard deviation (or 95 % confidence intervals) of the bursting pressures and volumes against time for each lot. If the airburst results are normally distributed then the condoms can be considered to be at the limit of compliance with the AQL specified in [Clause 10](#) when the difference between the mean burst pressure or volume and specified minimum burst volume or pressure is 2,17 standard deviations. In practice, airburst results are generally skewed to lower values; failure to comply with the AQL specified in [Clause 10](#) can occur when the differences between the mean and the minimum specified values are greater than 2,17 standard deviations. Manufacturers should consider completing testing according to [K.2.3](#) once the differences between the mean and the specified values drop below 3 standard deviations and definitely if the differences drop to 2,17 standard deviations or less.

K.3 Confirmation of shelf life claim

The shelf life shall be up to that period, not to exceed 5 years, during which the condoms comply with the requirements of [Clauses 10, 12](#), and [14](#) when tested according to [K.2.3](#). Any decision about whether the condoms comply with the requirements of [Clauses 10, 12](#), and [14](#) shall be made on the basis of test results for the predetermined samples sizes specified in [K.2.3](#) and not on the monitoring tests according to [K.2.4](#).

If the confirmed shelf life is less than the labelled shelf life, adjust the shelf life claim and notify the regulatory authorities and direct purchasers.

K.4 Test report

The test report shall include the requirements of [Annex H](#) in the form specified by [Clause 16](#) and the following:

- a) number of nonconforming condoms with respect to [Clauses 10](#), [12](#), and [14](#) as determined according to [K.2.3](#);
- b) the confirmed shelf life and either of the following:
 - 1) intermediate results for airburst properties as determined according to [K.2.4 a\)](#) including the number of nonconforming condoms with respect to [Clause 10](#);
 - 2) plots of the means and standard deviations or 95 % confidence intervals of the bursting pressure and volume against time as specified in [K.2.4 b\)](#).

Interim test reports shall be made available to appropriate regulatory bodies on request, to document that the real-time study has begun and that intermediate results are satisfactory.

Annex L (informative)

Guidance on conducting and analysing accelerated ageing studies

L.1 General

Accelerated ageing studies should be used to support provisional shelf life claims pending completion of real-time studies. This annex describes general procedures that may be used for conducting accelerated ageing studies to estimate a provisional shelf life for market introduction while real-time studies are in progress.

Accelerated studies should be completed on packaged condoms complying with the requirements of [Clauses 9, 10, 12, 13, and 14](#).

If a manufacturer has determined the shelf life of an existing product through real-time stability studies and has established a set of accelerated ageing conditions that can be used to verify the shelf life of this product, then the procedure described in [L.3](#) may be used to establish a provisional shelf life for a new or modified condom. Otherwise an accelerated stability study should be conducted using the conditions specified in [L.2](#).

Manufacturers conducting ongoing stability studies on products with established shelf lives, for example as part of a quality management programme, may vary the procedures.

L.2 Procedure for determining a provisional shelf life in the absence of a control condom with real-time stability data

This method should be used in the absence of real-time stability data for an appropriate control condom.

Condition samples of condoms from three production lots in ovens or a controlled environment at (50 ± 2) °C. It is recommended that sampling is in accordance with [Annex B](#) but as a minimum the sampling plans in [Annex A](#) shall be used. Manufacturers should ensure that precautions are taken to monitor temperatures during the conditioning period and have adequate contingency arrangements in place to respond to any loss of temperature control caused by equipment breakdown or loss of power.

Remove the condoms from the ovens or controlled environment and assess compliance with the requirements in [Clauses 10, 12, and 14](#). If all lots are in compliance, then the appropriate provisional shelf life may be assigned to the product depending on the conditioning period:

- a shelf life of 2 years after a period of 90 days;
- a shelf life of 3 years after a period of 120 days;
- a shelf life of 5 years after a period of 180 days.

L.3 Procedure for determining a set of ageing conditions using a control condom with real-time stability data

L.3.1 This procedure can only be used when a control condom is available for which the shelf life has been determined by a real-time study.

L.3.2 Condition condoms from a minimum of two production lots of control condoms and three production lots of the new or modified condoms in ovens at selected temperatures in accordance with [Annex I](#). It is recommended that a minimum of two temperatures is used.

At appropriate time intervals, remove samples of condoms from the ovens or controlled environments and determine the air bursting properties according to [Annex H](#). A minimum of five time points at the selected temperature(s) is recommended. It is recommended that at least 32 condoms be tested at each time/temperature point.

Compare the changes in bursting properties of the control and test condoms at different time points and temperatures. Based on this comparison establish an equivalent set of ageing conditions for the new condom that can be used to assess the provisional shelf life of the product. The temperatures and ageing times should be sufficient to ensure that a significant change in the air bursting properties of the control condoms occurs.

NOTE Once a set of accelerated ageing conditions has been established for a specific control condom, these conditions may be used for subsequent stability studies without repeating this stage of the study.

L.3.3 Having determined a suitable set of ageing conditions take samples of condoms from three production lots and condition the samples according to [Annex I](#) using the selected ageing conditions. It is recommended that sampling is in accordance with [Annex B](#) but at least [Annex A](#) should be used. Manufacturers should ensure that precautions are taken to monitor temperatures during the conditioning period and have adequate contingency arrangements in place to respond to any loss of temperature control caused by equipment breakdown or loss of power.

Remove the condoms from the ovens or controlled environment and assess compliance with the requirements in [Clauses 10, 12, and 14](#). If all lots are in compliance then the appropriate provisional shelf life may be assigned to the product.

For convenience, the ageing temperatures can be selected as 70 °C and 50 °C and, provided the ageing periods at these temperatures equal or exceed 7 days at 70 °C and 90 days at 50 °C, then this test may also be used to verify the requirements of [11.2](#).

L.4 Test report

The test report shall include the requirements of [Annex H](#) in the form specified by [Clause 16](#) and the following:

- a) a description of the procedure used ([L.2](#) or [L.3](#));
- b) the ageing period used at (50 ± 2) °C (procedure [L.2](#));
- c) a summary of all the data used to justify the selected accelerated ageing conditions (procedure [L.3](#));
- d) details of the selected accelerated ageing conditions (procedure [L.3](#));
- e) the estimated provisional shelf life claim.

Annex M (normative)

Testing for holes

M.1 General

This annex specifies two of the alternative methods for testing natural rubber latex condoms for holes: the water leak test and the electrical test.

M.2 Water leak test

M.2.1 Principle

Filling of the condom with a specified volume of water and examining for visible water leakage through the wall of the suspended condom. In the absence of any leakage, the condom is then rolled on coloured absorbent paper, which is subsequently examined for signs of leakage of water from the condom.

M.2.2 Apparatus

M.2.2.1 Mounting equipment, suitable for mounting the condom at its open end, allowing it to be freely suspended, with a means of filling the condom with water while it is suspended. An example of a suitable mount is shown in [Figure M.1](#). Optionally, a rubber ring may be used to retain the condom on the mount.

M.2.2.2 Coloured absorbent paper.

M.2.2.3 Rolling device (optional), incorporating a smooth transparent plate. The device may be placed at a fixed height of (30 ± 5) mm above and parallel to the paper, whose horizontal movement rolls the condom back and forth.

The plate, if used, shall turn the condom through at least one complete revolution, when it is moved through its travel.

M.2.2.4 Clamping device (optional), suitable for holding the twisted open end of a condom and preventing it from leaking, without causing damage to the part to be rolled on absorbent paper. An example is a sprung paper clip.

M.2.3 Procedure

M.2.3.1 Inspect the individual containers and record any that have visibly open seals.

M.2.3.2 Move the condom inside the individual container such that it is away from the area where the container is to be torn. Tear the container and remove the condom.

Do not use scissors or other sharp instruments to open the package. Wear suitable gloves or finger cots while handling the condom.

M.2.3.3 Unroll the condom ensuring that it is not excessively stretched in any direction. If any hole or tear is noticed, that condom shall be deemed non-compliant and further testing of that condom shall be discontinued.

M.2.3.4 Record condoms with visible defects (see [3.15](#)) other than holes and tears.

M.2.3.5 Fit the open end of the condom onto the mount so that the condom is suspended open end upwards.

M.2.3.6 Add the volume of water specified in [Table M.1](#) within a tolerance of ± 10 cm³ at a temperature between 10 °C and 40 °C to the condom. Make sure that the humidity in the ambient air does not condense on the outside of the condom. Inspect the condom for visible signs of leakage. Deem any condom exhibiting visible signs of leakage more than 25 mm (determined to an accuracy of ± 1 mm) from the open end a non-complier and discontinue the test. Holes found near the open end shall be marked, and measured after the condom is emptied to determine whether they are more than 25 mm from the open end.

Table M.1 — Fill volumes for conducting the water leakage test

Condom length mm	Water volume cm ³			
	Mid-body condom width mm			
	45 to 49,5	50 to 55,5	56 to 65	65,5 to 75
160 to 185	300	300	350	475
186 to 210	300	300	400	525
211 to 240	300	350	450	600

For the purpose of this test, the mid-body width is the mean flat width rounded to the nearest 0,5 mm of 13 condoms measured in accordance with [Annex E](#) at a point (75 ± 5) mm from the closed end excluding the reservoir tip. The length of the condom is determined according to [Annex D](#).

If, because of lack of distension of the condom, it is not possible for the specified volume of water to be contained within the condom, permit the remainder of the water to form a pressure head within the filling system.

Then carry out the rolling procedure described in [M.2.4](#).

M.2.4 Rolling procedure

M.2.4.1 If there is no visible leakage through the condom after suspension, take hold of the condom by the closed end, and, if necessary, gently stretch the condom to displace the water from the open end. Seal the condom by twisting it less than 25 mm from the open end, for approximately 1,5 revolutions, and remove it from the mount. Hold the end closed with one hand, or with a suitable clamping device ([M.2.2.4](#)). Wipe off any water on the outside on the condom with a soft absorbent cloth or paper.

M.2.4.2 Transfer the condom onto a dry sheet of absorbent paper and lay it down with the axis of the cylinder thus formed parallel to the paper.

a) Manual rolling

Using the free hand, roll the condom on the paper through at least two complete revolutions. During rolling, spread the fingers of the hand so as to distribute the force on the condom as equally as possible. Maintain the hand at a distance of 25 mm to 35 mm above the absorbent paper. Move the hand with respect to the condom so that the condom as a whole is subjected to hand pressure and comes in contact with the absorbent paper.

b) Mechanically assisted rolling

Using the rolling device in [M.2.2.3](#), roll the condom through at least two complete revolutions on the paper.

The condom may be rolled through more than one revolution in order to verify whether or not there is leakage present. It is intended that the number of revolutions be small, and in no case greater than 10 over both pieces of absorbent paper.

Inspect the paper for any sign of leakage of water from the condom. Ignore any marks made by the lubricant. Holes found near the open end shall be marked, and the condoms measured after being emptied to verify that they are more than 25 mm from the open end. Condoms with holes more than 25 mm from the open end shall be counted as non-compliant.

M.2.4.3 Hang the filled condom vertically from one hand and, with the other hand, squeeze the condom to ensure that most of the water is forced into the lower half. Avoid excessive localized stretching. Firmly press the closed end of the condom onto the absorbent paper and move the hands carefully in a circle twice so that the lower half of the water filled section contacts the absorbent paper while avoiding sliding and abrasion of the condom on the paper. Inspect the paper for any sign of leakage of water from the condom. Ignore any marks made by the lubricant. Condoms with holes more than 25 mm from the open end shall be counted as non-compliant.

NOTE 1 Steps M.2.4.2 and M.2.4.3 may be conducted in any order. For lubricated condoms, the rolling may be done twice on two separate sheets of absorbent paper, to eliminate confusion between marks made by the lubricant and those made by the water.

NOTE 2 Rolling forward by one complete revolution and then back by one complete revolution counts as two complete revolutions.

Dimensions in millimetres

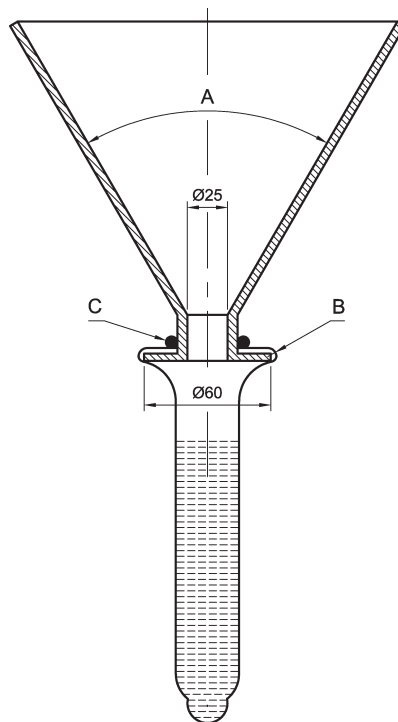

Key

- A $60^{\circ} \pm 10^{\circ}$
- B well-rounded edge
- C rubber ring

Figure M.1 — Example of a suitable mount

M.3 Electrical test

M.3.1 General

The condoms are initially screened electrically to detect holes. A condom that has no holes acts as an insulator and allows no current to flow in an electrical circuit. A condom with a hole will allow a current to pass.

Condoms that fail the electrical test are then tested by the method outlined in [M.2.4](#) to confirm the presence or absence of a hole. A decision on whether a condom has a hole or not, cannot be made on the basis of the electrical conductivity part of the test alone. The presence of a hole shall be confirmed by the water leak test.

M.3.2 Apparatus

M.3.2.1 Electrical testing equipment, for example as shown in [Figures M.2](#) and [M.3](#).

The parameters are: Voltage ($10 \pm 0,1$) V d.c.; Resistance ($10 \pm 0,5$) k Ω . The voltmeter shall have an accuracy of ± 3 mV and an impedance of at least 1 M Ω .

M.3.2.2 Electrolyte solution, consisting of an aqueous sodium chloride solution [$\rho_{\text{NaCl}} = 10$ g/dm³] at (25 ± 5) °C is recommended but a solution of suitable electrolyte with equivalent conductivity may be used as an alternative [$\rho_{\text{Na}_2\text{SO}_4} = (15,4 \pm 1,0)$ g/dm³].

M.3.3 Procedure

M.3.3.1 Inspect the individual containers and record any that have visibly open seals.

M.3.3.2 Move the condom inside the individual container such that it is away from the area where the container is to be torn. Tear the container and remove the condom.

Do not use scissors or other sharp instruments to open the package. Wear suitable gloves or finger cots while handling the condom.

M.3.3.3 Unroll the condom ensuring that it is not excessively stretched in any direction.

M.3.3.4 Examine the condom visually under normal or corrected vision. Deem any condom that exhibits a visible hole or tear a failure and discontinue the test.

M.3.3.5 Record condoms with visible defects (see [3.15](#)) other than holes and tears.

M.3.3.6 Fit the open end of the condom onto the mount ([M.3.2.1](#)) so that the condom is suspended open end upwards.

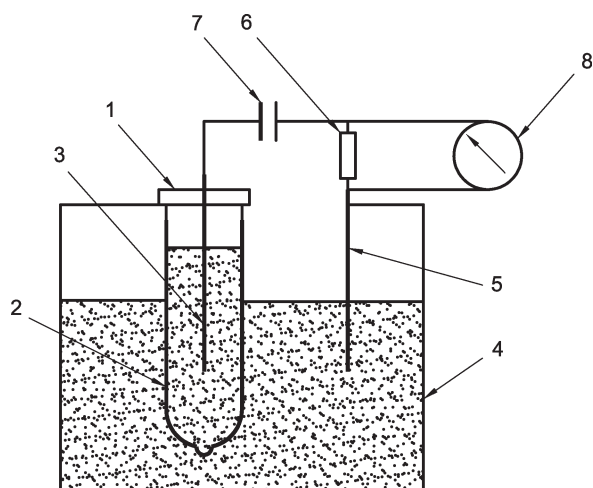

Key

- 1 support (see [Figure M.3](#))
- 2 condom filled with electrolyte fixed on support
- 3 electrode fixed to support
- 4 container with electrolyte
- 5 electrode
- 6 10 kΩ resistor
- 7 stable 10 V voltage supply
- 8 voltmeter with an impedance of at least 1 MΩ

Figure M.2 — Schematic diagram of electrical testing equipment

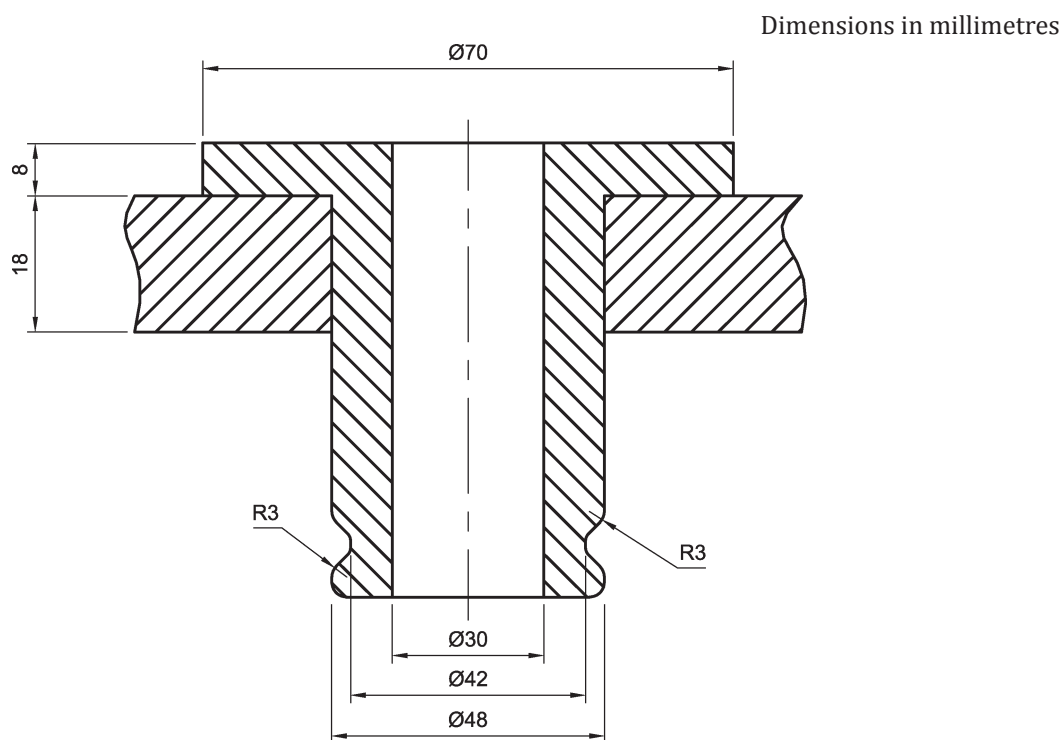

Figure M.3 — Example of means of attaching the condom to the support

M.3.3.7 Add the volume of electrolyte ([M.3.2.2](#)) specified in [Table M.2](#) within a tolerance of $\pm 10 \text{ cm}^3$ to the condom. Allow any electrolyte that does not flow into the condom to form a pressure head in the mount. Record any condom that leaks during filling as non-compliant. After all the electrolytes have been added, apply a 10 V d.c.-stabilized continuous voltage source in series with a 10 k Ω high precision electrical resistance between the electrode in the container and the electrode inside the condom. Submerge the condom into the container containing the electrolyte such that all but at least 25 mm from the open end is submerged.

Table M.2 — Fill volumes for conducting the electrical test

Condom length mm	Electrolyte volume cm ³			
	Mid-body condom width mm			
	45 to 49,5	50 to 55,5	56 to 65	65,5 to 75
160 to 185	300	300	350	475
186 to 210	300	300	400	525
211 to 240	300	350	450	600

For the purpose of this test, the mid-body width is the mean flat width rounded to the nearest 0,5 mm of 13 condoms measured in accordance with [Annex E](#) at a point (75 ± 5) mm from the closed end excluding the reservoir tip. The length of the condom is determined according to [Annex D](#).

Measure the voltage at the resistor as the condom is immersed and for up to (10 ± 2) s after full immersion. Record the highest voltage observed.

If a voltage equal to or greater than 50 mV is recorded subject the condom to the water test as described in [M.3.3.8](#).

M.3.3.8 Take hold of the condom by the closed end and, if necessary, gently stretch the condom to displace the electrolyte from the open end. Seal the condom by twisting it less than 25 mm from the open end, for approximately 1,5 revolutions, and remove it from the mount. Hold the end closed with one hand, or with a suitable clamping device ([M.2.2.4](#)). Wipe off any electrolyte on the outside on the condom with a soft absorbent cloth or paper. Test the condom as described in [M.2.4.2](#) and [M.2.4.3](#).

M.4 Expression of results

The test report shall include elements from [Clause 16](#) and the following particulars:

- the number of packages with visibly open seals;
- the number of condoms exhibiting a visible hole or tear before mounting on the apparatus;
- the number of condoms exhibiting a voltage equal to or greater than 50 mV (in the case of the electrical test);
- the number of condoms with observable leaks on the apparatus, which, when measured, are more than 25 mm from the open end (in the case of the visual test);
- the number of condoms which showed signs of leakage when tested by either of the methods outlined in [M.2.4.2](#) and [M.2.4.3](#) which, when measured, are more than 25 mm from the open end;
- the number of condoms with visible defects other than holes or tears, and their nature.

Annex N (normative)

Testing for package integrity

N.1 General

Package integrity refers to the possibility of breaches in sealed individual condom containers that might result in the leakage of lubricant. Such breaches will also cause the package to be permeable to oxygen. However, the test given in this annex cannot detect leakage due to micro-porosity or gas permeability of the materials used to construct the individual containers. Consequently, this test can be used only to detect leaks large enough to allow leakage of lubricant.

Seals that are visibly open not only allow the lubricant to leak but might also accelerate the degradation of the condom through exposure to oxygen. The individual containers are inspected for visibly open seals during testing for freedom from holes as described in [Annex M](#).

Several tests are under development. Pending conclusive validation that new tests provide greater sensitivity or consistency, package integrity shall be measured according to the following procedure. For packages formed from one or more layers of flexible laminate film a vacuum level corresponding to (20 ± 5) kPa absolute pressure shall be used. For other types of packaging it might be necessary to adjust the vacuum level to prevent otherwise good seals from bursting. Flexible packaging with little or no headspace cannot be reliably evaluated with this test method.

NOTE If a differential pressure gauge is used, the altitude of the location where the test equipment is located might cause the gauge reading to differ from the absolute pressure. If necessary, the effect of altitude should be corrected for.

Some leaks might not be detected by this procedure. Positive pressure inside the condom container after the vacuum is drawn might force the lubricant, if present, to plug small leaks. The size of the leak that can be detected is dependent upon the lubricant and the nature of the packaging material.

N.2 Test method

N.2.1 Apparatus

N.2.1.1 Vacuum chamber, capable of withstanding approximately one atmosphere pressure differential, fitted with a vacuum pump, a vacuum gauge and the possibility to inspect the interior during the test.

N.2.2 Reagent

N.2.2.1 Immersion fluid, (water) optionally containing a low foam wetting agent.

N.2.3 Test specimen

Condoms in their individual containers.

N.2.4 Conditioning

The test sample and test fluid shall be at equilibrium with normal room temperature.

N.2.5 Procedure

Submerge the individual containers in water contained in the vessel within the vacuum chamber. The uppermost part of the containers shall be covered by not less than 25 mm of water. If a dye is added to the water, leakage of water into the container will be easier to detect.

Two or more containers may be tested at the same time, provided that they are placed in such a manner that all parts of every container under test can be observed for leakage during the test.

Evacuate the chamber to an absolute pressure of (20 ± 5) kPa. As the vacuum increases, observe the containers for leakage in the form of a steady stream of bubbles. Isolated bubbles caused by entrapped air are not considered to be leaks.

Hold vacuum for (60 ± 5) s. Release the vacuum, remove the lid, and examine the containers for the presence of water inside.

N.2.6 Interpretation of results

If there are bubbles indicating leaks in a container as the vacuum increases, or when held at specified vacuum, then specimen fails the tests.

If the test fluid is visible inside a container, the container fails the test.

If there are no bubbles observed indicating leaks, and if no test fluid is visible inside a container, the container passes the test.

N.2.7 Test report

The test report shall include the elements of [Clause 16](#) and the following particulars:

- a) the numbers of containers with detected leaks from air-bubbles;
- b) the numbers of containers with detected leaks of fluid inside the container.
- c) the numbers of containers with visibly open seals.

Annex O (informative)

Calibration of air inflation equipment for determination of bursting volume and pressure

0.1 System check algorithm

Due to the diversity of equipment used by different laboratories, it is not practical to define all calibration and verification procedures.

The steps described in [0.2](#) to [0.7](#) and listed in [Figure 0.1](#), if performed in order, are an example of suitable system checks for verification, audit, and calibration which apply to many systems. The algorithm might have to be adapted to suit individual equipment configurations. Some systems might benefit from the installation of additional equipment, such as tees, isolating valves or manual control switches, to facilitate system checking.

In-house calibrations should be done at appropriate intervals, or whenever there is a reason to doubt the reading on an instrument.

0.2 Clamp slip force check

This test ensures that the condom length does not vary significantly during inflation and consists of making a mark on a condom as close as possible to the top of the collar, inflating the condom till it is near to bursting and observing if the mark has moved.

0.3 Inflation length check

This is a measurement, either on the test head or on the length-measuring mandrel, that verifies that 150 mm of condom is being inflated, i.e. that the length limiter is properly set, that the condom is not stretched by the clamping equipment, and that it is not being blown out of position before the clamp grips it.

0.4 Cuff leak check

This is a check that inflated cuffs do not leak air, especially into the condom. If the cuff and the air supply can be actuated separately, it is possible to check the cuff by turning on the air supply, isolating the cuff, and then observing it to see that it is still inflated after 5 min.

0.5 Air supply leak check

This step checks that there are no leaks in the air supply system and the pressure-sensing system that would cause an error in the measured volume.

0.6 Pressure gauge calibration

Pressure gauges or transducers can be checked regularly against a reference meter, connected in parallel with the gauge or transducer. A convenient and accurate reference is a water-tube manometer. The whole range of pressures encountered should be checked, either by placing a variable constriction over the test head or by inflating a condom (or two, one over the other) in stages.

0.7 Air flowrate adjustment and calibration

If the system relies on timing the inflation and multiplying by the flowrate, the flowrate needs to be known accurately; if, however, total volume is measured, it needs only to be within the stipulated range. It is advisable to set the flowrate around the centre of the allowable range, to allow for fluctuations due to ambient conditions.

Flowrate calibration is conveniently carried out using a suitable variable area flowmeter (rotameter) calibrated against a certified instrument. Rotameters are simple in construction, having few moving parts, and much of the critical equipment inside the meter is directly visible to the user. Volume meters may also be used.

The calibrating meter should be attached directly to the condom test head, where the condoms are normally mounted. Suitable stands and connecting hoses (with minimal pressure drop) might be necessary. If there is no permanent in-line meter, it is important to verify that the connection of the meter does not alter the flowrate significantly.

Changes in ambient conditions might affect the flowrate slightly, and on systems that rely on elapse of time to bursting, flowrate should be checked and recalculated twice daily, and whenever there are major weather changes.

0.8 In-line volume or flowrate meter calibration

For systems equipped with an in-line volume meter (for example, a diaphragm meter or a turbine meter), the meter's accuracy may be checked against the rotameter (or other reference meter) cited above. The test defines volume as the quantity of air delivered to the condom, and either it should be measured at the test head, or a correction should be made (using the ideal gas law) for any expansion between the volume meter and the test head. The pressure drop between the volume meter and the test head should be ascertained by a pressure gauge at the volume meter.

In-line rotameters, like calibrating rotameters, are governed by the rotameter equation. A correction should be made for the pressure and temperature under which the rotameter is operating, and for the expansion between the in-line meter and the test head.

0.9 Timer check

Stopwatches or electric timers should be checked against nationally certified timers (for example, telephone clocks or broadcast time signals).

0.10 Verification of automatic recording

On systems where results (of pressures, volumes, or times) are recorded automatically using computers or other equipment, it is necessary to check that the quantities recorded are actually those current at the time of bursting. This should be done for each test head in the system. The bursting volume (or time, as appropriate to the system) and the bursting pressure should be observed for five condoms on each head. The results should be compared with the automatically recorded values.

0.11 Important equations

If a gas experiences a drop in pressure as it flows, it will expand. The flowrate and the pressure are related by the ideal gas law:

$$p_1 \times q_1 = p_2 \times q_2 \quad (0.1)$$

where

p_1 and q_1 are the pressure and flowrate at point 1 in the system;

p_2 and q_2 are the pressure and flowrate at point 2.

The reading on a rotameter depends on the pressure and temperature of the gas flowing through it. If a rotameter is calibrated at pressure p_0 and temperature T_0 but the actual conditions where the measurement is being made are p_m and T_m then the true flowrate, Q , is related to the flowrate indicated, q , by the following equation:

$$Q = q \sqrt{\frac{p_0 T_m}{p_m T_0}} \quad (0.2)$$

NOTE All pressures in the above equation are absolute pressures.

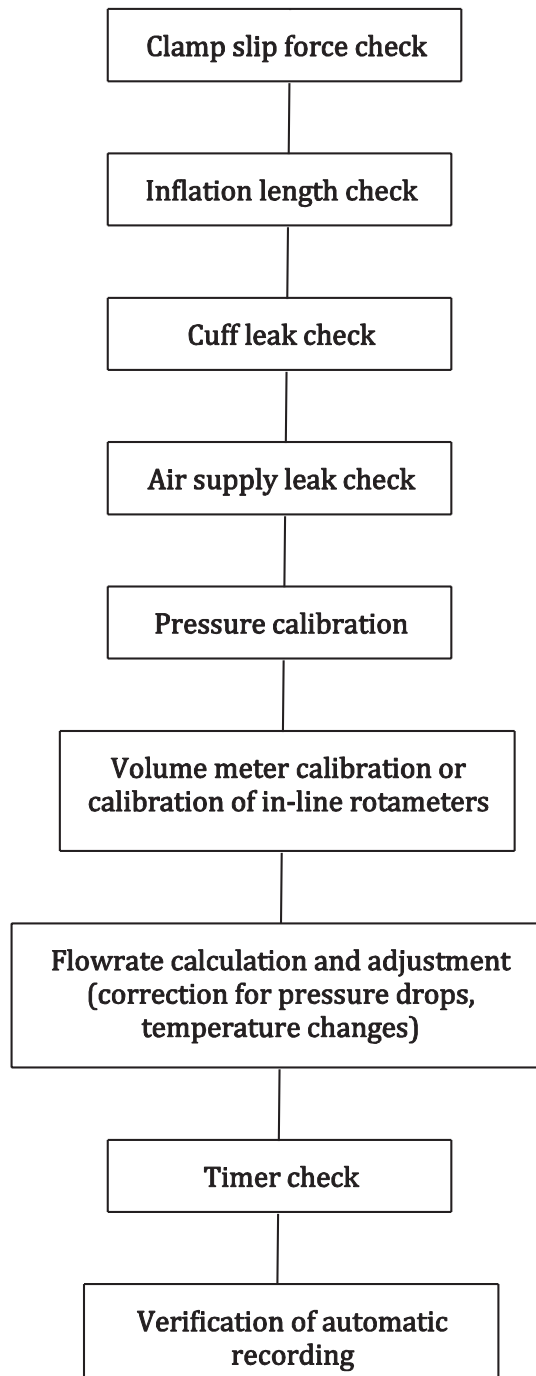

NOTE Some items, such as elimination of leaks, are a prerequisite to others, such as calibration of volume and pressure readings, but others, such as timer checking, inflation length and verification of automatic recording, can be done independently of most other checks.

Figure O.1 — List of periodic checks

Annex P (informative)

Recommendations for testing condoms that fall outside of the size ranges specified in ISO 4074

P.1 General

Condoms that have a mid-body width less than 45 mm and/or are shorter than 160 mm excluding the reservoir tip can be marketed at the discretion of the appropriate regulatory authorities or notified bodies. Condoms shorter than 160 mm might provide reduced levels of protection against sexually transmitted infection if the full length of the penis is not covered.

P.2 Bursting properties

The bursting volumes and pressures specified in [Clause 10](#) are not applicable for condoms that have a mid-body width less than 45,0 mm and/or are shorter than 160 mm excluding the reservoir tip.

Guidelines for bursting pressures and volumes for these condoms are given in [Tables P.1](#) and [P.2](#). These limits have been estimated on the assumption that the bursting volume is approximately proportional to the width of the condom squared multiplied by the length inflated, and the bursting pressure is inversely proportional to the width. The volumes have been calculated to be equivalent to 18 dm³ and 1,0 kPa for condoms with a mid-body width of 52 mm to 53 mm and an inflation length of 150 mm.

The mid-body width is the mean flat width rounded to the nearest 0,5 mm of 13 condoms measured in accordance with [Annex E](#) at a point equal to half the inflation length ± 5 mm from the closed end, excluding the reservoir tip. The inflation lengths vary depending on the length of the condoms under test and are given in [Tables P.1](#) and [P.2](#). The length of the condom is determined according to [Annex D](#). The supporting rod or mandrel, as described in [H.2.1 c\)](#), determines the length of condom that is inflated during the test. Rods or mandrels of different length may be used to control the inflation length. For condoms with widths less than 45 mm, the rod or mandrel should have a diameter of (20 ± 2) mm.

When determined in accordance with [Annex H](#), the bursting pressure and the bursting volume should not be less than the values given in [Tables P.1](#) and [P.2](#).

Table P.1 — Minimum bursting pressure for condoms

Length of condom mm	Inflation length mm	Bursting pressure kPa				
		Width mm				
		40 to 44,5	45 to 49,5	50 to 55,5	56 to 65	65,5 to 75
60 to 85	50	1,1	1,0	1,0	1,0	0,8
86 to 110	75	1,1	1,0	1,0	1,0	0,8
111 to 135	100	1,1	1,0	1,0	1,0	0,8
136 to 159	125	1,1	1,0	1,0	1,0	0,8

NOTE The length of the rod or mandrel described in [H.2.1 c\)](#) may be changed to achieve the required inflation length. See [Annex H](#) for more details.

Table P.2 — Minimum bursting volumes for condoms

Length of condom mm	Inflation length mm	Bursting volume dm ³				
		Width mm				
		40 to 44,5	45 to 49,5	50 to 55,5	56 to 65	65,5 to 75
60 to 85	50	4,0	5,0	6,0	7,0	9,0
86 to 110	75	7,0	8,0	9,0	11,0	14,0
111 to 135	100	9,0	11,0	12,0	15,0	18,0
136 to 159	125	11,0	13,0	15,0	18,0	23,0

NOTE The length of the rod described in [H.2.1 c](#) may be changed to achieve the required inflation length. See [Annex H](#) for more details.

P.3 Freedom from holes test

The volume of water or electrolyte specified in [Annex M](#) for the freedom from holes tests are not applicable for condoms that have a mid-body width less than 45 mm and/or are shorter than 160 mm excluding the reservoir tip.

Guidelines for fill volumes for these condoms are given in [Table P.3](#). These limits have been estimated on the assumption that the fill volume is approximately proportional to the mid-body width of the condom squared multiplied by its length.

The mid-body width is the mean flat width rounded to the nearest 0,5 mm of 13 condoms measured in accordance with [Annex E](#) at a point equal to half the nominal length of the condom specified by the manufacturer, excluding the reservoir tip, within a tolerance of ± 5 mm. The length of the condom is determined according to [Annex D](#).

Table P.3 — Fill volumes for conducting freedom from holes testing

Condom length mm	Water/electrolyte volume cm ³				
	Condom width mm				
	40 to 44,5	45 to 49,5	50 to 55,5	56 to 65	65,5 to 75
60 to 85	75	100	125	175	225
86 to 110	100	125	150	225	275
111 to 135	125	150	200	250	350
136 to 159	150	200	250	300	400

Bibliography

- [1] ISO 5893, *Rubber and plastics test equipment — Tensile, flexural and compression types (constant rate of traverse) — Specification*
- [2] ISO/TR 8550 (all parts), *Guide on the selection and usage of acceptance sampling systems for inspection of discrete items in lots*
- [3] ISO 11737-1:2006, *Sterilization of medical devices — Microbiological methods — Part 1: Determination of a population of microorganisms on products*
- [4] ISO 13485, *Medical devices — Quality management systems — Requirements for regulatory purposes*
- [5] ISO 14971, *Medical devices — Application of risk management to medical devices*
- [6] ISO 16038, *Rubber condoms — Guidance on the use of ISO 4074 in the quality management of natural rubber latex condoms*
- [7] EN 1041, *Information supplied by the manufacturer of medical devices*
- [8] ASTM D3492, *Standard specification for rubber contraceptives (male condoms)*
- [9] European Pharmacopoeia, 6, 2008 (Ph. Eur. 2008, para. 2.6.12)
- [10] German Pharmacopoeia (DAB), 1996: V2.1.8.1 and V2.1.8.2
- [11] United States Pharmacopoeia, 31 (2008) *Specified organisms test <62>*
- [12] British Pharmacopoeia, 2010 Volume IV, Appendix XVI, B1 and B2
- [13] Drug Development and Industrial Pharmacy, 24(4), 313-325 (1998), *Extension of the International conference on harmonization tripartite guideline for stability testing of new drug substances and products to countries of climate zones III and IV*
- [14] Drug Development and Industrial Pharmacy, 19(20), 2795-2830 (1993), *Storage conditions for stability testing in the EC, Japan and USA*
- [15] Data supplied by Tun Abdul Razak Research Centre, Brickendonbury, Herford, UK, SG13 8NL
- [16] JCGM 100:2008 GUM 1995 with minor corrections *Evaluation of measurement data - Guide to the expression of uncertainty in measurement*
- [17] ISO 9000, *Quality management systems — Fundamentals and vocabulary*
- [18] ISO 3534-2:2006, *Statistics — Vocabulary and symbols — Part 2: Applied statistics*

