

INTERNATIONAL
STANDARD

ISO
27427

Third edition
2013-12-15

**Anaesthetic and respiratory
equipment — Nebulizing systems and
components**

*Matériel d'anesthésie et de réanimation respiratoire — Systèmes de
nébulisation et ses composants*



Reference number
ISO 27427:2013(E)

© ISO 2013



COPYRIGHT PROTECTED DOCUMENT

© ISO 2013

All rights reserved. Unless otherwise specified, no part of this publication may be reproduced or utilized otherwise in any form or by any means, electronic or mechanical, including photocopying, or posting on the internet or an intranet, without prior written permission. Permission can be requested from either ISO at the address below or ISO's member body in the country of the requester.

ISO copyright office
Case postale 56 • CH-1211 Geneva 20
Tel. + 41 22 749 01 11
Fax + 41 22 749 09 47
E-mail copyright@iso.org
Web www.iso.org

Published in Switzerland

Contents

Page

Foreword	iv
Introduction	v
1 Scope	1
2 Normative references	1
3 Terms and definitions	2
4 General requirements and requirements for test	4
4.1 Risk management.....	4
4.2 Test methods and alternatives.....	5
4.3 Electrical safety.....	5
4.4 Mechanical safety.....	5
4.5 Pneumatic safety.....	6
4.6 Protection against inadvertent adjustments.....	6
4.7 Usability.....	6
5 Marking	6
5.1 Symbols.....	6
5.2 Marking on the device.....	6
5.3 Labelling on the packaging or individual pack.....	7
5.4 Instructions for use, inserts, and accompanying documents.....	8
6 Construction requirements	11
6.1 Materials.....	11
6.2 Connectors.....	11
6.3 Rotary controls.....	13
7 Cleaning, sterilization, and disinfection	14
8 Biocompatibility	14
Annex A (informative) Rationale	15
Annex B (normative) Diameters of respirable fraction particles	19
Annex C (normative) Test methods for aerosol output and aerosol output rate	20
Annex D (normative) Test methods for particle sizing	23
Annex E (informative) Hazard identification for risk assessment	32
Annex F (informative) Classification of general purpose nebulizers	38
Annex G (informative) Environmental aspects	40
Annex AA (informative) Conformance to essential principles	42
Bibliography	46

Foreword

ISO (the International Organization for Standardization) is a worldwide federation of national standards bodies (ISO member bodies). The work of preparing International Standards is normally carried out through ISO technical committees. Each member body interested in a subject for which a technical committee has been established has the right to be represented on that committee. International organizations, governmental and non-governmental, in liaison with ISO, also take part in the work. ISO collaborates closely with the International Electrotechnical Commission (IEC) on all matters of electrotechnical standardization.

The procedures used to develop this document and those intended for its further maintenance are described in the ISO/IEC Directives, Part 1. In particular the different approval criteria needed for the different types of ISO documents should be noted. This document was drafted in accordance with the editorial rules of the ISO/IEC Directives, Part 2 (see www.iso.org/directives).

Attention is drawn to the possibility that some of the elements of this document may be the subject of patent rights. ISO shall not be held responsible for identifying any or all such patent rights. Details of any patent rights identified during the development of the document will be in the Introduction and/or on the ISO list of patent declarations received (see www.iso.org/patents).

Any trade name used in this document is information given for the convenience of users and does not constitute an endorsement.

For an explanation on the meaning of ISO specific terms and expressions related to conformity assessment, as well as information about ISO's adherence to the WTO principles in the Technical Barriers to Trade (TBT) see the following URL: [Foreword - Supplementary information](#)

The committee responsible for this document is ISO/TC 121, *Anaesthetic and respiratory equipment*, Subcommittee SC 2, *Airways and related equipment*.

This third edition cancels and replaces the second edition (ISO 27427:2010), of which it constitutes a major revision.

Introduction

Nebulizers are widely used to deliver drugs and vaccines in an aerosol form to humans through the respiratory system. **Nebulizers** are also used for diagnostic purposes using radioisotopes for lung challenge tests. These drugs can be in the form of a solution, suspension or emulsion. **Aerosol** inhalation is the preferred route of administration for some drugs. Some drugs are intended for treatment of systemic diseases and other drugs are intended to treat respiratory diseases. To achieve the intended treatment, **aerosol** particles have to be deposited in specific parts of the respiratory tract. Different size particles tend to deposit in different parts of the respiratory system; therefore, the performance profile and the intended use of the **nebulizer** have to be defined by the manufacturer and specified in the accompanying documentation.

This International Standard is based on Reference [29]. This International Standard was developed to cover “general purpose” **nebulizers** and is based on adult test parameters which are likely to be different than stated when testing for paediatric or infant patient populations. It was specifically written to ensure that the results of the various tests declared by the manufacturer are meaningful to the users and buyers of **nebulizers**.

The objectives of this International Standard are to ensure

- suitability of the **nebulizers** for the intended use as disclosed by the manufacturer,
- safety, particularly for **electrically powered nebulizers**,
- compatibility between the materials of the components and the dispensed liquid, and
- biocompatibility of the materials of the components that come into contact with the human body.

Important changes were made to the original EN standard in recognition of the advances in test devices such as lasers and low-flow impactors that allow manufacturers to use different test methods, provided these alternate methods are validated against the methods specified in this International Standard.

Terms defined in this International Standard are set in **bold type**.

Throughout this International Standard, text for which rationale is provided in [Annex A](#) is indicated by an asterisk (*).

Anaesthetic and respiratory equipment — Nebulizing systems and components

1 Scope

*This International Standard specifies requirements for the safety and performance testing of general purpose **nebulizing systems** intended for continuous or breath-actuated delivery of liquids, in **aerosol** form, to humans through the respiratory system.

This International Standard includes **gas-powered nebulizers** which can be powered by, e.g., compressors, pipeline systems, cylinders, etc., and **electrically powered nebulizers** [e.g., spinning disc, ultrasonic, vibrating mesh (active and passive), and capillary devices] or **manually powered nebulizers**.

This International Standard does not specify the minimum performance of **nebulizing systems**.

*This International Standard does not apply to devices intended for nasal deposition.

This International Standard does not apply to devices intended solely to provide humidification or hydration by providing water in **aerosol** form.

NOTE ISO 8185 covers this.^[3]

*This International Standard does not apply to drug-specific **nebulizers** or their components (e.g., metered dose inhalers, metered liquid inhalers, dry powder inhalers).

2 Normative references

The following documents, in whole or in part, are normatively referenced in this document and are indispensable for its application. For dated references, only the edition cited applies. For undated references, the latest edition of the referenced document (including any amendments) applies.

ISO 5356-1, *Anaesthetic and respiratory equipment — Conical connectors — Part 1: Cones and sockets*

ISO 5356-2, *Anaesthetic and respiratory equipment — Conical connectors — Part 2: Screw-threaded weight-bearing connectors*

ISO 5367, *Anaesthetic and respiratory equipment — Breathing sets and connectors*

ISO 7396-1, *Medical gas pipeline systems — Part 1: Pipeline systems for compressed medical gases and vacuum*

ISO 9170-1, *Terminal units for medical gas pipeline systems — Part 1: Terminal units for use with compressed medical gases and vacuum*

ISO 10524-1, *Pressure regulators for use with medical gases — Part 1: Pressure regulators and pressure regulators with flow-metering devices*

ISO 10524-3, *Pressure regulators for use with medical gases — Part 3: Pressure regulators integrated with cylinder valves*

ISO 10993-1, *Biological evaluation of medical devices — Part 1: Evaluation and testing within a risk management process*

ISO 11135-1, *Sterilization of health care products — Ethylene oxide — Part 1: Requirements for development, validation and routine control of a sterilization process for medical devices*

ISO 27427:2013(E)

ISO 11137-1, *Sterilization of health care products — Radiation — Part 1: Requirements for development, validation and routine control of a sterilization process for medical devices*

ISO 11137-2, *Sterilization of health care products — Radiation — Part 2: Establishing the sterilization dose*

ISO 11137-3, *Sterilization of health care products — Radiation — Part 3: Guidance on dosimetric aspects*

ISO 11607-1, *Packaging for terminally sterilized medical devices — Part 1: Requirements for materials, sterile barrier systems and packaging systems*

ISO 14971, *Medical devices — Application of risk management to medical devices*

ISO 15001, *Anaesthetic and respiratory equipment — Compatibility with oxygen*

ISO 15223-1, *Medical devices — Symbols to be used with medical device labels, labelling and information to be supplied — Part 1: General requirements*

ISO 17665-1, *Sterilization of health care products — Moist heat — Part 1: Requirements for the development, validation and routine control of a sterilization process for medical devices*

ISO 23328-1, *Breathing system filters for anaesthetic and respiratory use — Part 1: Salt test method to assess filtration performance*

ISO 80369-1, *Small-bore connectors for liquids and gases in healthcare applications — Part 1: General requirements*

IEC 60601-1:2005, *Medical electrical equipment — Part 1: General requirements for basic safety and essential performance*

IEC 60601-1-2:2006+A1:2012, *Medical electrical equipment — Part 1-2: General requirements for basic safety and essential performance — Collateral standard: Electromagnetic compatibility — Requirements and tests*

IEC 60601-1-6, *Medical electrical equipment — Part 1-6: General requirements for basic safety and essential performance — Collateral standard: Usability*

IEC 60601-1-8, *Medical electrical equipment — Part 1-8: General requirements for basic safety and essential performance — Collateral Standard: General requirements, tests and guidance for alarm systems in medical electrical equipment and medical electrical systems*

IEC 62366, *Medical devices — Application of usability engineering to medical devices*

EN 556-1, *Sterilization of medical devices — Requirements for medical devices to be designated “STERILE” — Part 1: Requirements for terminally sterilized medical devices*

EN 13544-2, *Respiratory therapy equipment — Part 2: Tubing and connectors*

EN 15908, *Anaesthetic and respiratory equipment. Non-interchangeable screw-threaded (NIST) low-pressure connectors for medical gases*

ENV 737-6, *Medical gas pipeline systems — Part 6: Dimensions and allocation of probes for terminal units for compressed medical gases and vacuum*

CGA V-5-2005, *Diameter Index Safety System — Noninterchangeable Low Pressure Connections for Medical Gas Applications*

3 Terms and definitions

For the purposes of this document, the following terms and definitions apply.

3.1**aerosol**

suspension of particles in gas

Note 1 to entry: Particles can be liquid or solid.

Note 2 to entry: The gas can be the driving gas or ambient air.

3.2**aerosol outlet port**

outlet of the **nebulizing system** through which the **aerosol** is emitted

3.3***aerosol output**

mass or volume of **aerosol** emitted by the **nebulizing system** at the **aerosol outlet port** for the given fill volume

3.4***aerosol output rate**

mass or volume of **aerosol** emitted by the **nebulizing system** per unit of time

3.5**breath-actuated nebulizer**

nebulizer triggered by a respiratory parameter

Note 1 to entry: Examples of this classification are found in [Annex F](#).

3.6**continuous nebulizer**

nebulizer in which **aerosol** is delivered continuously over multiple inhalation/exhalation breathing cycles or over long periods

3.7**electrically powered nebulizer**

nebulizer that operates by means of electrical power

Note 1 to entry: **Electrically powered nebulizers** include ultrasonic, vibrating mesh and capillary-type devices.

3.8**gas-powered nebulizer**

nebulizer in which the **aerosol** is generated by compressed gas

3.9**liquid container**

part of the **nebulizer** that contains the liquid for nebulization

3.10**manually powered nebulizer**

nebulizer that operates by means of human power

3.11**mass median aerodynamic diameter****MMAD**

particle size at which 50 % of the mass of the active component are contained in droplets of smaller or equal aerodynamic diameter

3.12**maximum fill volume**

maximum volume of liquid, expressed in millilitres, in the **liquid container** when the **nebulizer** is filled to its maximum filling level

**3.13
nebulizer**

device that converts a liquid to an **aerosol**

Note 1 to entry: A nebulizer is also known as an **aerosol** generator.

**3.14
nebulizing system**

device, including the **nebulizer** and all other components, up to and including the **aerosol outlet port**, required to make the **aerosol** available for inhalation

Note 1 to entry: Airway devices (e.g., masks, tracheal and tracheostomy tubes, supralaryngeal airways) and breathing systems are not part of the **nebulizing system**.

**3.15
*percentage of fill volume emitted**

aerosol output expressed as a percentage of the fill volume recommended by the manufacturer that is emitted by the **nebulizer**

**3.16
*residual volume**

estimated volume of liquid remaining in the **nebulizing system** when the **nebulizer** stops generating an **aerosol**

**3.17
*respirable fraction**

fraction of **aerosol** droplets below 5 µm in diameter expressed as a percentage of the total **aerosol distribution**

Note 1 to entry: The **respirable fraction** can be converted to a percentage (%) by multiplying by 100.

**3.18
*test solution**

aqueous solution used for the type-tests to characterize **aerosol output**, **aerosol output rate**, and particle sizing

Note 1 to entry: See [4.2.1.2](#), [5.4.2 j\)](#) and [k\)](#), [Annex C](#), and [Annex D](#).

**3.19
test substance**

active ingredient contained in the test solution

**3.20
validation**

confirmation through the provision of objective evidence that the requirements for a specific intended use or application have been fulfilled

Note 1 to entry: The term “validated” is used to designate the corresponding status.

Note 2 to entry: The use conditions for **validation** can be real or simulated.

4 General requirements and requirements for test

4.1 Risk management

4.1.1 General

Nebulizing systems and **nebulizers** shall, when transported, stored, installed, operated in normal use, and maintained according to the instructions of the manufacturer, present no risks that are not reduced

to an acceptable level using the risk management procedures in accordance with ISO 14971 and which are connected with their intended application, in normal and in single fault condition.

NOTE A situation in which a fault is not detected is considered a normal condition. Fault conditions/hazardous situations might remain undetected over a period of time and, as a consequence, might lead to an unacceptable risk. In that case, a subsequent detected fault condition needs to be considered as a single fault condition. Specific risk control measures need to be determined within the risk management process to deal with such situations.

4.1.2 Clinical evaluation

If applicable, a clinical evaluation shall be performed and the results documented in the technical documentation of the device.

Compliance is checked by inspecting the technical documentation of the device.

4.2 Test methods and alternatives

4.2.1 Test methods for aerosol output, aerosol output rate, and particle sizing

The type-test methods for **aerosol output**, **aerosol output rate**, and particle sizing in air are specified in [Annexes C](#) and [D](#).

4.2.1.1 *All type-test methods shall be performed on at least three representative devices of the same type.

4.2.1.2 *The type-test methods shall use a **test solution** of albuterol 0,1 % (M/V) concentration in 0,9 % sodium chloride solution or 2,5 % (M/V) sodium fluoride in distilled water with the provision that its use is declared in the accompanying documents. See [5.4.2 j](#)).

4.2.2 *Alternative test methods

The manufacturer can use type-test methods for **aerosol output**, **aerosol output rate**, and particle sizing different from those specified in [Annexes C](#) and [D](#).

Alternative test methods shall be **validated** against the test methods in [Annexes C](#) and [D](#) to demonstrate equivalency.

Demonstration of equivalency shall be included in the technical documentation of the manufacturer.

Evidence shall be provided (e.g. to regulatory authorities) upon request.

4.2.3 Calibration and setup

To establish confidence in the test method, it is recommended that mass balance procedures be incorporated during initial determinations. It is also recommended that occasional checks for system leaks and overall efficiency of analysis be performed.

4.3 Electrical safety

A **nebulizing system** that utilizes electrical power shall meet the requirements given in IEC 60601-1, in addition to the requirements given in this International Standard.

Compliance is checked by applying the tests given in IEC 60601-1.

4.4 Mechanical safety

Nebulizing systems shall comply with Clause 9 of IEC 60601-1:2005.

Compliance is checked by inspection.

4.5 Pneumatic safety

If it is declared by the manufacturer that a **nebulizing system** is intended to be connected directly to a pipeline system complying with ISO 7396-1 or a pressure regulator complying with ISO 10524-1 or ISO 10524-3, the **nebulizing system** shall meet the requirements of this International Standard for a pneumatic power supply having a range of 280 kPa (2,8 bar) to 600 kPa (6 bar) and shall cause no hazardous situation under single fault conditions of the medical gas supply, [i.e. up to 1 MPa (10 bar) inlet pressure].

4.6 Protection against inadvertent adjustments

Means of protection against inadvertent adjustment of controls which can create a hazardous output shall be provided.

EXAMPLE Acceptable mechanical control techniques include locks, shielding, friction loading, detents, pressure-sensitive finger pads, capacitive finger-switched microprocessor-oriented "soft" controls, and a specific sequence of key or switch operations.

Compliance is checked by visual inspection following the instructions for use.

4.7 Usability

4.7.1 The manufacturer shall address, in a usability engineering process, the risk resulting from poor usability according to IEC 60601-1-6 and IEC 62366.

4.7.2 The ON/OFF switch and/or control devices shall be positioned in such a way as to be safely operated without hesitation or loss of time and without ambiguity.

4.7.3 Control devices (if fitted) shall be so arranged that their layout, travel, and resistance to operation are compatible with the action to be performed, taking account of ergonomic principles.

Compliance is checked by inspecting the usability engineering file.

5 Marking

5.1 Symbols

ISO 15223-1 and 6.4 of IEC 60601-1:2005 apply.

Compliance is checked by inspection.

5.2 Marking on the device

Nebulizers, nebulizing systems, and components shall contain durable and legible marking on the device to include the following.

5.2.1 Marking of the nebulizer and components

The following shall be marked on the **nebulizer** and components:

- a) an arrow showing the direction of gas flow on all operator-detachable flow direction-sensitive components, breathing attachments or parts (e.g. facemask or mouthpiece one-way valve, etc.), unless manufactured to prevent incorrect assembly;
- b) the inlet and outlet, if gas-specific;
- c) the **maximum fill volume** level on the **liquid container** of the **nebulizer**.

5.2.2 Marking of the controls and instruments

If applicable, controls and instruments shall be legibly marked as

- a) the gas supply pressures, in kilopascals (kPa),
- b) the pressures in breathing systems, in hectopascals (hPa),
- c) the flows, in litres per minute (l/min),
- d) if supplied, the air entrainment/oxygen dilution valves, in percent oxygen (% O₂), and
- e) the power and/or control devices marked with the relevant symbols.

Compliance is checked by inspection. All displayed qualitative or quantitative information, values, functions, and/or markings shall be discernible or identifiable to an OPERATOR with 6-6 (20/20) vision (corrected, if necessary) from a distance of 1 m at a light level of 215 lx, when viewing the information, markings, etc., perpendicular to and including 15° above, below, left, and right of the normal line of sight of the OPERATOR. See IEC 60601-1, 7.1.2 and 7.1.3.

5.3 Labelling on the packaging or individual pack

The following shall be labelled on the packaging or individual pack:

- a) the name or trademark and address of the manufacturer;
- b) the device identification and content information;
- c) the batch code, preceded by the word "LOT", or serial number;
- d) the word "STERILE", if appropriate (It is recommended that the method of sterilization be given.);
- e) if applicable, an indication that the device is for single use;

NOTE The manufacturer's attention is drawn to the regulatory provision, requiring that the indication of single use be consistent across the European Community.

- f) the device packaging and/or labelling to differentiate between the same or similar products, both sterile and non-sterile, placed on the market by the same manufacturer;
- g) the expiry date, expressed as the year and month, if the device is sensitive to storage or shelf life;
- h) any special storage and/or handling conditions;
- i) any warning and/or precaution (e.g. compatibility with the use of oxygen mixtures and compatibility between oxygen and administered drugs);
- j) for packages containing parts made of antistatic or conductive material, the word "ANTISTATIC" or "CONDUCTIVE";
- k) if natural rubber latex is incorporated in parts of the medical devices that come directly or indirectly into contact with the patient, the device shall be labelled accordingly;
- l) if phthalates are incorporated in parts of the medical devices that come directly or indirectly into contact with the patient, the device shall be labelled accordingly;
- m) for **nebulizing systems** intended to be connected to an electrical power source, the nominal power expressed in Watts (W) or kilowatts (kW), as appropriate;
- n) for **nebulizing systems** intended to be connected to the supply mains, the rated supply voltage(s) or rated voltage range(s) to which they can be connected, expressed in Volts (V).

Compliance is checked by inspection.

5.4 Instructions for use, inserts, and accompanying documents

Nebulizers, nebulizing systems, and components shall be accompanied by instructions for use, inserts, or accompanying documents that include:

5.4.1 General information

- a) the date of issue or the date of latest revision of the instructions, inserts, or accompanying documents;
- b) the name or trademark and address of the manufacturer;
- c) for devices imported into the European Union, the name and address of the person responsible and of the authorized representative of the manufacturer established within the European Community;
- d) the purpose and the intended use of the device and parts thereof, as determined by the manufacturer, including the power and/or control devices;

EXAMPLE Intended use categories include, but are not limited to:

- patient populations,
- environment of use,
- single-use disposable,
- single-patient reuse, and
- multi-patient reuse.

- e) if applicable, the interdependence of controls;
- f) a statement that the **nebulizing system** is or is not suitable for use in a anaesthetic breathing system or a ventilator breathing system, see References [26] and [27];
- g) *if applicable, the maximum temperature above ambient reached in the nebulizing chamber under all operating conditions;
- h) the types of liquid (e.g. solution, suspension, and/or emulsion) the device is designed to nebulize;
- i) the **maximum fill volume** level, as marked on the **liquid container** of the **nebulizer**;
- j) if appropriate, the recommended fill volume for use;
- k) if handheld, an indication of the spatial orientation (e.g. vertical, horizontal, inverted) at which the **nebulizer** functions as intended;
- l) a statement that using a solution, suspension, or emulsion different from that recommended by the manufacturer, in particular, a suspension and/or high-viscosity solution, can alter the particle size distribution curve, the **mass median aerodynamic diameter (MMAD)**, **aerosol output**, and/or **aerosol output rate**, which can then be different from those disclosed by the manufacturer;
- m) a statement that **nebulizing systems** intended to be connected to a power source (electrical or pneumatic) shall be disconnected from the power source after use;
- n) the mass of the most usual configuration, in kilograms (kg).

5.4.2 Performance disclosures

- a) a statement to the effect that the following disclosures for **nebulizer** performance are based upon testing that utilizes adult ventilatory patterns and are likely to be different from those stated for paediatric or infant populations;

- b) the distribution of particles, in terms of percent of sampled mass, within each of the following size ranges: % >5 µm, % 2 µm to 5 µm, and % <2 µm when tested in accordance with [Annex D](#);
 - c) the **mass median aerodynamic diameter (MMAD)** and the geometric standard deviation (GSD) only if the distribution is unimodal and log-normal, as derived from the particle size distribution curve, when tested in accordance with [Annex D](#);
 - d) the **respirable fraction** performance of the nebulizer, when tested in accordance with [Annex D](#);
 - e) the **aerosol output** and **aerosol output rate** at the fill volume recommended by the manufacturer or 2 ml if a recommended fill volume is not provided, expressed as the mass of test substance collected and the mass of test substance collected per minute, when tested in accordance with [Annex C](#);
 - f) for **gas-powered nebulizers**, the **aerosol output** and **aerosol output rate** at the minimum, nominal, and maximum driving gas flows with the corresponding pressures, when tested in accordance with [Annex C](#);
 - g) the **percentage of fill volume emitted** per minute (e.g. 20 % of fill volume per minute) as the **aerosol output** in one minute divided by the fill volume recommended by the manufacturer or 2 ml if no fill volume is recommended, when tested in accordance with [Annex C](#);
 - h) for **gas-powered nebulizers**, the **percentage of fill volume emitted** and **percentage of fill volume emitted** per minute at the minimum, nominal, and maximum driving gas flows with the corresponding pressures, when tested in accordance with [Annex C](#);
 - i) the **residual volume** (in millilitres), when tested in accordance with [Annex C](#);
- NOTE **Aerosol output** fraction can then be calculated as the **aerosol output** divided by the mass (weight) of the liquid placed in the **nebulizer**.
- j) the **test solution** used to carry out the **nebulizer** performance type-tests in [Annexes C](#) and [D](#);
 - k) *if alternative test methods or **test solutions** have been used to demonstrate **nebulizer** performance, a demonstration of equivalency shall be included in the technical documentation of the manufacturer and shall be made available upon request;
 - l) for a **breath-actuated nebulizer**, the method of operation and relevant sensitivity;
 - m) *the maximum A-weighted sound pressure level, as derived from the test method in 9.6.2.1 of IEC 60601-1:2005;
 - n) for **nebulizers** intended for use with ventilators, a statement to the effect that the measured **aerosol output** and **aerosol output rate** are not intended to be used as basis to determine the correct dosage and that the **aerosol output** can differ when the nebulizer is used in combination with a ventilator.

5.4.3 Driving gas supply information

- a) the recommended driving gas(es);
- b) the minimum and maximum recommended driving gas pressures and flows;
- c) the pressure and flow characteristics of any gas power outlet under the worst-case conditions stated by the manufacturer;
- d) if applicable, a warning that oxygen or oxygen mixtures (O₂ > 23 %) should not be used as driving gas;^[36]
- e) if applicable, a statement of the composition and dryness specification for all gases to be supplied to the **nebulizer**;
- f) the service lifetime of the reusable parts.

5.4.4 Materials compatibility information

- a) the information about any precautions to be taken if there is a specific unusual risk associated with the compatibility between the materials of the components and the dispensed liquids;
- b) if applicable, a statement that the materials used in the components could not be compatible with solutions/suspensions/emulsions that have not been evaluated;
- c) a statement that identifies the residual risk if phthalates are incorporated in parts of the medical devices coming directly or indirectly into contact with the patient and if the device is used in the treatment of children or pregnant or nursing women;
- d) for single-use devices, the risks associated with the reuse or reprocessing of single-use devices.

NOTE For devices imported into the European Union, the manufacturer's attention is drawn to the regulatory provision, requiring that the indication of single use be consistent across the European Community.

5.4.5 Cleaning, disinfection, and sterilization information

- a) for **nebulizing systems** intended for single-patient reuse, recommended methods of cleaning and, if indicated, disinfection prior to reuse;
- b) for **nebulizing systems** intended for multi-patient reuse, recommended methods of cleaning and either disinfection or sterilization prior to reuse;
- c) the number of cycles of cleaning, disinfection, and/or sterilizations the **nebulizing system** will withstand;
- d) for **nebulizing systems** intended to be connected to a power source (electrical or pneumatic), cleaning, disinfection, and sterilization shall be carried out with the power source disconnected;
- e) for **nebulizing systems** not intended for reuse, the risks associated with cleaning and disinfection and/or sterilization prior to reuse.

5.4.6 Dismantling and reassembling information

- a) if applicable, procedures for disconnecting the **nebulizing system** from the power source (electrical or pneumatic), dismantling, and reassembly;
- b) recommended functional test(s) to be carried out after reassembly and before use;
- c) for **nebulizing systems** intended to be connected to a power source (electrical or pneumatic), dismantling and reassembling shall be carried out with the power source disconnected.

5.4.7 Monitoring, alarm, and protection devices

- a) the instructions for use shall contain the information required by IEC 60601-1-8, 5.2.1;
- b) the instructions for use shall contain details and characteristics of non-return valves and pressure-relief valves, if fitted.

5.4.8 Electromagnetic compatibility information

If applicable, the instructions for use shall include a warning statement to the effect that the functioning of this **nebulizer** can be affected by electromagnetic interference exceeding the levels specified in IEC 60601-1-2.

5.4.9 Device disposal information

The instructions for use shall include information about any precautions to be taken if there is a specific unusual risk associated with the disposal of a device.

5.4.10 Parts not integral to the nebulizing system disclosure

- a) a list of the parts that are not integral parts of the system and are necessary for correct use;
- b) a statement that these parts shall comply with the relevant requirements of this International Standard.

Compliance is checked by inspection.

6 Construction requirements

6.1 Materials

6.1.1 Materials for construction shall be compatible with the manufacturer's recommended gas(es) or gas mixture(s) and, if applicable, in compliance with ISO 15001.

Compliance is checked by inspection and by examination of the risk controls described in a risk assessment and associated verification and **validation** studies.

While intended to be used with drugs and cleaning agents, materials should be chosen to minimize risks due to toxicity.

6.1.2 Nebulizer components that come into contact with cleaning agents, sterilants, medical gases, and medicaments recommended by the manufacturer shall not degrade, affect performance, or present a hazard for the **nebulizer's** intended use.

NOTE Attention is drawn to substances which are carcinogenic, mutagenic, or toxic to reproduction. See also [5.4.4](#).

6.1.3 The recommended cleaning, disinfecting, or sterilizing agents shall not alter the performance of the **nebulizer system** outside the performance specification provided by the manufacturer.

Compliance is checked by inspection and by examination of the risk controls described in a risk assessment and associated verification and **validation** studies.

6.2 Connectors

6.2.1 Driving gas inlet connectors

The driving gas inlet connector of a **nebulizing system** shall be compatible with the gas delivery system to which it is intended to be connected and shall be one of the following (see [Figure 1](#)):

- a) the nut and nipple of a non-interchangeable screw-threaded (NIST) connector complying with EN 15908:2010;
- b) the nut and nipple of a Diameter Index Safety System (DISS) connector complying with CGA V-5-2005;
- c) a probe complying with ISO 9170-1, ENV 737-6, or the relevant national standard;
- d) *a nipple and end connector complying with EN 13544-2 or a small bore connector complying with ISO 80369-1.

6.2.2 Nebulizer system connectors

6.2.2.1 If intended for use in breathing sets, the **nebulizing system** connectors shall comply with ISO 5367. It shall not be possible to attach the **nebulizer** outlet to any device in a manner that does not allow an alternate pathway for exhalation. See [Figure 2](#).

6.2.2.2 If not intended for use in breathing systems, the **nebulizing system** connector shall not misconnect with connectors complying with ISO 5356-1, ISO 5356-2, or ISO 80369-1.

Compliance is checked by testing with ISO 80369-1, Annex B.

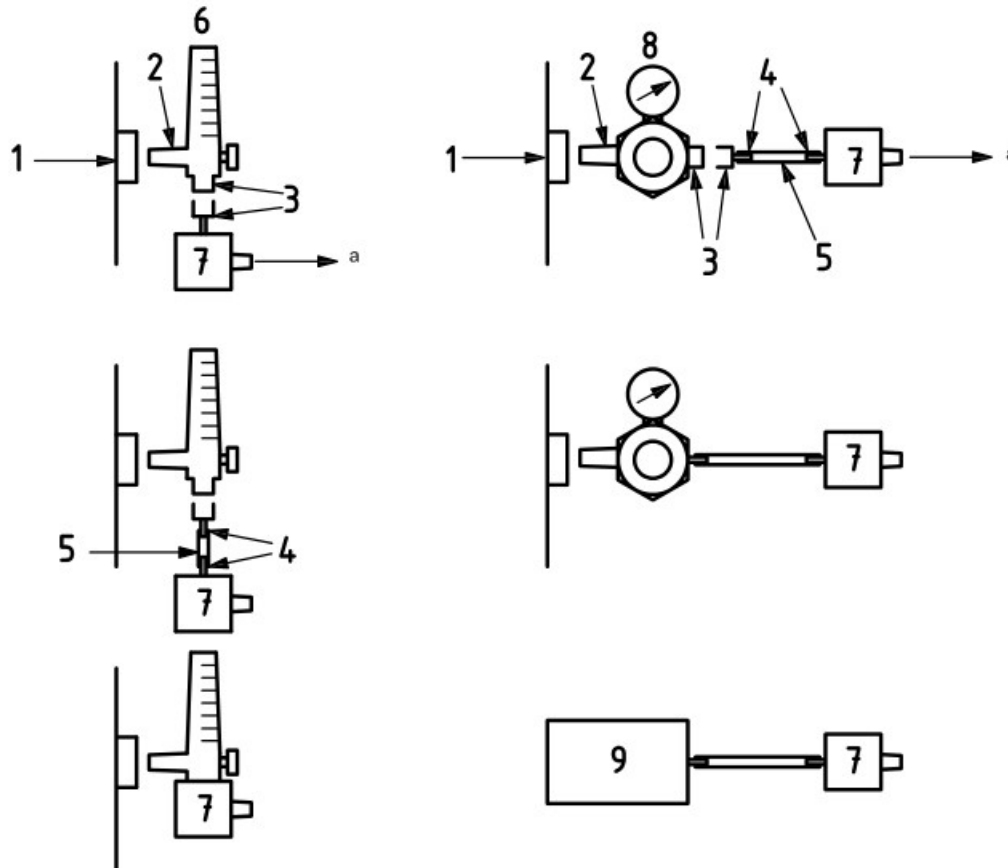

Key

- 1 terminal unit complying with ISO 9170-1 [on a pressure regulator or on an Medical Gas Pipeline System (MGPS)]
- 2 probe, DISS, or NIST (see ISO 9170-1, ENV 737-6, or EN 15908)
- 3 threaded connector (see EN 13544-2)
- 4 respiratory connector (see EN 13544-2 or ISO 80369-1)
- 5 hose (see EN 13544-2)
- 6 flowmeter (see ISO 15002)
- 7 **nebulizer**
- 8 pressure regulator (see ISO 10524-1)
- 9 compressor
- a To the patient.

Figure 1 — Examples of driving gas inlet connectors for nebulizer systems

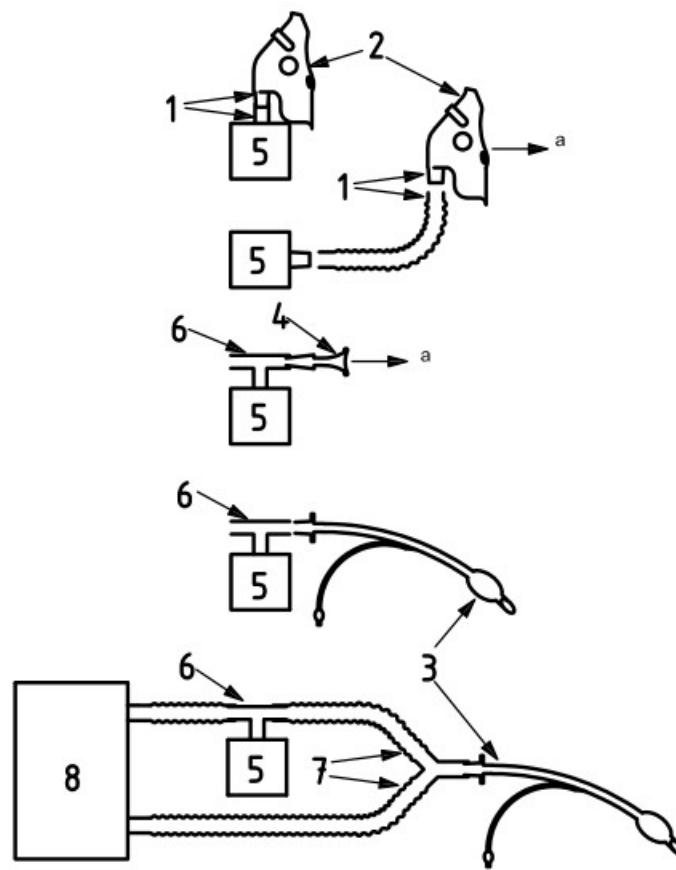

Key

- 1 ISO conical connectors (see ISO 5356-1 and ISO 5367)
- 2 aerosol mask, vented
- 3 tracheal tube (see ISO 5361)
- 4 mouthpiece
- 5 **nebulizer**
- 6 T-piece
- 7 ventilator breathing circuit
- 8 ventilator
- a To the patient.

Figure 2 — Examples of breathing system connectors for nebulizer systems

6.2.3 Flow direction-sensitive connectors

Any flow direction-sensitive, operator-detachable component shall be designed so that it cannot be fitted in such a way as to present a hazard to the patient.

6.3 Rotary controls

The manufacturer should ensure consistency regarding the direction of movement of rotary controls of the equipment.

7 Cleaning, sterilization, and disinfection

7.1 If provided sterile, the **nebulizing system** and components shall have been sterilized using an appropriate, validated method described in ISO 11135-1, ISO 11137-1, ISO 11137-2, ISO 11137-3, ISO 17665-1, or EN 556-1.

7.2 If provided sterile, the **nebulizing system** and components shall be contained in an individual pack marked as "STERILE". The pack shall serve as an effective barrier to the penetration of microorganisms and particulate material, in accordance with ISO 11607-1. The pack shall permit the aseptic extraction of the contents and shall not be capable of re-closure without clearly revealing that it has been opened.

7.3 Nebulizing systems and components intended for reuse shall be constructed so as to enable dismantling for cleaning and disinfection or sterilization.

NOTE See also ISO 17664,[\[17\]](#)

8 Biocompatibility

8.1 *Parts of the **nebulizing system** intended to come into contact with biological tissues, cells, body fluids, or breathing gases shall be assessed and documented according to the guidance and principles given in ISO 10993-1.

8.2 All parts of the **nebulizer** shall be designed and manufactured to minimize health risks due to substances emitted from the device during use.

Compliance is checked by inspecting the relevant **validation** reports (11.7 of IEC 60601-1:2005 applies).

Annex A (informative)

Rationale

General

This annex provides a concise rationale for the important requirements of this International Standard and is intended for use by those who are familiar with the subject of this International Standard but who have not participated in its development. An understanding of the reasons for the main requirements is considered essential for its proper application. Furthermore, as clinical practices and technologies change, it is believed that rationales for the present requirements will facilitate any revisions of this International Standard necessitated by those developments.

The clauses in this annex have been so numbered to correspond to the clauses in this International Standard to which they refer. The numbering is, therefore, not consecutive.

Clause 1 – Scope

The essence of this International Standard is to describe the characteristics and requirements of a general purpose **nebulizer** that can be used with a variety of medicinal substances. It is expected that the selection of the **nebulizer** will be based on the requirements and characteristics developed in this International Standard and declared in the manufacturer's instructions for use.

Nasal deposition devices are excluded, as they are not considered general purpose **nebulizers**.

There can be times when a device falls under the scope of either ISO 27427 or ISO 20072.^[18] The committee envisioned that the intended use of the product and the risk assessment of the device will determine which standard the manufacturer chooses to qualify the device.

General purpose nebulizers are considered to be semi-critical devices. Semi-critical devices are devices that contact intact mucous membranes or non-intact skin. They do not ordinarily penetrate tissues or otherwise enter normally sterile areas of the body. These devices should be reprocessed to be free from all microorganisms. However, intact mucosal surfaces are relatively resistant to small numbers of spores.

Subclause 3.3 – Aerosol output

Mass is directly traceable to the active ingredient which is the fundamental deliverable. Volume is a secondary measure because it is dependent on evaporation (see A.4).

Subclause 3.4 – Aerosol output rate

The **aerosol output rate** can be greatly influenced by the evaporation of the **aerosol** droplets. The following is provided to explain the sources and types of evaporation associated with nebulized **aerosol**:

Type 1 evaporation: Evaporation inside jet **nebulizers**. Compressed air (which is dry and on re-expansion to atmosphere is always dry) draws up and mixes with **nebulizer** reservoir solution sprayed within the **nebulizer**. The residence time of the de-compressed air (flow e.g. 6 l/min or 0,1 l/s) within the **nebulizer** (internal volume, approximately 100 ml) is short (around 1/10 of a second). Even so, the massive wet surface area of **aerosol** and rapid evaporation of solvent to the decompressed air ensures that the air leaving the **nebulizer** is nearly saturated with water vapour (approximately 100 %). Further, because of the latent heat lost to evaporation, the **nebulizer** reservoir cools relative to its initial ambient temperature (from 20 °C to approximately 10 °C) and the **aerosol**-laden air leaves the **nebulizer** in this cooled state. In this cooled saturated air cloud, the nebulized **aerosol** is stable until it either mixes with ambient air (see Type 2 evaporation) or increases in temperature (see Type 3 evaporation).

Type 2 evaporation: Evaporation of nebulized **aerosol** solvent when mixed with ambient air. Nebulized **aerosol** leaving a jet or ultrasonic **nebulizer** exists in a cloud of 100 % relative humidity (RH) air. This **aerosol** cloud is relatively stable with regard to evaporation until it mixes with ambient air. Mixing is inherent in the design of constant output **nebulizers** where the nebulized **aerosol** is emitted into a T-piece where the patient's inhalation flow causes ambient air at lower humidity to be drawn into the T-piece. The ambient air mixes with the nebulized **aerosol**-laden air and temporarily reduces the relative humidity. The relative humidity quickly rises to 100 % by evaporation of water from the nebulized **aerosol**. This evaporation effectively occurs in milliseconds, or using another reference, this evaporation happens by the time the **aerosol** passes through the T-piece and tubing and exits from the **nebulizer** mouthpiece (or very shortly thereafter). Of course, this volume loss implies that the size distribution of the nebulized **aerosol** has shifted downwards. Further, this shift could not be constant, as smaller droplets have the propensity to evaporate more readily than larger ones, so the distribution shift is not homogenous. In any case, after the nebulized **aerosol** gives up solvent to re-saturate the air, the nebulized **aerosol** is again stable. It is important to note that this form of evaporation is a feature of constant output **nebulizers** and not "breath-enhanced **nebulizers**" whose design causes entrained ambient air to draw solvent vapour from the **nebulizer** reservoir. For constant output **nebulizers**, the drier the ambient air, the greater the effect of evaporation on the nebulized **aerosol**. Further, the lower the rate of **aerosol output** relative to the flow of ambient air, the greater the effect of this evaporation on the nebulized **aerosol**.

Type 3 evaporation: Evaporation of nebulized **aerosol** solvent within a cascade impactor. Nebulized **aerosol**, after mixing with ambient air, equilibrates to 100 % RH and is relatively stable. However, it is cool due to the latent heat of evaporation (e.g. 10 °C). The cool stable nebulized **aerosol** passes into a cascade impactor. If the cascade impactor is at ambient temperature (e.g. 20 °C), the cooled air is in contact with the cascade, which can act like a kind of radiator warming up the nebulized **aerosol**-laden air. As the air warms up and travels through the cascade, the capacity of the warmer air to hold moisture increases. In order to maintain 100 % RH, further evaporation occurs from the nebulized **aerosol** during its flight through the cascade. As with the type 2 evaporation, the smaller the size of the particles in the nebulized **aerosol**, the more significant the losses and the greater the size change.^[31]

Subclause 3.15 – Percentage of fill volume emitted

The **percentage of fill volume emitted** is an important value to be disclosed to the user, because it can influence the decisions of dosage intended for delivery in terms related to the expected amount of drug given to the patient.

The **percentage of fill volume emitted** per minute, when expressed as a rate, is an important value to disclose to the user, because it can influence the decisions of dosage intended for delivery in terms related to the expected duration of the therapy.

Subclause 3.16 – Residual volume

The **residual volume** is an important value to disclose to the user, because it can influence the decisions on the dosage intended for delivery.

Subclause 3.17 – Respirable fraction

The **respirable fraction**, as defined in 3.17, was harmonized with the European, Pharmacopeia Chapter 2.9.18.^[34] The **respirable fraction** is an important parameter because, along with the **aerosol output**, it gives a single physical characteristic that allows the comparison of the performance of **nebulizing systems**.

Subclause 3.18 – Test solution

The **test solution**, as defined in 3.18, is used throughout the type-test requirements and Annex test methods to allow flexibility, if permitted by a local competent authority, in the use of alternative aqueous solution media to characterize **nebulizer** performance. Some of the alternative aqueous solutions cost less and can be analysed using simpler means (e.g. electrochemistry, conductivity, etc.).

Subclause 4.2.1.1 – Type-test methods, representative samples

The subcommittee believes that testing to validate clinical performance that characterizes the intersample and intrasample variability in terms of particle specifications would also be beneficial. See 6.1 in ISO 20072:2009.[18]

Subclause 4.2.1.2 – Type-test solutions

Use sodium fluoride rather than albuterol as the test substance is considered to provide comparable outcomes. Albuterol (also known as salbutamol) can be difficult to obtain in some countries.

US FDA 1993 guidance states:

3. Testing should be conducted on drugs from three of the following drug classes: beta-agonist bronchodilators, anticholinergic bronchodilators, steroids, antiallergics, mucokinetic agents, and anti-inflammatories. While other drugs can be appropriate, we suggest testing with ipatropium bromide (anti-cholinergic bronchodilator), albuterol (beta-agonist bronchodilator) and cromolyn sodium (anti-inflammatory).[40]

Subclause 4.2.2 – Alternative test methods

Various methods for presenting the particle size distribution of **nebulizers** are in use (see [Annex B](#)).

Various methods for presenting the **aerosol output** are in use.

Subclause 5.4 – Instruction for use

See also Reference.[28]

Subclause 5.4.1 g) – Maximum temperature of the nebulizing chamber

Disclosure of the maximum temperature of the nebulizing chamber is important because certain active ingredients, such as nebulized proteins or DNA components, can be sensitive to temperature and degrade within the **nebulizer** chamber.[37]

Subclause 5.4.2 k) – Alternative test methods

Alternative test methods, such as laser diffractometry, electrochemistry,[32] high-performance liquid chromatography (HPLC), or spectrophotometry,[38] can be used for the repeated performance assessment, once these methods have been validated against the cascade impaction method during the initial testing.

Subclause 5.4.2 m) – Sound pressure levels

See also information and alternative test methods in References[1] and.[24]

Subclause 6.2.1 d) – Small bore connectors

Small bore connectors that comply with ISO 80369-1 are designed to reduce the risk associated with misconnection with connectors for other applications, such as respiratory, enteral, limb-cuff inflation, neuraxial, and intravascular and hypodermic applications. ISO 80369-2 (under development)[25] describes male and female connectors designed for breathing gas supply applications. When ISO 80369-2 is published, it is expected that the nipples and end connectors described in EN 13544-2 will be replaced by an ISO 80369-2 small bore connector suitable for all therapeutic administration of respirable gases in domiciliary, ambulance, and healthcare practice, including the interface to the equipment (i.e. for connectors on the tubing mainly used to deliver oxygen, air, or mixtures of these gases).

Subclause 8.1 – Biocompatibility

Devices that contact the patient gas pathway (e.g. nebulizers) are considered to be externally communicating devices with tissue contact due to the potential for chemical leachants from the device entering the patient's airway. Appropriate biocompatibility tests should be selected in accordance with ISO 10993-1 with consideration of the cumulative duration of contact of the device.

Annex C, Subclause C.1 – Test principle

A treatment session using a **nebulizer** requires the patient to breathe in and out of the **nebulizer** for a duration of approximately 5 min to 15 min (depending on the medication used) while the **nebulizer** is running. During this time, the **nebulizer** is continuously producing **aerosol**. When the patient inhales **aerosol**, it is taken up in the lungs. However, when the patient exhales, some **aerosol** is driven out of the **nebulizer** and lost. Thus, only a certain fraction of **aerosol** produced by the **nebulizer** can be taken up by the patient. The test described in this Clause collects the **aerosol** exiting at the **nebulizer** mouthpiece while the **nebulizer** is subjected to a simulated breathing pattern. The mass of the collected albuterol is extracted and measured. The volume of **aerosol** delivered is calculated and expressed as **aerosol output rate** in millilitres of **test solution** 0,1 % (M/V) per minute.

[Annex C, Subclause C.2](#) – Test conditions

The committee chose these conditions to represent the conditions affecting the majority of general **nebulizers** used in home care and cannot represent the use of **nebulizers** within breathing systems, where higher temperatures, pressures, and humidity can affect the **nebulizer** performance.

[Annex C, Subclause C.3](#) – Test equipment

A breathing simulator is used when determining the **aerosol output** from a **nebulizer** in order to reasonably estimate the mass of aerosolized active pharmaceutical ingredient provided at the outlet of the **nebulizing system** under simulated conditions of breathing. For nebulizers intended for use over wide patient populations, it could be useful to analyse multiple breathing patterns associated with different patient populations.^[33]

[Annex C, Subclause C.4](#) – Test method

Measurements of mass (weight) rather than volume alone correct for evaporative losses.

[Annex D, Subclause D.1](#) – Test principle

A continuous suction pump is used for nebulized **aerosol** size testing because impactors for performing these measurements need to operate at a constant “inhalation” flow rate to reasonably estimate **aerosol** size.

Annex B (normative)

Diameters of respirable fraction particles

In general, it is considered that **aerosol** particles with an aerodynamic diameter of

- >5 µm results in deposition in the upper airways,
- 2 µm to 5 µm results in deposition in the lower airways, and
- <2 µm results in deposition in the alveoli.^{[35][39]}

Aerosol particle sizing can be defined in terms of **mass median aerodynamic diameter (MMAD)** and geometric standard deviation (GSD). These values can be interpolated from the cumulative particle size distribution curve as follows.

MMAD: Note the particle size at which the line crosses the 50 % mark.

GSD: This should be calculated only if the particle size distribution curve is reasonably straight between 10 % and 90 %, showing that the **aerosol** is log-normally distributed. Where a straight line is a good fit to the data, the calculation of GSD is performed by noting the particle size X at which the line crosses the 84,13 % mark and the particle size Y at which the line crosses the 15,87 % mark.

Then, the $GSD = (X/Y)^{0,5}$.

Methods of deriving information from data that are based on interpolation from a graph are inevitably subject to some degree of approximation.

Rigorous mathematical methods of analysis are described in References [4] and [5]. These methods are readily performed by a computer, including the generation of the particle size distribution graph.

Annex C (normative)

Test methods for aerosol output and aerosol output rate

C.1 *Test principle

The **nebulizer** is filled with the required volume of **test solution**, connected to a breathing simulator (e.g. a sine-wave pump or volumetric ventilator that creates a sinusoidal waveform) to simulate respiratory flow (see [Figure C.1](#)). During operation of the **nebulizer**, the **aerosol** emitted at the patient interface is collected on a filter. This filter can be extracted to analyse the mass of the collected test substance using an appropriately validated analytical method [high-performance liquid chromatography (HPLC), UV-spectroscopy, gravimetric or electrochemical analysis, or other].^{[30][31][32][38]}

During the experiment, the nebulization is conducted for a known time (e.g. 1 min), after which the filter is exchanged and analysed. Dividing the mass of test substance by this time gives the **aerosol output rate**.

The experiment is then continued to collect the total mass of test substance emitted at the aerosol outlet port. Collection filters can be replaced several times to avoid saturation of the filter. At the end of the nebulization, the **aerosol output** is determined by adding up the results from all collection filters.

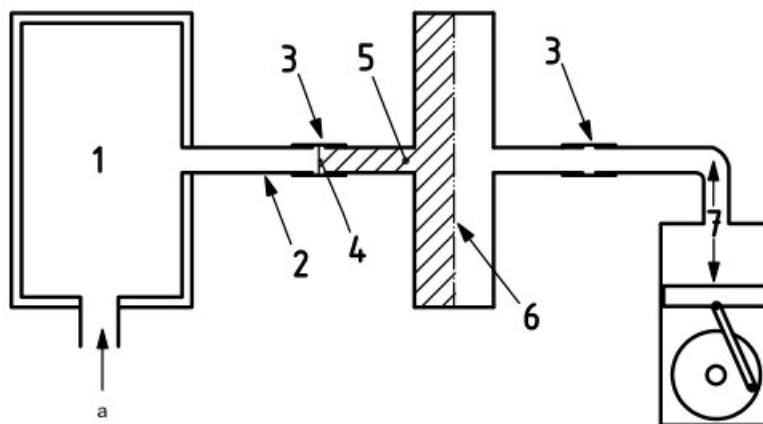

Key

- 1 **nebulizing system** filled with **test solution** and (if required) an inlet for entrained ambient air or exhaust gases
- 2 connection to the **aerosol outlet port**
- 3 dismountable connectors
- 4 **aerosol outlet port**
- 5 dead space
- 6 collection filter
- 7 breathing simulator
- a Inlet for driving gas.

Figure C.1 — Schematic diagram showing the equipment for testing the aerosol output and aerosol output rate

C.2 *Test conditions

The ambient test conditions shall be:

- temperature: (23 ± 2) °C;
- relative humidity: 45 % to 75 %;
- pressure: from 86,0 kPa to 106,0 kPa (i.e. absolute atmospheric pressure).

C.3 *Test equipment

The test equipment (see the schematic diagram in [Figure C.1](#)) shall comprise:

- the **nebulizing system** under test;

NOTE 1 The **nebulizing system** under test can be connected to a patient interface component (e.g. a mouthpiece or facemask). The dismantable connector (3 in [Figure C.1](#)), at the inlet to the filter holder, provides a matching adaptor to make a leak-free joint.

- a **test solution** of albuterol 0,1 % (M/V) concentration in 0,9 % sodium chloride solution or, if allowed or required by local competent authorities, 2,5 % (M/V) sodium fluoride in distilled water, with the provision that its use is declared in the accompanying documents [see [5.4.2 k](#)];
- a filter holder;
- a breathing system filter complying with ISO 23328-1 with a filtration efficiency of >98 % of particles less than 10 µm;

NOTE 2 Suitable filters are high-efficiency polypropylene filters (product K248 of 3M).¹⁾

- *a breathing simulator (e.g. a sine-wave pump or volumetric ventilator that creates a sinusoidal waveform to simulate respiratory flow), which creates a cycle of frequency, f = 15 breaths/min; I/E ratio = 1:1; and tidal volume (V_t) = 500 ml measured at the outlet of the filter;
- a dead space (between the **aerosol outlet port** and the filtering surface) of 10 % or less of the tidal volume;
- for **gas-powered nebulizers**, a driving gas of medical air as defined in ISO 7396-1, unless the **nebulizer** is designed to be powered exclusively by a compressor, at ambient conditions described in [C.2](#), and driven by the gas at the flow rate recommended by the manufacturer;
- a means of extracting the test substance from filters and other components and quantitative analysis apparatus calibrated to an accuracy of ± 5 % of reading.

NOTE 3 The quantitative analysis apparatus is validated and can include high-performance liquid chromatography (HPLC), UV spectroscopy, gravimetric, or electrochemical analysers.^{[30][32][38]}

C.4 *Test method

- a) Pre-weigh the **nebulizing system** before filling with the **test solution**.
- b) Stabilize all parts of the **nebulizer system**, fluids, and test equipment at the ambient conditions, as described in [C.2](#), before use.
- c) Perform the test with the **nebulizer** filled with **test solution** to the fill volume recommended by the manufacturer or 2 ml if no fill volume is recommended.

1) This information is given for the convenience of users of this document and does not constitute an endorsement by ISO TC 121/SC 2 of the product named. Equivalent products may be used if they can be shown to lead to the same results.

ISO 27427:2013(E)

- d) By means of dismountable connectors, connect the outlet of the **nebulizing system** to the filter and its holder, and the latter to the breathing simulator (sine pump), as shown in [Figure C.1](#).
- e) Switch on the breathing simulator and, 10 s later, the **nebulizer**.
- f) Run the **nebulizer** for (60 ± 1) s, switch off the **nebulizer** and, 5 s later, the pump.
- g) Dismantle the filter, the filter holder, and the dismountable connectors from the outlet of the **nebulizing system** to the filter holder.
- h) *Extract and measure the mass of test substance in the components downstream of the outlet of the **nebulizer**, including the filter, and use this result to calculate the **aerosol output rate**.
- i) Assemble a new filter and its holder and continue the experiment until the end of nebulization to measure the total **aerosol output**. The end of nebulization, for **gas-powered nebulizers**, is 1 min after the beginning of sputtering, and for **electronic nebulizers**, the end of the operation, as defined by the manufacturer.
- j) Stop the nebulization and re-weigh the **nebulizing system**.
- k) **Residual volume** is calculated by subtracting the initial dry weight from the final weight of the **nebulizing system** and multiplying this mass by the specific gravity of the **test solution**.
- l) All type-test methods shall be performed on at least three representative test devices. See [4.2.1.1](#).

C.5 Test results

The test results shall include:

- a) for a **gas-powered nebulizer**, the test gas employed;
- b) the **test solution**;
- c) the **filling volume** and flow rate used;
- d) the **aerosol output**, expressed as the mass of test substance collected on the filter(s);
- e) the **aerosol output rate**, expressed as the mass of test substance collected on the filter(s) per minute;
- f) nebulization time;
- g) **residual volume**;
- h) the **percentage of fill volume emitted** in 1 min, expressed as the **aerosol output** in 1 min divided by the fill volume recommended by the manufacturer or 2 ml if no fill volume is recommended (e.g. 20 % of fill volume per minute).

NOTE **Aerosol output** is directly measured as the mass of test substance by the test lab and can be converted to % of total mass loaded into the **nebulizer** for the disclosure of the results [see also [3.3](#) and [5.4.2](#) g)]. Likewise, **aerosol output rate** is directly measured as the mass of test substance per minute and can be converted to ml/min for disclosure, while **percentage of fill volume emitted** in 1 min or %/min expresses **aerosol output rate** as a percentage of the fill volume recommended by the manufacturer or 2 ml if no fill volume is recommended.

Annex D (normative)

Test methods for particle sizing

D.1 *Test principle

The **nebulizing system** is tested for particle size by capturing the **aerosol output** in a cascade impactor driven by air and by analysing the results.

Two different sets of test equipment and test methods are described that allow the use of either

- a high-flow cascade impactor (calibrated at 15 l/m), or
- a low-flow cascade impactor (calibrated at flows less than 15 l/m).

The two test methods differ in the use of a T-piece and/or air entrainment port that serves as a means to allow more gas to be emitted by the **nebulizer** than that which is drawn into the cascade impactor. Test conditions, calculations, and expressions of test results are otherwise identical between the two methods.

NOTE Several types of cascade impactors are available: Marple, Anderson, and Next Generation Impactor (NGI).²⁾

D.2 Test conditions for all test methods

The ambient test conditions for all tests shall be:

- temperature: (23 ± 2) °C;
- relative humidity: 45 % to 75 %;
- pressure: from 86,0 kPa to 106,0 kPa.

D.3 Test using a cascade impactor calibrated and operating at 15 l/min

D.3.1 Test equipment

The test equipment (see the schematic diagram in [Figure D.1](#)) shall comprise:

- a) the **nebulizing system** under test;
- b) a cascade impactor:
 - 1) with at least eight stages to estimate the **respirable fraction**;
 - 2) with sufficient loading capacity on each stage to estimate the **respirable fraction** without overloading any stage;
 - 3) with no measurable heat transfer-related droplet evaporation;

NOTE 1 The impactor can be chilled to avoid this cause of inaccuracy.

2) This information is given for the convenience of users of this document and does not constitute an endorsement by ISO TC 121/SC 2 of the product named. Equivalent products may be used if they can be shown to lead to the same results.

- 4) calibrated at a flow of 15 l/min, either by the manufacturer or the user, and specifying:
 - a D_{50} [the aerodynamic diameter of a particle having a 50 % probability of impacting on the collection stage, also called the effective cutoff diameter (ECD)];
 - a D_{84} (the aerodynamic diameter of a particle having an 84 % probability of impacting on the collection stage) that is less than $1,3 \times D_{50}$;
 - a D_{16} (the aerodynamic diameter of a particle having a 16 % probability of impacting on the collection stage) that is greater than $0,77 \times D_{50}$;

NOTE 2 Selection of the cut points (i.e. D_{50}) for the impactor includes at least two stages with D_{50} s greater than the **MMAD** of the **aerosol** from the **nebulizer** and two stages with D_{50} s less than the **MMAD** of the **aerosol** from the **nebulizer**.

- c) a sampling pump and adjustable flowmeter capable of drawing air through the cascade impactor at a flow of 15 l/min;
- d) a **test solution** (at stabilized temperature) of albuterol 0,1 % (M/V) concentration in 0,9 % sodium chloride solution or, if allowed or required by local competent authorities, 2,5 % (M/V) sodium fluoride in distilled water, with the provision that its use is declared in the accompanying documents. See 5.4.2 k);
- e) for **gas-powered nebulizers**, a driving gas of medical air as defined in ISO 7396-1, unless the **nebulizer** is designed to be powered exclusively by a compressor, at ambient conditions described in C.2, and driven by the gas at the flow rate recommended by the manufacturer.

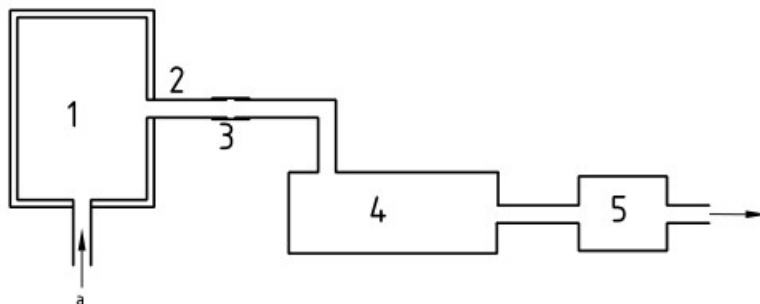

Key

- 1 **nebulizing system** filled with **test solution** with an entrained ambient air inlet (i.e. T-piece), if required
- 2 **aerosol outlet port**
- 3 dismountable connector
- 4 cascade impactor
- 5 sampling pump
- a Inlet for driving gas.

Figure D.1 — Schematic diagram showing the equipment for testing the particle sizes

D.3.2 Test method

D.3.2.1 The **nebulizer** is filled with the **test solution** to the fill volume recommended by the manufacturer or 2 ml if no fill volume is recommended and connected to the test compressor or air supply in accordance with the manufacturer’s instructions.

D.3.2.2 The cascade impactor is dismantled, cleaned (e.g. with distilled water, wiped and allowed to air dry), and reassembled, incorporating all the stages of impaction surfaces in accordance with the manufacturer’s instructions.

D.3.2.3 Readily dismantlable connectors are attached between the **nebulizer aerosol outlet port** and the inlet of the connector attached to the cascade impactor.

D.3.2.4 If required, an absolute filter is connected between the outlet of the cascade impactor (4 in [Figure D.1](#)) and the sampling pump (5 in [Figure D.1](#)), to prevent fine **aerosol** droplets from entering the sampling pump.

D.3.2.5 The flow of the sampling pump is set to $(15 \pm 5) \%$ l/min.

NOTE 1 During testing, the **nebulizer** and the cascade impactor are secured in the position specified by the manufacturer.

NOTE 2 Care should be taken to prevent vibration of the impactor and to minimize perturbation of flow through the test apparatus.

D.3.2.6 The sampling pump is turned on and allowed to stabilize at the required flow.

D.3.2.7 The **nebulizer** is started.

D.3.2.8 Sampling times can be varied for different **nebulizers** to allow for maximum deposition on each stage without overloading the stages.

NOTE Some experimentation could be needed to establish the optimum period of test, aided by visual recognition of "overloading" an impactor substrate.

D.3.2.9 After sampling for the required time, the **nebulizer** is switched off, followed in a few seconds by the sampling pump.

D.3.2.10 The cascade impactor is dismantled from the remainder of the apparatus.

D.3.2.11 The impactor is dismantled according to the manufacturer's instructions and the mass of **test solution** on the individual stages of the impactor, the input connection, and the outlet filter is determined (see also [4.2.3](#)).

D.3.2.12 All type-test methods shall be performed on at least three representative test devices. See [4.2.1.1](#).

D.4 Test using a cascade impactor calibrated and operating at less than 15 l/min

D.4.1 Test equipment

The test equipment (see the schematic diagram in [Figure D.2](#)) shall comprise:

- a) the **nebulizing system** under test containing, if required, an entrained ambient air inlet (i.e. T-piece) to allow more gas to be emitted by the **nebulizer** than that which is drawn into the cascade impactor;
- b) a cascade impactor:
 - 1) with at least eight stages to estimate the **respirable fraction**;
 - 2) with sufficient loading capacity on each stage to estimate the respirable fraction without overloading stages;
 - 3) with no measurable heat transfer-related droplet evaporation;

NOTE 1 The impactor can be chilled to avoid this cause of inaccuracy.

ISO 27427:2013(E)

4) calibrated at a flow not exceeding 15 l/min, either by the manufacturer or the user, and specifying:

— a D_{50} (the aerodynamic diameter of a particle having a 50 % probability of impacting on the collection stage, also called the ECD);

— a D_{84} (the aerodynamic diameter of a particle having an 84 % probability of impacting on the collection stage) that is less than $1,3 \times D_{50}$;

— a D_{16} (the aerodynamic diameter of a particle having a 16 % probability of impacting on the collection stage) that is greater than $0,77 \times D_{50}$;

NOTE 2 Selection of the cut points (i.e. D_{50}) for the impactor includes at least two stages with D_{50} s greater than the **MMAD** of the aerosol from the **nebulizer** and two stages with D_{50} s less than the **MMAD** of the **aerosol** from the **nebulizer**.

c) a 22 mm T-piece connected to the inlet of the cascade impactor using a connector with a 22 mm internal diameter;

d) a sampling pump and adjustable flowmeter capable of drawing through the cascade impactor a flow specified in the calibration data of the cascade impactor;

e) a collection filter complying with ISO 23328-1 with a filtration efficiency of >98 % of particles less than 10 μm and having minimal resistance connected to the T-piece to capture excess **aerosols**;

NOTE 3 Suitable filters are high-efficiency polypropylene filters (product K248 of 3M).³⁾

f) a suction pump that creates a continuous flow sufficient to raise the total flow through the T-piece ([Figure D.2](#), item 6) to $15 \text{ l/min} \pm 1,5 \text{ l/min}$, the surplus flow above the sampling flow to the cascade impactor passing through the collection filter;

NOTE 4 This pump is not required if the cascade impactor is calibrated at 15 l/min.

g) the **test solution** (at stabilized temperature) of albuterol 0,1 % (M/V) concentration in 0,9 % sodium chloride solution or, if allowed or required by local competent authorities, 2,5 % (M/V) sodium fluoride in distilled water, with the provision that its use is declared in the accompanying documents. See [5.4.2 k](#));

h) for **gas-powered nebulizers**, the driving gas specified by the manufacturer (either compressed air from ambient conditions as described in C.1.1 or medical air as defined in ISO 7396-1).

3) This information is given for the convenience of users of this document and does not constitute an endorsement by ISO TC 121/SC 2 of the product named. Equivalent products may be used if they can be shown to lead to the same results.

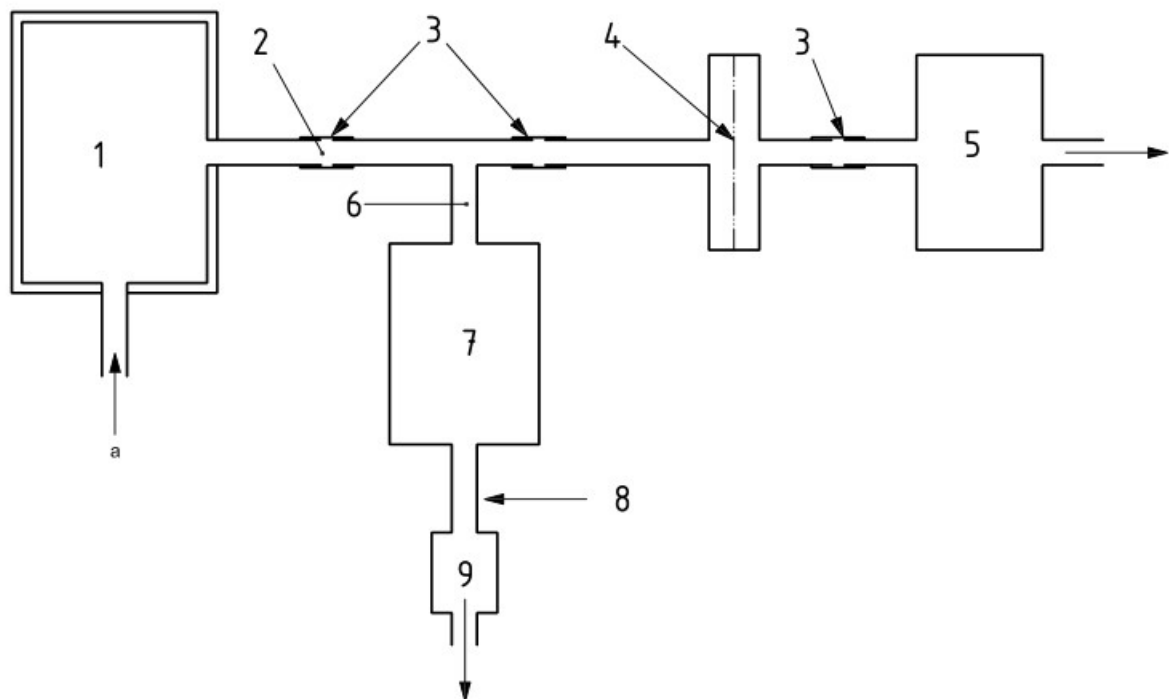

Key

- 1 **nebulizing system** filled with **test solution** with an entrained ambient air inlet (i.e. T-piece), if required
- 2 **aerosol outlet port**
- 3 dismountable connectors
- 4 collection filter for excess aerosol
- 5 suction pump
- 6 T-piece
- 7 cascade impactor
- 8 connector to sampling pump
- 9 sampling pump
- a Inlet for driving gas.

Figure D.2 — Schematic diagram showing the equipment for testing the particle sizes

D.4.2 Test method

D.4.2.1 The **nebulizer** is filled with the **test solution** to the fill volume recommended by the manufacturer or 2 ml if no fill volume is recommended and connected to the test compressor or air supply in accordance with the manufacturer's instructions.

D.4.2.2 A T-piece is attached to the **nebulizer** chamber outlet.

D.4.2.3 The cascade impactor is dismantled, cleaned (e.g. with distilled water, wiped and allowed to air dry), and reassembled, incorporating all the stages of impaction surfaces in accordance with the manufacturer's instructions.

D.4.2.4 Readily dismountable connections are made from the T-piece to the inlet of the connector attached to the cascade impactor and from the outlet of this connector to the collection filter, which is connected to a suction pump.

ISO 27427:2013(E)

D.4.2.5 An absolute filter (see [D.3.2.4](#)) is interposed between the outlet of the cascade impactor and the sampling pump, the flow of which is set to the calibration flow of the cascade impactor (e.g. 2 l/min ± 10 %.)

NOTE 1 During testing, the **nebulizer** and the cascade impactor are secured in the position specified by the manufacturer.

NOTE 2 Care should be taken to prevent vibration of the impactor and to minimize perturbation of flow through the test **apparatus**.

D.4.2.6 The suction and sampling pumps are turned on and allowed to stabilize at the required flows.

NOTE The flow rate of the suction pump is adjusted in such a way that a total flow of 15 ml/min is drawn through the **nebulizer**, while at the same time, the sampling pump draws the flow rate which is required to operate the impactor (e.g. the suction pump for the excess **aerosol** is adjusted to produce an exhaust flow of 13 l/min ± 10 % and the cascade impactor sampling pump is adjusted to the calibration flow of 2 l/min ± 10 %).

D.4.2.7 The **nebulizer** is started.

D.4.2.8 Sampling times can be varied for different **nebulizers** to allow for maximum deposit on each stage without overloading the stages.

NOTE Some experimentation might be needed to establish the optimum period of test, aided by visual recognition of "overload" of an impactor substrate.

D.4.2.9 After sampling for the required time, the **nebulizer** is switched off, followed in a few seconds by the sampling pump and then the suction pump.

D.4.2.10 The cascade impactor is dismantled from the remainder of the apparatus.

D.4.2.11 The impactor is dismantled according to the manufacturer's instructions and the mass of **test solution** on the individual stages of the impactor, the input connection, and the outlet filter determined.

D.4.2.12 All type-test methods shall be performed on at least three representative test devices. See [4.2.1.1](#).

D.5 Test results

D.5.1 Calculations

Use of appropriate software to calculate and draw all the results is allowed.

a) Calculate the total mass of albuterol collected in the impactor as follows in the case of eight stages:

$$F = m_1 \text{ (including inlet assembly)} + m_2 + m_3 + m_4 + m_5 + m_6 + m_7 + m_8 + m_{\text{filter}} \quad (\text{D.1})$$

- b) Calculate the cumulative collection (%) of albuterol of particle mass under size as follows.

$$c_8 = m_{\text{filter}}/F \cdot 100 \quad (\text{D.2})$$

Plot this against the D_{50} of stage 8.

$$c_7 = c_8 + m_8/F \cdot 100 \quad (\text{D.3})$$

Plot this against the D_{50} of stage 7.

$$c_6 = c_7 + m_7/F \cdot 100 \quad (\text{D.4})$$

Plot this against the D_{50} of stage 6, and so forth,

where

F is the total mass of albuterol collected in the impactor, including the inlet assembly and the filter;

m_x is the mass collected on stage x ;

c_x is the cumulative collection in percent of particle undersize.

NOTE A typical set of figures is shown in [Table D.1](#), which includes mean values from the series of tests.

- c) Plot the cumulative size distribution on log-probability graph paper, as shown in [Figure D.3](#). The utility of the log-probability graph is that the cumulative size distribution can be represented by a straight line fitted through the data points. This is equivalent to the more familiar "S" curve fitted to the data on semi-log graph paper. The probability axis is a linear scale of the "z" values (standard deviation units associated with the cumulative area under a normal distribution). An Excel spreadsheet can be used to plot this rather than using log-probability paper by converting the cumulative frequency to z values using the NORMSINV function and plotting the results on a linear axis and the diameter values on a logarithmic axis.
- d) Determine the **MMAD** and the GSD as illustrated in [Figure D.3](#).

The **MMAD** is the diameter vertically below the horizontal intersection of the 50 % cumulative frequency value and the size distribution line. The GSD shall be calculated using the values $D(-1)$ or $D(1)$. The diameter $D(-1)$ is the diameter vertically below the horizontal intersection of the 16 % cumulative frequency value (or the value -1 on the probability axis) and the size distribution line; alternatively, the $D(1)$ value [the diameter vertically below the horizontal intersection of the 84 % cumulative frequency value (or the value 1 on the probability axis) and the size distribution line].

The GSD is then the $\text{MMAD}/D(-1)$ or $D(1)/\text{MMAD}$.

It is not necessary to plot all the results from the impactor stages to determine the **MMAD** of the **nebulizer**. It is only necessary to plot the two values, one above and one below the 50 % cumulative collection efficiency value, to find the **MMAD** and plot the line representing the size distribution. Plotting more points than that could result in the value being determined with less accuracy. Points farther away from the 50 % cumulative value have less accuracy because they represent a smaller fraction of the total mass. Points closer to the **MMAD** will have higher mass and should be determined therefore with greater accuracy. By weighting points with less accuracy with the same weighting as points with more accuracy (i.e. by drawing a best fit line through all the points), the overall accuracy of the determination is reduced. Using only the points representing the highest mass (i.e. those above and below the **MMAD**) to draw the line ensures higher accuracy even though only two points are used.

D.5.2 Expression of test results

The test results shall include

- for **gas-powered nebulizers**, the test gas employed,
- the filling volumes and flow rates used, and
- the mass of **test solution** deposited on the individual stages of the impactor (including the inlet assembly and the absolute filter).

Table D.1 — Typical sets of results from repeat measurement of a cascade impactor

Stage no.	Effective cut-off diameter µm	Cumulative particle mass of albuterol under size %				
		Mean	Test 1	Test 2	Test 3	Test 4
8	0,53	2,1	2,8	3,2	1,5	1,1
7	0,93	5,2	5,6	6,4	5,4	3,4
6	1,6	14,0	13,7	17,0	13,3	12,1
5	3,5	43,6	41,4	47,0	42,9	43,1
4	6,0	72,0	69,6	73,2	70,0	75,3
3	9,8	87,4	85,0	87,4	85,2	92,0
2	14,8	94,1	93,0	94,1	92,1	97,1
1	21,3	96,2	95,4	96,0	95,6	97,7

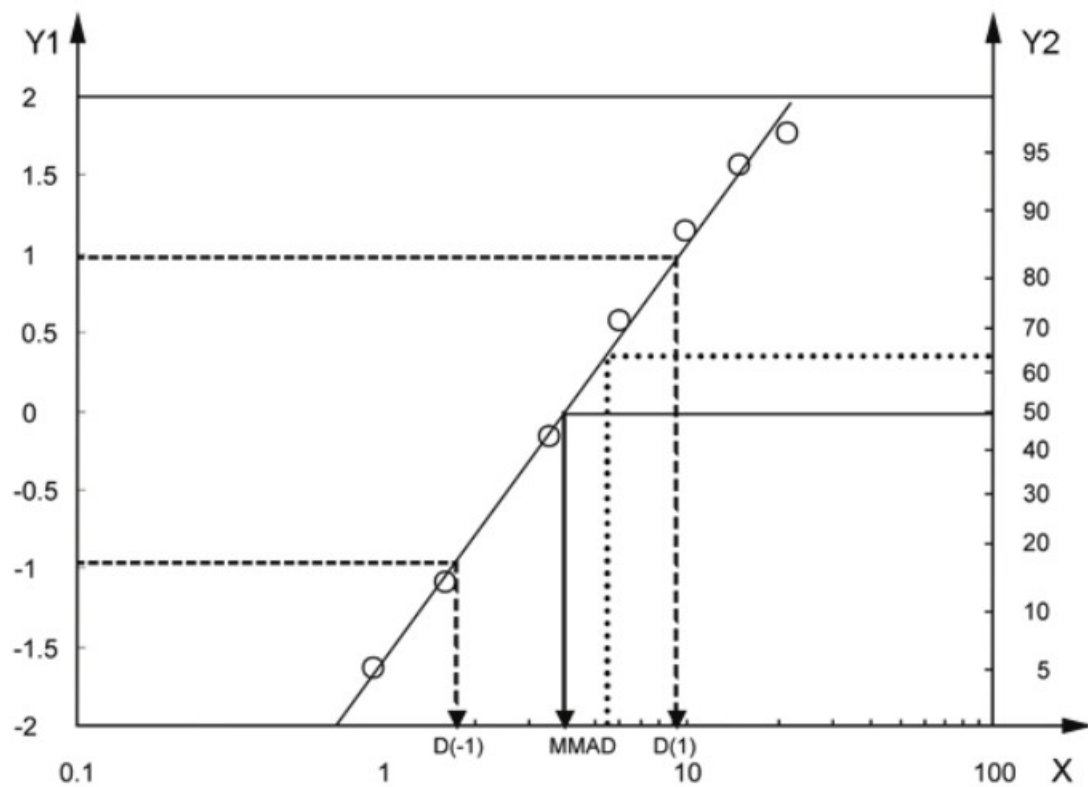

Key

- X diameter (μm)
- Y1 probability (z values)
- Y2 cumulative percent
- solid line **MMAD** (3,9 μm)
- dashed line $MMAD/D(-1) = GSD$ or $D(1)/MMAD = GSD$ (2,06)
- dotted line cumulative % less than 5 μm (60 %)

NOTE Parameters such as the **MMAD** of 3,9 μm (shown with an arrow) and percent **aerosol** solute mass below 5 μm (in this case approximately 60 %) can be interpolated from the plot.

Figure D.3 — Example plot of cumulative size distribution from results in [Table D.1](#)

Annex E (informative)

Hazard identification for risk assessment

NOTE This list is not intended to be comprehensive for all devices within the scope of this International Standard, but it provides guidance for risk assessment. Not all hazards apply to each type of **nebulizer**.

E.1 Potential adverse events associated with the use of nebulizers or nebulizer systems

The following injuries are based on the Adverse Event Reports submitted to the United States Food and Drug Administration (FDA) CDRH Manufacturers and Users Device Experience (MAUDE) Database for Product Code CAF (**nebulizers**) during the period of 1996-08-01 to 2007-04-27. The database includes 122 reports, 3 deaths, and 10 injuries.

- a) Trauma (mechanical, neurovascular, or cardiopulmonary injury related to inhalation of **nebulizer** fragments or components, fire, and/or electrical shock) causing:
 - 1) soreness, minor abrasions;
 - 2) haematoma;
 - 3) dermal ischemia;
 - 4) necrosis;
 - 5) epiglottic entrapment or inflammation;
 - 6) upper oesophageal sphincter injury;
 - 7) tissue damage, oedema;
 - 8) severe or prolonged sore throat;
 - 9) neuropathy;
 - 10) vocal cord damage;
 - 11) dental damage;
 - 12) bleeding;
 - 13) infection;
 - 14) adult respiratory distress syndrome (ARDS) associated with smoke inhalation injury;
 - 15) dermal burns;
 - 16) thermal airway burns;
 - 17) barotrauma, volutrauma, stretch injury;
 - 18) hyperthermia, hypothermia;

- 19) overhydration.
- b) Inadequate ventilation (hypoxia, hypercarbia) due to:
- 1) leakage of respiratory gases;
 - 2) inadequate oxygen flow;
 - 3) low oxygen concentration;
 - 4) airway obstruction;
 - 5) inadequate spontaneous ventilation;
 - 6) reactive airways disease;
 - 7) bronchospasm, laryngospasm, stridor, hiccup, coughing, breath holding;
 - 8) negative pressure pulmonary oedema;
 - 9) rebreathing;
 - 10) increased intrathoracic pressure;
 - 11) thickened secretions, mucus plugs.
- c) Aspiration or regurgitation due to:
- 1) aspiration of bulk **nebulizer** solutions, water, or saline;
 - 2) inadequate attachment to or locking of the tracheal tube or other airway device;
 - 3) gastric insufflations;
 - 4) inability to evacuate gastric contents;
 - 5) airway obstruction (kinking or narrowing) with spontaneous breathing.
- d) Toxicity:
- 1) allergy, including latex;
 - 2) smoke inhalation injury;
 - 3) oxygen toxicity;
 - 4) inhalation of cleaning and/or disinfection solutions;
 - 5) radiation toxicity [due to excessive technetium 99m-labelled diethylenetriamine penta-acetic acid (^{99m}Tc-DTPA) **aerosol** administration/contamination].
- e) Pharmacologic injury due to excessive/inadequate **aerosol** delivery:
- 1) tachycardia;
 - 2) bradycardia;
 - 3) cardiopulmonary failure;
 - 4) hypertension/hypotension;
 - 5) hypervolemia;
 - 6) unconsciousness;
 - 7) death.

E.2 Potential nebulizer device hazards identified by the FDA MAUDE database

E.2.1 Summary

Potential hazards are as follows:

- a) Fire:
 - 1) overheating;
 - 2) electrical malfunction, short circuits, sparks.
- b) Fragmentation:
 - 1) broken components;
 - 2) detached components.
- c) Inadequate oxygen:
 - 1) damaged air entrainment dial;
 - 2) damaged oxygen connector.
- d) Misconnection:
 - 1) **nebulizer** connected directly to a tracheal tube;
 - 2) **nebulizer** connected to the wrong port of a ventilator.
- e) Low **aerosol output**:
 - 1) missing components;
 - 2) damaged components;
 - 3) electrical failure.

E.2.2 MAUDE Report Details

CAUSE	REPORT
Burns	Contact dermal burns caused by laying compressor against the thigh (2 reports) Overheated tubing (44 °C), hot to touch
Contamination	Blood inside nebulizer in sealed package (2 reports) Bleach odour from nebulizer , albuterol turned yellow colour
Electrical hazard	Battery failure, no aerosol , no therapy Connection cable pulls free, disconnects easily Electrical shock Cables break at connector Electrical shorting, electrocution Cracked power adaptor, exposed wires
Fire	Smoke/fire, overheating/melting (28 reports)

CAUSE	REPORT
Fragments	<p>T-piece obstruction</p> <p>Cracked nebulizer, non-functional</p> <p>Mouthpiece rubber flap disconnected, potential airway obstruction</p> <p>Cracked T-piece</p> <p>Foreign material, plastic particles, tubing obstruction</p> <p>Eye injury when nebulizer exploded (2 reports)</p> <p>Component dislodged, obstructed airway</p> <p>Potential airway obstruction caused by detached component (2 reports)</p> <p>Cracked nebulizer (4 reports)</p> <p>T-piece occlusion</p> <p>Inhaled plastic screen material, user error, forced nebulizer mouthpiece cap into spacer, rupturing screen</p>
Infection	<p><i>Pseudomonas pickettii</i> (<i>Ralstonia pickettii</i>) infection caused by contaminated solutions (4 reports)</p> <p>Mould inside tubing</p>
Injury	<p>Tachycardia, unconsciousness, lack of breathing</p> <p>Loss of consciousness</p>
Low humidity	<p>Nebulizer humidifier failed on oxygen concentrator, plugged ET, mucus became firm, desaturation, hypercarbia</p> <p>Mucus plug to trach, no misting</p>
Low output	<p>No aerosol, Venturi malfunction, no therapy</p> <p>Failure to nebulize DTPA</p> <p>Low output, low flow rate, no therapy, asthma attack</p> <p>Hypoxia, desaturation caused by malfunction and absence of visual and audio alarms when gas stopped flowing</p> <p>Airflow restriction, nebulizer malfunction</p> <p>Missing components, missing Venturi, no therapy</p> <p>Low output, albuterol</p> <p>Fails to nebulize when nylon screw is removed</p> <p>Injury due to defective nebulizer cap</p> <p>Death due to compressor motor failure</p> <p>Asthma due to lack of nebulization</p>
Medication error	<p>Low-potency albuterol</p>

ISO 27427:2013(E)

CAUSE	REPORT
Medication error	Foaming nebulizer albuterol solution in ventilator circuit, desaturation, requiring paralysis to tolerate ventilator settings, tachycardia Medication error, sterile water for inhalation was administered intravenously (IV), body rash
Misconnection	Reverse aerosolization Connected directly to tracheal tube (3 reports) Ventilator circuit misconnection, ventilator bypassed
Mismarking	Desaturation, hypercarbia, high-breathing rate caused by inadequate O ₂ caused by inaccurate % O ₂ markings on the air entrainment valve Mismarking, poor labelling
Missing components	Worsening symptoms, reactive airway disease, desaturation, missing exhalation valve in aerochamber Missing components, loss of aerosol
Overfill	Water overflow from bag into a nasal cannula, aspiration of water, required suctioning, desaturation requiring high O ₂ % for days
Oxygen coupler cracked	Cracked FiO ₂ collar, low O ₂ % Oxygen coupler malfunction, gas leak, bottle fell to floor, desaturation Cracked oxygen connector, desaturation Oxygen connector cracked, desaturation Oxygen gas coupler defective
Oxygen restriction	Desaturation not functioning, "backing up" oxygen Oxygen restriction, bottle not opening properly Restricted output, restricted oxygen flow Oxygen connector malfunction, improper oxygen flow Obstructed gas flow Diaphoresis, tachypnoea, desaturation, poor oxygen flow Death, cardiopulmonary failure, nebulizer stem broken
Oxygen restriction – leaks	Leaking oxygen tubing (2 reports)
Use error	Auto power converter did not function, no aerosol , no therapy (unit did not have converter, user error)

E.3 Potential risk controls

Potential risk controls are as follows:

- a) design
- b) instructions for use

- c) labelling
- d) pre-use checks
- e) education/training
- f) compatibility testing
- g) disclosure
- h) risk assessment

Annex F (informative)

Classification of general purpose nebulizers

F.1 Classification by aerosol matter phase or state

- dry power **aerosols** (excluded from this International Standard)
- liquid **aerosols**

F.2 Classification by duration

F.2.1 Continuous nebulizers

- **aerosol** produced continuously over multiple inhalations/exhalations

F.2.2 Breathing cycles

- **aerosol** produced continuously over long periods

F.2.3 Breath-actuated nebulizers

- triggered mechanically (by the patient on inhalation)
- triggered by negative/positive inhalation/exhalation pressure
- triggered by flow
- triggered by volume
- triggered by inhalation/exhalation gas temperature change
- triggered throughout inhalation
- triggered during the first fraction of inhaled tidal volume
- triggered at the end of exhalation

F.3 Classification by propellant

F.3.1 Gas-driven nebulizers

- atomizers, liquid and gas forced through the orifice under high pressure
- Babington style (water flowing over a sphere with a gas jet, with or without impactor)
- Venturi style (aspirating orifices)
 - perpendicular orifices, one for gas, one for drugs
 - concentric orifices with concentric cylinders
 - with or without impactor

- with or without oxygen dilution by air entrainment
- with or without condensing devices to control output and particle size

F.3.2 Spinning disc nebulizers

- spinning disc (or plate) propels pumped drug/liquid into impactor combs

F.3.3 Ultrasonic nebulizers

- piezoelectric transducers in a couplant liquid
- piezoelectric transducers acting directly on the drug

F.3.4 Vibrating nebulizers

- vibrating active mesh
- vibrating passive mesh
- vibrating capillary

Annex G (informative)

Environmental aspects

G.1 General

The environmental impact generated by **nebulizing systems** and their components is mainly isolated to the following occurrences:

- impact at local environment during normal use;
- disposal of liquid for nebulization and gases with **aerosols**;
- use, cleaning, and disposal of consumables during testing and normal use;
- scrapping at the end of the life cycle.

To highlight the importance of reducing the environmental burden, this International Standard addresses the requirements or recommendations intended to decrease the environmental impact caused by those aspects during different stages of the life cycle of **nebulizing systems** and their components.

See [Table G.1](#) for a map of the life cycle of **nebulizing systems** and their components related to the aspects of the environment.

NOTE This annex and Table G.1 are based on CEN Guide 4 and EN 13544-1:2007+A1:2009, Annex EE, with the subclauses remapped to the subclauses in this International Standard.

Table G.1 — Environmental aspects addressed by the clauses of this International Standard

Environmental aspects Inputs/outputs		Product life cycle			
		Production and preproduction Stage A	Distribution (including packaging) Stage B	Use Stage C	End of life Stage D
		Addressed in the following clauses			
1	Energy consumption	-	-	4.3	-
2	Emission to air	-	-	4.3 5.4.1 g), h) Clause 7 Clause 8	5.4.9
3	Emission to water	-	-	4.3 Clause 7	5.4.9
4	Waste	-	4.3 4.5	4.3 5.2.1 5.4 Clause 7	4.3 4.6 4.7.2 4.7.3 5.2.1 5.2.2 5.4 5.4.9
5	Noise	-	-	4.3 5.4.2 m)	-

Table G.1 (continued)

Environmental aspects Inputs/outputs		Product life cycle			
		Production and preproduction Stage A	Distribution (including packaging) Stage B	Use Stage C	End of life Stage D
		Addressed in the following clauses			
6	Migration of hazardous substances	-	-	5.2.1 5.3 k), l) 5.4 5.4.4 Clause 7 Clause 8 8.2	5.4 5.4.9
7	Impacts to soil	-	-		5.4 5.4.9
8	Risks to the environment from accidents or misuse	-	-	4.3 5.4 6.2 Clause 7	-

Annex AA
(informative)

Conformance to essential principles

This International Standard has been prepared to support the essential principles of safety and performance of **nebulizing systems** as **medical devices** according to ISO/TR 16142:2006. This International Standard is intended to be acceptable for conformity assessment purposes.

Compliance with this International Standard provides one means of demonstrating conformance with the specific essential principles of ISO/TR 16142:2006. Other means are possible. Table AA.1 maps the clauses and subclauses of this International Standard with the essential principles of ISO/TR 16142:2006.

Table — AA.1 — Correspondence between this International Standard and the essential principles

Essential principle of ISO/TR 16142:2006	ISO/TR 16142:2006 references	Corresponding clause(s)/subclause(s) of this International Standard
A.1	ISO 14971 ISO 13485 ISO/TR 14969 ISO 14155 (all parts) IEC 60601 (all parts)	4.1 and 4.1.1 This International Standard references, in part, the requirements in ISO 14971 in 4.1.1 and usability requirements in IEC 60601-1-6 and IEC 62366.
A.2	ISO 14971 ISO 13485 ISO/TR 14969	4.1 , 4.1.1 , 4.3 , 4.4 , 4.5 , 4.6 , 4.7 , and Annex E
A.3	ISO 14971 ISO 13485 ISO/TR 14969	5.4.1 d)
A.4	ISO 14971 ISO 13485 ISO/TR 14969 ISO 14155 (all parts)	5.4.1 d) and h) and 5.4.2 5.4.7
A.5	ISO 14971 ISO 13485 ISO/TR 14969	5.3 c), g), and h)
A.6	ISO 14971 ISO 13485 ISO/TR 14969	4.1 Annex E
A.7	ISO 14971 ISO 13485 ISO/TR 14969 ISO 10993 (all parts)	4.1.1 4.3 5.4.4 6.1 Clause 8
A.7.1	ISO/TR 14969 ISO 10993 (all parts)	4.1.1 and 4.3 Annex E , 5.4 , 6.1 , and Clause 8
A.7.2	ISO/TR 14969 ISO 10993 (all parts) ISO 11607 (all parts)	7.2 Clause 8

Table (continued)

Essential principle of ISO/TR 16142:2006	ISO/TR 16142:2006 references	Corresponding clause(s)/subclause(s) of this International Standard
A.7.3	ISO 14971 ISO 10993 (all parts) ISO 11607 (all parts)	4.1.1 5.4.4 6.1.1 6.1.2 Clause 8
A.7.4	See also Pharmacopoeia and publications of authorities responsible for medicinal products/drugs	Not applicable. As supplied, nebulizing systems are not generally provided with an integral part that can be considered a medicinal product. Medicinal products are added to the nebulizing system by the user just prior to use.
A.7.5	ISO 14971 ISO 10993 (all parts) ISO 11607 (all parts) IEC 60601 (all parts)	4.3 4.4 5.3 k) 5.4.4 c) Clause 8
A.7.6	ISO 14971 ISO 10993 (all parts)	4.2 4.3, Annex E
A.8 A.8.1	ISO 14971 ISO 13485 ISO/TR 14969 ISO 11135 (all parts) ISO 11137 (all parts) ISO 11607 (all parts) ISO 11737 (all parts) ISO 13408 (all parts) ISO 14160 ISO 14937 ISO 17665 (all parts)	4.3 4.4 5.4.5 7.2 7.3
A.8.1.1	ISO 22442 (all parts) See also A.8	Not applicable.
A.8.1.2	See also A.8	Not applicable.
A.8.2	See also A.8	7.1 7.2
A.8.3	See also A.8	7.1
A.8.4	ISO 14644 (all parts) See also A.8	7.1
A.8.5	See also A.8	5.4.5 7.3
A.8.6	See note on labelling in A.13.1	5.3 d) 5.3 g)
A.9.1	IEC 60601 (all parts) ISO 594 (all parts) ISO/IEEE 11073 (all parts)	6.2 5.3 i) 5.4.1 f) 5.4.8
A.9.2	ISO 14971 IEC 60601 (all parts) ISO/IEEE 11073 (all parts)	4.3 4.4 4.5 4.6 5.4.1 5.4.2 5.4.3 5.4.8

Table (continued)

Essential principle of ISO/TR 16142:2006	ISO/TR 16142:2006 references	Corresponding clause(s)/subclause(s) of this International Standard
A.9.3	ISO 14971 IEC 60601 (all parts)	4.1.1 4.3 Annex E.2.1 a) 5.4.3 d) 6.1.1
A.10	ISO 14971 ISO 13485 ISO/TR 14969 IEC 60601 (all parts)	Not applicable. No measuring functions.
A.10.1	ISO 14971 ISO/IEEE 11073 (all parts)	Not applicable. No measuring functions.
A.10.2	ISO 14971	Not applicable. No measuring functions.
A.10.3	See also note in A.13.1	Not applicable. No measuring functions.
A.11	ISO 14971 ISO 13485 ISO/TR 14969 IEC 60601 (all parts)	5.4.8 4.1.1 Annex E.1 d) 5)
A.11.1	See also A.11	5.4.8 4.1.1 Annex E.1 d) 5)
A.11.2	See also A.11	Not applicable. No intended radiation.
A.11.2.1	See also A.11	Not applicable. No intended radiation.
A.11.2.2	See also A.11	Not applicable. No intended radiation.
A.11.3	See also A.11	Not applicable. No intended radiation.
A.11.4	See also A.11	Not applicable. No intended radiation.
A.11.5	See also A.11	Not applicable. No intended radiation.
A.11.5.1	See also A.11	Not applicable. No intended radiation.
A.11.5.2	See also A.11	Not applicable. No intended radiation.
A.11.5.3	See also A.11	Not applicable. No intended radiation.
A.12	ISO 14971 ISO 13485 ISO/TR 14969 ISO 14155 (all parts) IEC 60601 (all parts) IEC 61010 (all parts) ^[23]	4.3
A.12.1	IEC 60601-1-4 ^[21] See also A.12	4.3
A.12.2	See A.12	4.3
A.12.3	See A.12	4.3
A.12.4	See A.12	Not applicable. No patient monitoring.
A.12.5	See A.12	5.4.8
A.12.6	See A.12	4.3
A.12.7	See A.12	4.4
A.12.7.1	See A.12	4.4
A.12.7.2	See A.12	4.4
A.12.7.3	See A.12	5.4.2 m)

Table (continued)

Essential principle of ISO/TR 16142:2006	ISO/TR 16142:2006 references	Corresponding clause(s)/subclause(s) of this International Standard
A.12.7.4	See A.12	6.2
A.12.7.5	See A.12	5.4.1 g)
A.12.8	See A.12	4.3 4.6 5.2.2
A.12.8.1	See A.12	4.3 4.6 5.2.2
A.12.8.2	See A.12	4.3 4.6 5.2.2
A.12.8.3	See A.12	5.2.2
A.13	ISO 13485 ISO/TR 14969	Clause 5
A.13.1	ISO 7000 IEC 60417 IEC/TR 60878 ISO 15223-1	Clause 5 5.1 5.2 5.3 5.4
A.14	ISO 14971 ISO 13485 ISO/TR 14969 ISO 14155 (all parts)	4.1.1 4.1.2 Annex E
A.14.1	ISO 14155 (all parts)	4.1.1 4.1.2 Annex E

Bibliography

- [1] ISO 3744, *Acoustics — Determination of sound power levels and sound energy levels of noise sources using sound pressure — Engineering methods for an essentially free field over a reflecting plane*
- [2] ISO 5361, *Anaesthetic and respiratory equipment — Tracheal tubes and connectors*
- [3] ISO 8185, *Respiratory tract humidifiers for medical use — Particular requirements for respiratory humidification systems*
- [4] ISO 9276-1, *Representation of results of particle size analysis — Part 1: Graphical representation*
- [5] ISO 9276-2, *Representation of results of particle size analysis — Part 2: Calculation of average particle sizes/diameters and moments from particle size distributions*
- [6] ISO/IEEE 11073 (all parts), *Health informatics — Personal health device communication*
- [7] ISO 11607 (all parts), *Packaging for terminally sterilized medical devices*
- [8] ISO 11737 (all parts), *Sterilization of medical devices — Microbiological methods*
- [9] ISO 13408 (all parts), *Aseptic processing of health care products*
- [10] ISO 13485, *Medical devices — Quality management systems — Requirements for regulatory purposes*
- [11] ISO 14155 (all parts), *Clinical investigation of medical devices for human subjects*
- [12] ISO 14160, *Sterilization of health care products — Liquid chemical sterilizing agents for single-use medical devices utilizing animal tissues and their derivatives — Requirements for characterization, development, validation and routine control of a sterilization process for medical devices*
- [13] ISO 14644 (all parts), *Cleanrooms and associated controlled environments*
- [14] ISO 14937, *Sterilization of health care products — General requirements for characterization of a sterilizing agent and the development, validation and routine control of a sterilization process for medical devices*
- [15] ISO/TR 14969, *Medical devices — Quality management systems — Guidance on the application of ISO 13485: 2003*
- [16] ISO 15002, *Flow-metering devices for connection to terminal units of medical gas pipeline systems*
- [17] ISO 17664, *Sterilization of medical devices — Information to be provided by the device manufacturer for the processing of reusable medical devices*
- [18] ISO 20072:2009, *Aerosol drug delivery device design verification — Requirements and test methods*
- [19] ISO 22442 (all parts), *Medical devices utilizing animal tissues and their derivatives*
- [20] IEC 60417, *Graphical symbols for use on equipment*
- [21] IEC 60601-1-4, *Medical electrical equipment — Part 1-4: General requirements for safety — Collateral Standard: Programmable electrical medical systems*
- [22] IEC/TR 60878, *Graphical symbols for electrical equipment in medical practice*
- [23] IEC 61010 (all parts), *Safety requirements for electrical equipment for measurement, control, and laboratory use*
- [24] IEC 61672-1, *Electroacoustics — Sound level meters — Part 1: Specifications*

- [25] ISO 80369-2, *Small-bore connectors for liquids and gases in healthcare applications — Part 2: Connectors for breathing systems and driving gases applications (under development)*
- [26] ISO 80601-2-12, *Medical electrical equipment — Part 2-12: Particular requirements for basic safety and essential performance of critical care ventilators*
- [27] ISO 80601-2-13, *Medical electrical equipment — Part 2-13: Particular requirements for basic safety and essential performance of an anaesthetic workstation*
- [28] EN 1041:2008, *Information supplied by the manufacturer of medical devices*
- [29] EN 13544-1, *Respiratory therapy equipment — Part 1: Nebulizing systems and their components*
- [30] BARRY P.W., & O'CALLAGHAN C. An in vitro analysis of the output of salbutamol from different nebulizers. *Eur. Respir. J.* 1999 May, **13** pp. 1164–1169
- [31] DENNIS J.H., PIERON C.A., PAGELS J., SMURTHWAITE M., NERBRINK O. Development and application of a low flow cascade impactor to size nebulized aerosols. *J. Aerosol Med.* 1999, **12** p. 134
- [32] DENNIS J.H., STENTON S.C., BEACH J.R., AVERY A.J., WALTERS E.H., HENDRICK D.J. Jet and ultrasonic nebuliser output: use of a new method for direct measurement of aerosol output. *Thorax.* 1990 Oct, **45** pp. 728–732
- [33] DOLOVICH M. *Can. Respir. J.* 2004, **11** pp. 489–496
- [34] European Pharmacopoeia, Inhalanda (5th edition)
- [35] HEYDER J., GEBHART J., RODULF T.G., SCHILLER C.F., STAHLHOFEN W. Deposition of particles in the human respiratory tract in the size range 0.005 – 15 µm. *J. Aerosol Sci.* 1986, **17** pp. 811–825
- [36] NFPA 53M – Manual on fire hazards in oxygen enriched atmosphere, National Fire Protection Association, 1 Batterymarch Park, P.O. Box 9101, Quincy, MA 02269-9101, USA
- [37] NIVEN R.W. et al. Some factors associated with the ultrasonic nebulization of proteins. *Pharm. Res.* 1995 Jan, **12** pp. 53–59
- [38] RAU J.L., ARI A., RESTREPO R.D. Performance comparison of nebulizer designs: constant-output, breath-enhanced, and dosimetric. *Respir. Care.* 2004 Feb, **49** pp. 174–179
- [39] STAHLHOFEN W., RUDOLPH G., JAMES A.C. Intercomparison of experimental regional deposition data. *J. Aerosol Med.* 1989, **2** pp. 285–308
- [40] U.S. Food and Drug Administration, Reviewer Guidance for Nebulizers, Metered Dose Inhalers, Spacers and Actuators, October 1, 1993
- [41] ISO 10993-2, *Biological evaluation of medical devices — Part 2: Animal welfare requirements*
- [42] ISO 10993-3, *Biological evaluation of medical devices — Part 3: Tests for genotoxicity, carcinogenicity and reproductive toxicity*
- [43] ISO 10993-4, *Biological evaluation of medical devices — Part 4: Selection of tests for interactions with blood*
- [44] ISO 10993-5, *Biological evaluation of medical devices — Part 5: Tests for in vitro cytotoxicity*
- [45] ISO 10993-6, *Biological evaluation of medical devices — Part 6: Tests for local effects after implantation*
- [46] ISO 10993-7, *Biological evaluation of medical devices — Part 7: Ethylene oxide sterilization residuals*
- [48] ISO 10993-9, *Biological evaluation of medical devices — Part 9: Framework for identification and quantification of potential degradation products*

ISO 27427:2013(E)

- [49] ISO 10993-10, *Biological evaluation of medical devices — Part 10: Tests for irritation and skin sensitization*
- [50] ISO 10993-11, *Biological evaluation of medical devices — Part 11: Tests for systemic toxicity*
- [51] ISO 10993-12, *Biological evaluation of medical devices — Part 12: Sample preparation and reference materials*
- [52] ISO 10993-13, *Biological evaluation of medical devices — Part 13: Identification and quantification of degradation products from polymeric medical devices*
- [53] ISO 10993-14, *Biological evaluation of medical devices — Part 14: Identification and quantification of degradation products from ceramics*
- [54] ISO 10993-15, *Biological evaluation of medical devices — Part 15: Identification and quantification of degradation products from metals and alloys*
- [55] ISO 10993-16, *Biological evaluation of medical devices — Part 16: Toxicokinetic study design for degradation products and leachables*
- [56] ISO 10993-17, *Biological evaluation of medical devices — Part 17: Establishment of allowable limits for leachable substances*
- [57] ISO 10993-18, *Biological evaluation of medical devices — Part 18: Chemical characterization of materials*
- [58] ISO 10993-19, *Biological evaluation of medical devices — Part 19: Physico-chemical, morphological and topographical characterization of materials*
- [59] ISO 10993-20, *Biological evaluation of medical devices — Part 20: Principles and methods for immunotoxicology testing of medical devices*

ISO 27427:2013(E)

www.iso.org/iso/27427

ICS 11.040.10

Price based on 48 pages