

---

---

**Ophthalmic implants — Intraocular  
lenses —**

**Part 2:  
Optical properties and test methods**

*Implants ophtalmiques — Lentilles intraoculaires —  
Partie 2: Propriétés optiques et méthodes d'essai*





**COPYRIGHT PROTECTED DOCUMENT**

© ISO 2014

All rights reserved. Unless otherwise specified, no part of this publication may be reproduced or utilized otherwise in any form or by any means, electronic or mechanical, including photocopying, or posting on the internet or an intranet, without prior written permission. Permission can be requested from either ISO at the address below or ISO's member body in the country of the requester.

ISO copyright office  
Case postale 56 • CH-1211 Geneva 20  
Tel. + 41 22 749 01 11  
Fax + 41 22 749 09 47  
E-mail [copyright@iso.org](mailto:copyright@iso.org)  
Web [www.iso.org](http://www.iso.org)

Published in Switzerland

Licensed to [rajan@stephensinst.com](mailto:rajan@stephensinst.com)  
ISO Store order #: OP-58694/Downloaded: 2015-03-19  
Single user licence only, copying and networking prohibited.

# Contents

	Page
<b>Foreword</b> .....	<b>iv</b>
<b>Introduction</b> .....	<b>v</b>
<b>1 Scope</b> .....	<b>1</b>
<b>2 Normative references</b> .....	<b>1</b>
<b>3 Terms and definitions</b> .....	<b>1</b>
<b>4 Requirements</b> .....	<b>1</b>
4.1 General .....	1
4.2 Dioptric power .....	2
4.3 Determination of imaging quality .....	3
4.4 Spectral transmittance .....	5
<b>Annex A (normative) Measurement of dioptric power</b> .....	<b>6</b>
<b>Annex B (normative) Measurement of resolution efficiency</b> .....	<b>14</b>
<b>Annex C (normative) Measurement of MTF</b> .....	<b>17</b>
<b>Bibliography</b> .....	<b>22</b>

## Foreword

ISO (the International Organization for Standardization) is a worldwide federation of national standards bodies (ISO member bodies). The work of preparing International Standards is normally carried out through ISO technical committees. Each member body interested in a subject for which a technical committee has been established has the right to be represented on that committee. International organizations, governmental and non-governmental, in liaison with ISO, also take part in the work. ISO collaborates closely with the International Electrotechnical Commission (IEC) on all matters of electrotechnical standardization.

International Standards are drafted in accordance with the rules given in the ISO/IEC Directives, Part 2.

The main task of technical committees is to prepare International Standards. Draft International Standards adopted by the technical committees are circulated to the member bodies for voting. Publication as an International Standard requires approval by at least 75 % of the member bodies casting a vote.

Attention is drawn to the possibility that some of the elements of this document may be the subject of patent rights. ISO shall not be held responsible for identifying any or all such patent rights.

ISO 11979-2 was prepared by Technical Committee ISO/TC 172, *Optics and photonics*, Subcommittee SC 7, *Ophthalmic optics and instruments*.

This second edition cancels and replaces the first edition (ISO 11979-2:1999), which has been technically revised. It also incorporates the Technical Corrigendum ISO 11979-2:1999/Cor.1:2003.

ISO 11979 consists of the following parts, under the general title *Ophthalmic implants — Intraocular lenses*:

- *Part 1: Vocabulary*
- *Part 2: Optical properties and test methods*
- *Part 3: Mechanical properties and test methods*
- *Part 4: Labelling and information*
- *Part 5: Biocompatibility*
- *Part 6: Shelf-life and transport stability testing*
- *Part 7: Clinical investigations*
- *Part 8: Fundamental requirements*
- *Part 9: Multifocal intraocular lenses*
- *Part 10: Phakic intraocular lenses*

## Introduction

This part of ISO 11979 initially addressed monofocal IOLs and now has been revised to include the requirements and test methods for spherical monofocal, aspheric monofocal, toric, multifocal, and accommodative IOLs. This part of ISO 11979 contains several test methods for which associated requirements are given and one test method for which no requirement is formulated. The former are directly connected to the optical functions of intraocular lenses. The latter, the test for spectral transmittance, has been provided for information about UV transmission and in specific situations, e.g. when using laser light sources for diagnosis and treatment.

For the original spherical monofocal IOLs, extensive interlaboratory testing was carried out before setting the limits specified. During this testing some basic problems were encountered as described in Reference [1]. The accuracy in the determination of dioptric power has an error that is not negligible in relation to the half dioptre steps in which intraocular lenses are commonly labelled. The dioptric power tolerances take this fact into account. Hence the limits set may lead to some overlap into the next labelled power, especially for high dioptre lenses. Reference [1] gives further discussion on this subject.

The majority of lenses hitherto implanted were qualified using the method described in [Annex B](#) or [Annex C](#) (model eye 1). The method in [Annex B](#) is limited in its applicability, however. The limits for the more general method in [Annex C](#) have been set in terms of MTF in a model eye, following two approaches. The first is by correlation to the method and limit in [Annex B](#). Further discussion can be found in Reference [2]. The second is set as a percentage of what is calculated as theoretical maximum for the design, with the rationale that a minimum level of manufacturing accuracy be guaranteed. For common PMMA lenses, these two limits correspond well with each other. For lenses made of materials with lower refractive index, or with certain shape factors, or for extreme power lenses in general, the latter limit is lower than the former. However, such lenses are already in use, indicating clinical acceptance. The question of which is the absolute lowest limit that is compatible with good vision arises. No definite answer can be found, but following clinical data presented to the working group, an absolute lower limit has been set for the calculation method.



# Ophthalmic implants — Intraocular lenses —

## Part 2: Optical properties and test methods

### 1 Scope

This part of ISO 11979 specifies requirements and test methods for certain optical properties of intraocular lenses (IOLs) with any of spherical, aspheric, monofocal, toric, multifocal, and/or accommodative optics. The generic descriptor 'IOL' used throughout this document also includes phakic intraocular lenses (PIOL).

### 2 Normative references

The following referenced documents are indispensable for the application of this document. For dated references, only the edition cited applies. For undated references, the latest edition of the referenced document (including any amendments) applies.

ISO 6328:2000, *Photography — Photographic materials — Determination of ISO resolving power*

ISO 9334, *Optics and photonics — Optical transfer function — Definitions and mathematical relationships*

ISO 9335, *Optics and photonics — Optical transfer function — Principles and procedures of measurement*

ISO 11979-1, *Ophthalmic implants — Intraocular lenses — Part 1: Vocabulary*

ISO 11979-3, *Ophthalmic implants — Intraocular lenses — Part 3: Mechanical properties and test methods*

ISO 11979-4, *Ophthalmic implants — Intraocular lenses — Part 4: Labelling and information*

### 3 Terms and definitions

For the purposes of this document, the terms and definitions given in ISO 11979-1 and ISO 9334 apply.

### 4 Requirements

#### 4.1 General

The manufacturer shall demonstrate that the entire range of available powers meets the specifications herein. All optical properties apply at *in situ* conditions, either by being measured at simulated *in situ* conditions, or being measured at other conditions and then corrected to *in situ* conditions.

For IOLs where the optic is intended to be deformed during implantation, it shall be demonstrated that dioptric power and imaging quality are retained at *in situ* conditions or equivalent following surgical manipulation and recovery. See ISO 11979-3 for more detail.

The test methods described in this standard are reference methods. Alternative methods that produce equivalent results to those obtained with the reference methods can be used if the manufacturer can demonstrate that the IOLs meet the minimum dioptric power and imaging quality requirements.

## 4.2 Dioptric power

### 4.2.1 General

The dioptric power of spherical or aspheric lenses as stated by the manufacturer in the IOL labelling shall be within the tolerance limits specified in [Table 1](#). For rotationally symmetric lenses, these tolerances apply in all meridians.

**Table 1 — Tolerance limits on spherical dioptric power, *S***

Nominal spherical dioptric power range <sup>a</sup> D	Tolerance limits on spherical dioptric power D
$0 \leq S \leq 15$	$\pm 0,3$
$15 < S \leq 25$	$\pm 0,4$
$25 < S \leq 30$	$\pm 0,5$
$30 < S$	$\pm 1,0$

<sup>a</sup> The ranges apply to positive as well as negative dioptric powers.

### 4.2.2 Dioptric power for toric IOL (TIOL)

When determined by any of the methods in [Annex A](#), the dioptric power in the meridians of highest and lowest dioptric power and the spherical equivalent (SE) power shall be within the tolerance limits for dioptric power specified in [Table 1](#). Additionally, the cylindrical power calculated as the absolute difference between the powers of the meridian of highest dioptric power and the meridian of lowest dioptric power shall be within the cylindrical power tolerance limits specified in [Table 2](#).

**Table 2 — Tolerance limits on cylindrical dioptric power, *C***

Nominal cylindrical dioptric power range D	Tolerance limits on cylindrical dioptric power D	
	SE < 25 D	SE ≥ 25 D
$0 < C \leq 2,5$	$\pm 0,3$	$\pm 0,4$
$2,5 < C \leq 4,5$	$\pm 0,4$	$\pm 0,4$
$4,5 < C$	$\pm 0,5$	$\pm 0,5$

The TIOL shall have a physical axis indicator such as a mark, engraving, or label that aligns with the meridian of lowest dioptric power, and is visible to the surgeon during implantation. The angle difference between the physical axis indicator and the meridian with the lowest dioptric power shall be less than or equal to 5,0°.

### 4.2.3 Dioptric power for multifocal IOL (MIOL)

Methods [A.2](#) to [A.4](#) can be applied to MIOL for determining the far power and any distinct near powers. When using [A.2](#), dioptric power must be justified as a calculation based only on spherical surfaces. The dioptric power of the far power shall be within the tolerance limits specified in [Table 1](#) and the dioptric power of the addition power(s) shall be within the tolerances in [Table 3](#).

Table 3 — Tolerance limits on addition dioptric power, *A*

Nominal addition dioptric power range D	Tolerance limits on addition dioptric power	Tolerance limits on addition dioptric power
	D far power < 25 D	D far power ≥ 25 D
0 < A ≤ 2,5	±0,3	±0,4
2,5 < A ≤ 4,5	±0,4	±0,4
4,5 < A	±0,5	±0,5

#### 4.2.4 Dioptric power for accommodating IOL (AIOL)

The power associated with the far power configuration of an AIOL shall be determined by one of the methods in [Annex A](#). When determined by one of these methods, the dioptric power tolerances specified in [Table 1](#) shall apply to the power associated with the far power configuration of the AIOL. The dioptric change of the lens or system in the eye resulting from the accommodative action shall be determined in a theoretical or laboratory eye model.

### 4.3 Determination of imaging quality

#### 4.3.1 General

Imaging quality is dependent upon compatibility between the optical design and conditions that are used to evaluate optical performance. Imaging quality can be specified either as resolution efficiency or as the modulation transfer function (MTF) value at a specified spatial frequency. Resolution efficiency is determined according to the method described in [Annex B](#). MTF is measured according to the method in [Annex C](#).

MTF determined with the method described in [Annex C](#) is dependent on the compatibility between the optical design and model eye that is used to evaluate optical performance. For the method described in [Annex C](#), example model eye specifications are given. Alternatively, the manufacturer can specify an equivalent method or model eye with optical properties for the intended use and design. In this case the model eye and the method shall be fully described and a justification for the use be provided. The imaging quality specifications apply to all available powers, unless stated otherwise.

NOTE 1 Optical resolution is expressed in spatial frequency. In [Annex B](#), by tradition, resolution is in line-pairs per millimetre (lp/mm) and in [Annex C](#) in cycles per millimetre (c/mm or mm<sup>-1</sup>). In the ophthalmic literature, cycles per degree is often used. For the eye, assuming a nodal point distance of 17 mm in image space, the conversion between the two is:

$$c/\text{degree} = 0,297 * c/\text{mm}$$

NOTE 2 The test apertures given in the subclauses of [4.3](#) and in [Annexes A, B, and C](#) represent the exposed central area of the IOL under test, which can differ from the aperture stop of the test system.

#### 4.3.2 Monofocal lenses

##### 4.3.2.1 General

Imaging quality for monofocal IOLs shall fulfil one of the requirements in [4.3.2.2](#), [4.3.2.3](#) or [4.3.2.4](#).

##### 4.3.2.2 Resolution efficiency

If determined in accordance with [Annex B](#), the resolution efficiency of the IOL shall be no less than 60 % of the diffraction limited cut-off spatial frequency for a 3 mm aperture. In addition, the image shall be

virtually free of detectable aberrations except due to spherical aberration normally expected for the lens design.

#### 4.3.2.3 MTF using model eye 1

If determined in accordance with [Annex C](#) using model eye 1 ([C.3.1](#)), the MTF value of the model eye with IOL configuration shall at  $100 \text{ mm}^{-1}$  meet either of the two requirements given below:

- a) be greater than or equal to 0,43;
- b) be greater than or equal to 70 % of the maximum theoretically attainable modulation for the specific IOL design, but in any case be greater than or equal to 0,28.

NOTE The acceptance levels given in [4.3.2.2](#) and [4.3.2.3 a\)](#) correspond well with each other for PMMA lenses in the range of 10 D to 30 D<sup>[2]</sup>.

#### 4.3.2.4 MTF using model eye 2

If determined in accordance with [Annex C](#) using model eye 2 ([C.3.2](#)), the MTF value of the configuration of model eye with IOL shall at  $100 \text{ mm}^{-1}$  be greater than or equal to 70 % of the maximum theoretical attainable MTF for a 3 mm aperture, but in any case greater than or equal to 0,28.

### 4.3.3 Toric IOL (TIOL)

#### 4.3.3.1 General

Imaging quality for toric IOLs shall fulfil one of the requirements in [4.3.3.2](#) or [4.3.3.3](#).

#### 4.3.3.2 Resolution efficiency

When the null lens method described in [Annex B](#) is used, the general resolution efficiency requirements in [4.3.2.2](#) shall apply to the combined system of toric IOL and null lens.

#### 4.3.3.3 MTF

The MTF requirements described in [4.3.2.3](#) or [4.3.2.4](#) shall apply to the meridians of highest and lowest dioptric power.

### 4.3.4 Multifocal IOL (MIOL)

#### 4.3.4.1 MTF

The imaging quality specifications apply in all meridians, unless the MIOL also comprises a cylinder component, in which case the considerations of [4.3.6](#) apply. The imaging quality of a MIOL shall be evaluated by modulation transfer function (MTF) testing in one of the model eyes described in [Annex C](#) with the following additions:

The method in [Annex C](#) is modified such that best focus for the dioptric power under evaluation is obtained by maximizing the MTF at  $50 \text{ mm}^{-1}$  with a  $3,0 \text{ mm} \pm 0,1 \text{ mm}$  aperture. Using that focus, record the MTF values at the following conditions:

- a) small aperture (2 mm to 3 mm),  $25 \text{ mm}^{-1}$  and  $50 \text{ mm}^{-1}$ , for the far dioptric power;
- b) large aperture (4 mm to 5 mm),  $25 \text{ mm}^{-1}$  and  $50 \text{ mm}^{-1}$ , for the far dioptric power;
- c) small aperture (2 mm to 3 mm),  $25 \text{ mm}^{-1}$  and  $50 \text{ mm}^{-1}$ , for the near dioptric power(s) or power range.

In order to best control the MTF performance of the MIOL, the small and large apertures used for testing shall be chosen and defined for the lens model over the range of apertures provided above with a tolerance of  $\pm 0,1$  mm. The manufacturer shall have the option of setting the minimum MTF specification based on the area under the curve between the two spatial frequencies or on the MTF value for each individual spatial frequency. The MTF shall be greater than or equal to 70 % of the maximum theoretically attainable modulation for the specific IOL design. Alternatively, the minimum MTF specification shall be set such that it results in an acceptable visual outcome, verifiable, or to be verified, by clinical data.

#### 4.3.5 Accommodating IOL (AIOL)

The requirements given in [4.3.2](#) shall apply at the far power configuration and configurations associated with the designed range of accommodation. Measurements shall be obtained in 0,5 D or smaller increments over this range if applicable.

#### 4.3.6 Combination of optical principles

For toric multifocal and toric accommodating lenses, the general imaging requirements for all principles in [4.3.3](#) apply along with the special test requirements in [4.3.4](#) and [4.3.5](#), respectively.

For multifocal accommodating lenses the imaging requirements of [4.3.4](#) and [4.3.5](#) apply.

#### 4.3.7 Exceptions

If the criteria specified in [4.3.2](#) through [4.3.6](#), for reasons of theoretical limitation, cannot be applied to negative and low power lenses in conjunction with the model eye described, the manufacturer shall justify any alternate spatial frequencies and criteria applied.

### 4.4 Spectral transmittance

#### 4.4.1 Measurement of spectral transmittance

The spectral transmittance in the range 300 nm to 1 100 nm shall be recorded by a UV/Visible spectrophotometer with a 3 mm aperture in aqueous, or be corrected for specular reflection if measured in air. The measurement should be accurate to  $\pm 2$  % transmittance and the resolution should not be less than 5 nm. The test specimen shall be either an actual IOL or a flat facsimile of the IOL optic material, having a thickness equal to the centre thickness of a 20 D IOL and having undergone the same production treatment as the finished IOL including sterilization.

#### 4.4.2 Cut-off wavelength

Designate UV cut-off as UV(XXX) where XXX is the wavelength in nanometres at which the spectral transmission is below 10 % when measured according to [4.4.1](#).

NOTE Guidance for the measurement of spectral transmittance can be found in ISO 18369-3:2006[3].

## Annex A (normative)

### Measurement of dioptric power

#### A.1 General

Multiple methods of determining IOL dioptric power are given below. The specific methods and requirements for spherical and aspheric monofocal, toric, or multifocal IOL measurement are described in this annex where applicable.

For all IOLs, the value of dioptric power is defined at *in situ* conditions (see ISO 11979-1) for a light source that has a peak wavelength within  $\pm 10$  nm of 546 nm having a full width at half maximum of 20 nm or less. For the methods in [A.3](#) and [A.4](#), an aperture of  $3,0 \pm 0,1$  mm in diameter is used.

NOTE 1 For more details about optical measurement and calculations, see Reference [\[4\]](#) or similar textbooks on optics.

NOTE 2 A modified bench (e.g. additional converging lens, a microscope objective of appropriate numerical aperture, etc.) may be needed to quantify the focal length of negative and low dioptric power IOLs.

#### A.2 Determination of dioptric power by calculation from measured dimensions

##### A.2.1 Procedure

Measure the surface radii over a region of approximately 3 mm diameter using a radius meter, interferometer, or optical coherence tomograph (OCT)[\[5\]](#). Measure the lens thickness with a micrometer or equivalent device. Calculate the dioptric power, using the Equation:

$$D = D_f + D_b - (t_c / n_{IOL}) D_f D_b \quad (A.1)$$

under *in situ* conditions, where

$D$  is the dioptric power of the IOL;

$D_f$  is the dioptric power of the front surface of the IOL;

$D_b$  is the dioptric power of the back surface of the IOL;

$t_c$  is the central thickness, in metres, of the IOL;

$n_{IOL}$  is the refractive index of the IOL optic material at *in situ* conditions.

NOTE 1 Formula (A.1) is often referred to as the “thick lens equation”.

NOTE 2 In general, the value of  $n_{IOL}$  is influenced by temperature and water uptake by the IOL optic material.

Calculate  $D_f$  from the Equation:

$$D_f = (n_{IOL} - n_{med}) / r_f \quad (A.2)$$

where

$n_{med}$  is the refractive index of the surrounding medium;

$r_f$  is the radius, in metres, of the front surface of the IOL.

Calculate  $D_b$  from the Equation:

$$D_b = (n_{med} - n_{IOL}) / r_b \quad (A.3)$$

where

$r_b$  is the radius, in metres, of the back surface of the IOL.

NOTE 3 With respect to the incidence of light, a convex radius is positive and a concave radius is negative.

NOTE 4 These equations assume that there is exact alignment of front and back surfaces along the optical axis.

NOTE 5 ISO 18369-4:2006<sup>[6]</sup> describes a method that may be used to determine  $n_{IOL}$ , which should be known to the third decimal place.

NOTE 6 If the lens material is flexible, appropriate care must be taken when measuring the two lens surfaces to ensure that the two surface measurements are consistent with each other. Any flexing of the lens between the measurements of the two surfaces will affect the results.

Use  $n_{med} = 1,336$ , and the dimensions and refractive index of the IOL under *in situ* conditions to obtain the dioptric power *in situ*,  $D_{aq}$ , from Formula (A.1).

If the measured dimensions and the refractive index of the IOL were not obtained under *in situ* conditions, apply proper corrections to calculate the corresponding values at *in situ* conditions.

## A.2.2 Applicability

This method as described is applicable to rotationally symmetric spherical IOLs.

Due to the complexity of MIOL and TIOL optical designs, this method should be limited to monofocal IOLs.

## A.3 Determination of dioptric power from measured back focal length or effective focal length

### A.3.1 Principle

The method described in the subclauses of [A.3](#) assumes measurement in air, but is applicable to measurement at simulated *in situ* conditions with proper adjustments.

The back focal length (*BFL*) is the distance from the back vertex of the IOL to the focal point with parallel light incident on-axis upon the IOL. This method has historically been used to measure monofocal lenses in air.

The effective focal length (*EFL*) is the distance from the second principal plane to the focal point with parallel light incident on-axis upon the IOL. *EFL* can be measured with a nodal slide bench.<sup>[4]</sup>

Both methods can be applied to IOL, MIOL, and TIOL when appropriate corrections are made as described below.

NOTE 1 The position of the focal point is dependent on the spatial frequency used to find the focal point. It is normally not coincident with the paraxial focal point of the lens under measurement if there is spherical aberration. The focus found is often referred to as “best focus”.

NOTE 2 *BFL*, *EFL*, and the corrections are all vector quantities. The positive direction is that of the incident light and is measured along the optical axis.

### A.3.2 Apparatus

A.3.2.1 An optical bench, e.g. as illustrated in [Figure A.1](#), having the following features:

- a) a collimator achromat which is virtually free from aberrations in combination with the light source used, having a focal length preferably at least 10 times that of the IOL being measured;
- b) a spatial frequency target such as the U.S. Air Force 1951 Resolution Target<sup>[Z]</sup> (see [Figure B.1](#)), diffusely illuminated by a light source in the focal plane of the collimator;
- c) an aperture stop of 3,0 mm ± 0,1 mm placed maximally 3 mm in front of the IOL being measured;
- d) a surrounding medium of air;
- e) a microscope objective with a numerical aperture greater than that of the test system and capable of magnifying ×10 to ×20;
- f) an eye-piece magnifying about ×10.

NOTE 1 To measure a focal length longer than the testing apparatus, an additional converging lens or microscope objective of appropriate numerical aperture may be needed.

NOTE 2 It is a matter of convenience whether to use a straight bench or employ a mirror as illustrated in [Figure A.1](#).

The microscope is connected to a position measuring device so that its position along the optical axis can be determined with an precision of 0,01 mm.

### A.3.3 Procedure

A.3.3.1 Mount the IOL on the optical bench just behind the 3 mm aperture.

A.3.3.2 Focus the microscope at the back surface of the IOL and note the position of the microscope.

A.3.3.3 Focus the microscope at the image of the target and note the position of the microscope. The distance from the back vertex of the IOL to the focal point is the back focal length, *BFL*, of the IOL.

Focusing is done at 0,3 of the MTF cut-off frequency. The procedure given here assumes that measurement is done in air at normal ambient conditions of a laboratory. The calculations assume that the dimensions of the IOL are not appreciably different under *in situ* conditions. Should that not be the case, *BFL* is measured with the IOL under simulated *in situ* conditions, with appropriate changes in the calculations.

A.3.3.4 Calculate the distance from the back vertex of the IOL to the back principal plane of the IOL

$$-A_2H'' = (D_f / D) \cdot (n_{\text{med}} / n_{\text{IOL}}) \cdot t_c \tag{A.4}$$

where

$n_{\text{med}} = 1$  for measurement in air.

NOTE 1  $A_2H''$  is a vector that can be positive or negative depending on lens shape. The quantity  $-A_2H''$  is added to BFL as correction.

NOTE 2 This correction does not apply to *EFL*.

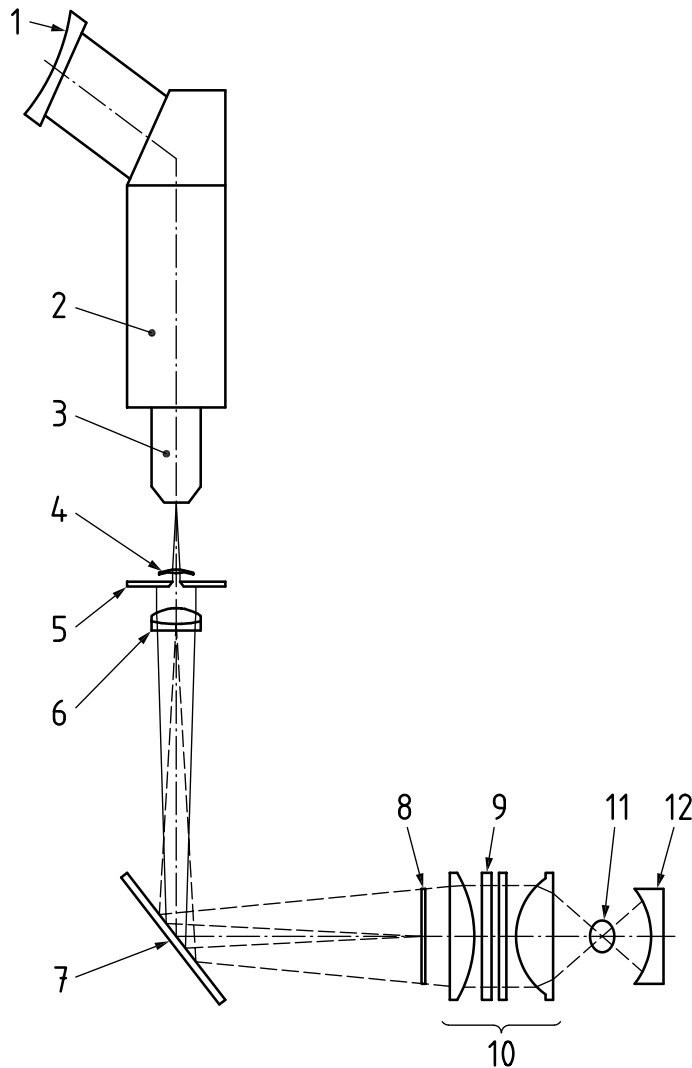

**Key**

- |                        |                            |
|------------------------|----------------------------|
| 1 eyepiece             | 7 mirror                   |
| 2 microscope body      | 8 target                   |
| 3 microscope objective | 9 dichroic filter          |
| 4 IOL                  | 10 condenser lens system   |
| 5 3,0 mm aperture      | 11 light source            |
| 6 collimator doublet   | 12 retro-reflecting mirror |

**Figure A.1 — Optical bench with IOL**

**A.3.3.5** Calculate the longitudinal spherical aberration (*LSA*) as the vector from the paraxial focal point to the intersection of a meridional ray at the pupillary margin with the optical axis, and determine the defocus (*Def*) caused by spherical aberration.

$$-Def = -LSA / 2 \quad (A.5)$$

where *LSA* is the longitudinal spherical aberration, expressed in millimetres. This is the vector from the back paraxial focal point to the intersection of a meridional ray at the pupillary margin with the optical axis.

NOTE 1 The user of this standard is referred to the optics literature<sup>[4]</sup> for methods on how to calculate *LSA*.

NOTE 2 It is permissible under this standard to calculate *Def* by other procedures, such as those available in optical design calculation programmes and raytrace software, provided that the correctness of the programme has been verified.

NOTE 3 *Def* is a vector that can be positive or negative. The quantity *-Def* is added to *BFL* (or *EFL*) as a correction.

**A.3.3.6** If *BFL* is measured calculate *EFL* as follows:

$$EFL = BFL - A_2 H'' \quad (A.6)$$

Calculate the paraxial focal length:

$$f = EFL - Def \quad (A.7)$$

**A.3.3.7** Paraxial focal length, *f* (in metres), is converted to dioptric power, *D* (in reciprocal metres), by using the Equation:

$$D = n_{med} / f \quad (A.8)$$

where  $n_{med} = 1$ .

**A.3.3.8** Compute the conversion ratio, *Q*, using the Formula:

$$Q = D_{aq,nom} / D_{air,nom} \quad (A.9)$$

where  $D_{aq,nom}$  and  $D_{air,nom}$  are calculated from Formulae A.1, A.2 and A.3 using nominal dimensions for the IOL,  $n_{med} = 1$  and the appropriate value for  $n_{IOL}$ .

**A.3.3.9** Finally calculate the dioptric power *in situ*,  $D_{aq}$ , by using the Formula:

$$D_{aq} = D_{air} \cdot Q \quad (A.10)$$

NOTE If measurement of *BFL* (or *EFL*) is made at simulated *in situ* conditions,  $n_{med} = 1,336$  in Formulae A.2, A.3, A.4 and A.8. Formula A.8 then gives directly  $D_{aq}$ .

### A.3.4 Applicability

This method is as described applicable to rotationally symmetric spherical or aspheric IOLs.

## A.4 Determination of dioptric power from measured magnification

### A.4.1 Principle

The concept of lens power relates to the image magnification of a lens. The principle of the focal collimator to measure magnification to determine dioptric power is given here.

### A.4.2 Apparatus

An optical bench such as described in [A.3.2.1](#) with the following modifications:

- a) a target with a measurable linear dimension, such as the distance between two lines;
- b) an eye-piece with some means, such as a reticule, to measure the corresponding linear dimension in the image.

### A.4.3 Procedure

Determine the linear dimension,  $h_{\text{target}}$ , of the target.

Determine the focal length,  $F$ , of the collimator.

NOTE 1 These two determinations need not be repeated every time.

NOTE 2 The ratio  $F/h_{\text{target}}$  could be obtained by measurement of calibrated lenses in lieu of the IOL.

Mount the IOL on the optical bench just behind the 3 mm aperture.

Focus the microscope on the image and measure the linear dimension,  $h_{\text{image}}$ , in the image.

Focusing is done at a spatial frequency close to 0,3 of the cut-off frequency of the IOL.

Calculate the effective focal length ( $EFL$ ) of the IOL,  $f$ , by using the Equation:

$$EFL = \left( F / h_{\text{target}} \right) \cdot h_{\text{image}} \quad (\text{A.11})$$

Add the spherical aberration correction from Formula A.5 to  $EFL$  to obtain the paraxial focal length,  $f_{\text{air}}$ , and continue to calculate the dioptric power in air and aqueous according to Formulae A.8, A.9 and A.10.

### A.4.4 Applicability

This method as described is applicable to rotationally symmetric spherical or aspheric IOL.

### A.4.5 Precision

For monofocal IOLs, the repeatability and the reproducibility are functions of dioptric power, and are expected to be about 0,5 % and 1 %, respectively, of the dioptric power<sup>[1]</sup>.

## A.5 Determination of dioptric power and error in axis for TIOL

### A.5.1 General

The general methods [A.2](#) and [A.3](#) in this Annex are modified to allow measurement of the dioptric power in the principal meridians of highest and lowest dioptric power, and allow alignment of the measurement axis with the axis marks of the meridian of lowest dioptric power.

### A.5.2 Without the use of a null lens

For toric IOLs, the dioptric powers in the two principal meridians are determined as follows:

- a) If determined in accordance with [A.2](#): calculate the dioptric powers from measured dimensions (including radii) of the two principal meridians;
- b) If determined in accordance with [A.3](#): calculate the dioptric powers from the measured back focal lengths of the two principal meridians. The principal meridian under measurement and the applied target are aligned in such a way that a sharp image is perceived;
- c) If determined in accordance with [A.4](#): calculate the dioptric power from the measured magnification of the two principal meridians. The principal meridian under measurement and the applied target are aligned in such a way that a sharp image is perceived.

The spherical equivalent power (SE) is calculated as follows:

$$SE = (\text{dioptric power in high power meridian} + \text{dioptric power in low power meridian})/2.$$

The cylindrical power (CYL) is determined as follows:

$$CYL = \text{dioptric power in high power meridian} - \text{dioptric power in low power meridian}.$$

NOTE The methods are suitable for cylindrical powers less than 5 D.

### A.5.3 With the use of a null lens

The optical bench described in [A.3.2](#) can be modified to determine SE and CYL with the addition of a positive cylinder lens (null lens) placed behind or in front of the TIOL being tested.

The null lens is a lens that compensates for the astigmatism of the TIOL. The cylinder axis of the null lens is aligned with the principal meridian of the TIOL meridian of the highest dioptric power. The lens power and position of the null lens are chosen such that the lens combination of the null lens and the IOL creates a sharp image of the 2-dimensional target. First the lens power of the uncorrected principal meridian of the highest dioptric lens power is determined by either method in [A.3](#) or [A.4](#), and then the position of the null lens is measured. The cylinder power can then be calculated from the cylinder power of the null lens and its location relative to the TIOL principal plane of the low power meridian using the lens combination Formula (4).

### A.5.4 Determination of error in axis for TIOL

#### A.5.4.1 Determination of error in axis without a null lens

The error in the axis is determined using either of the methods [A.5.2](#) b) or c). When a best focused image is perceived, determine the angle between the target principal direction and the toric indicators. This angle is the error in the axis.

#### A.5.4.2 Determination of error in axis with a null lens

The error in the axis is determined using the method in [A.5.3](#). When a focused image is perceived, determine the angle between the cylinder axis of the null lens or its orthogonal meridian and the toric indicators of the TIOL. The smaller of these is the error in the axis.

NOTE An error of the orthogonality between the meridians of lowest and highest powers will be apparent in the imaging quality.

## A.6 Determination of dioptric power for multifocal IOL (MIOL)

Two alternative methods for the determination of dioptric power can be applied to MIOL (A.3 and A.4). Measurements are done for apertures at  $3,0 \text{ mm} \pm 0,1 \text{ mm}$ . Due to the complexity of the optic surfaces, the method described in A.2 should not be used for MIOL.

For each near image plane, these methods are modified as follows:

- a) Determination of dioptric power from measured back focal length (A.3): The microscope is first focused on the back vertex of the MIOL, and then focused on the far image plane to obtain *BFL* for the far power, and subsequently focused on the near image plane to obtain *BFL* for the near power.
- b) Determination of dioptric power from measured magnification (A.4): The microscope is first focused on the far image plane to obtain the linear dimension  $h_{\text{image}}$  for the far power, and subsequently focused on the near image plane to obtain  $h_{\text{image}}$  for the near power.

NOTE 1 Depending on the MIOL optic design the correction formulas given in this standard could be invalid. In such cases the manufacturer should derive and justify corrections that result in dioptric powers that are consistent with power labelling of monofocal IOLs.

NOTE 2 If the focusing conditions are not appropriate for the particular design, another focusing condition should be developed with justification.

NOTE 3 If the addition power of an MIOL is not centrally located; the manufacturer should justify the LSA correction factor that is used.

## A.7 Accommodating IOL (AIOL)

### A.7.1 Mode of action

Describe the accommodative mode of action in the eye and associated test methods to demonstrate that action.

### A.7.2 Determination of dioptric power

Determine dioptric power with either of the methods described in A.3 and A.4.

## Annex B (normative)

### Measurement of resolution efficiency

#### B.1 General

This annex describes the principles, apparatus and methods for resolution efficiency measurement of intraocular lenses.

#### B.2 Principle

The resolution limit of an IOL, expressed as a percentage of the diffraction limited cut-off spatial frequency of an ideal lens having the same focal length, is determined under defined conditions of aperture, surrounding medium, and wavelength. The aperture is 3,0 mm, the surrounding medium is air, and the light source has a peak wavelength within  $\pm 10$  nm of 546 nm having a full width at half maximum of 20 nm or less.

#### B.3 Apparatus

An optical bench as illustrated in [Figure A.1](#).

NOTE A modified bench (e.g. additional converging lens, a microscope objective of appropriate numerical aperture, etc.) may be needed to quantify the imaging quality of negative and low dioptric power IOLs.

#### B.4 Procedure

**B.4.1** Place the IOL on the optical bench taking care to centre it as well as possible on the optical axis of the bench.

**B.4.2** By moving the microscope objective, focus the image of the target to obtain the best possible overall balance between coarse and fine patterns (see [Figure B.1](#)).

**B.4.3** Then determine the finest pattern (group, element) for which both horizontal and vertical bars are resolved without distortion and with the additional requirement that all coarser patterns are also resolved. Refer to ISO 6328:2000, 5.3.5.1, regarding how to determine if a pattern is resolved.

#### B.5 Calculations

**B.5.1** The spatial frequency,  $\nu$ , for the finest pattern resolved is calculated from the Formula:

$$v = (F / f) \times 2^{[G+(E-1)/6]} \quad (\text{B.1})$$

where

- $G$  denotes the group of the pattern;
- $E$  denotes the element within that group of the pattern;
- $F$  is the focal length, in millimetres, of the collimator;
- $f$  is the focal length, in millimetres, of the IOL;

**B.5.2** The diffraction limited cut-off frequency,  $\omega$ , expressed in reciprocal millimetres is calculated by the Equation:

$$\omega = (2n \cdot \sin u) / \lambda \quad (\text{B.2})$$

where

- $n$  is the refractive index of the surrounding medium;
- $\lambda$  is the wavelength of the light, in millimetres;
- $u$  is the angle between the optical axis and the marginal ray.

For small angles the expression in reciprocal millimetres can be reduced to the Formula:

$$\omega = (nd) / (f\lambda) \quad (\text{B.3})$$

where  $d$  is the diameter of the aperture stop in millimetres.

**B.5.3** The resolution efficiency,  $RE$ , expressed as a percentage of the cut-off spatial frequency, is calculated from the Formula:

$$RE = 100 \times 2^{[G+(E-1)/6]} \times (F\lambda) / (nd) \quad (\text{B.4})$$

NOTE In the case under consideration  $n = 1$  (air),  $d = 3$  mm, and  $\lambda = 0,000\ 546$  mm.

#### B.5.4 Applicability

This method is as described applicable to rotationally symmetric spheric and aspheric IOLs only.

### B.6 Precision

For monofocal IOLs, the repeatability and reproducibility expected with this method are 20 % and 30 % of the cut-off frequency, respectively[2].

### B.7 Measurement of resolution efficiency for toric IOL (TIOL)

The optical bench described in [Annex A](#) is modified with the addition of a cylindrical lens (null lens) placed behind or in front of the TIOL being tested.

Alignment of the null lens' cylindrical axis is made with an axis mark on the TIOL.

### B.8 Measurement of resolution efficiency for multifocal IOL (MIOL)

Imaging quality for MIOL is generally characterized by MTF as described in [Annex C](#).

### B.9 Measurement of resolution efficiency for accommodating IOL (AIOL)

Same procedures as with monofocal IOLs apply to AIOLs.

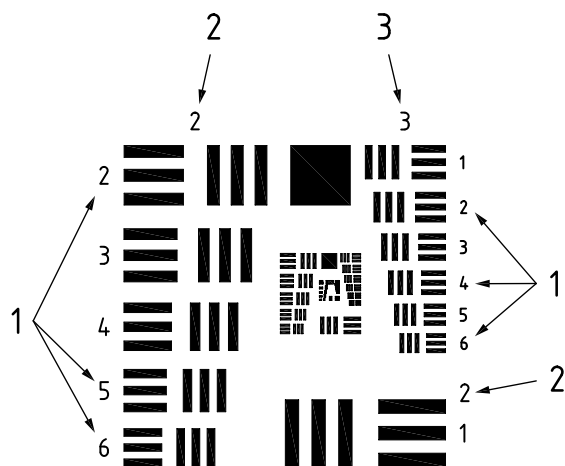

- Key**
- 1 element number
  - 2 group 2
  - 3 group 3

**Figure B.1 — U.S. Air Force 1951 Resolution Target with groups 0 and 1 omitted**

## Annex C (normative)

### Measurement of MTF

#### C.1 General

This annex describes the principles, apparatus and methods for MTF measurement of rotationally symmetric monofocal IOLs. Modifications required for other types of IOLs are provided at the end of this annex.

#### C.2 Principle

The modulation transfer function (MTF) of an IOL is measured using a model eye. A light source with a peak wavelength within  $\pm 10$  nm of 546 nm having a full width at half maximum of 20 nm or less is used.

The model eyes described in this Annex are tools for establishing quality criteria for IOLs by means of the limits set in [Clause 4.3](#). No inference should be made to performance in real eyes.

#### C.3 Apparatus

##### C.3.1 Model eye 1

Model eye 1 has the following features:

- a) the model cornea is a lens with minimal spherical aberration similar to the one described in [Table C.1](#);
- b) the IOL front surface is placed at an axial location that is between 26 mm and 28 mm in front of the focal point of the model cornea itself, taking the refractive index of the image space to be 1,336;
- c) the converging beam from the model cornea is stopped down to expose a central circular area of the IOL having a diameter appropriate for the test to a tolerance of  $\pm 0,1$  mm;
- d) the IOL is placed in a liquid medium contained between two flat windows;
- e) the difference in refractive index between the IOL and the liquid medium is within 0,005 units of that under *in situ* conditions;
- f) the image plane falls in air, beyond the last window.

A possible realization of Model eye 1 is illustrated in [Figure C.1](#) and described in [Table C.1](#). Many other realizations are possible.

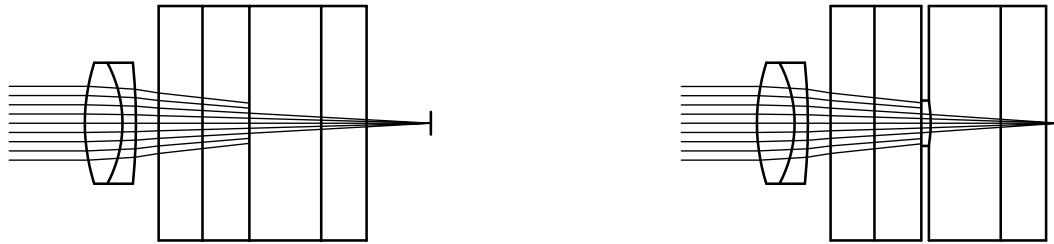

a) Without IOL (as described in [Table C.1](#))

b) With a 30 D spherical IOL in place (Note that the image plane moves closer to the last window, but remains behind it.)

**Figure C.1 — Model eye 1 configuration**

**Table C.1 — Description of a model eye (with 3 mm aperture at surface 6) fulfilling the requirements of [C.3.1](#)**

Surface number	Surface radius mm	Separation space mm	Diameter mm	Refractive index
1	24,590	5,21	16	1,620
2	- 15,580	1,72	16	1,694
3	- 90,200	3,0	16	1,000
4	∞	6,0	32	1,519
5	∞	6,25	32	1,336
6	∞	10,0	3,0	1,336
7	∞	6,0	32	1,519
8	∞	9,25	32	1,000
9	image plane (∞)			

The model cornea (surfaces 1–3) is a so-called achromat. The one described here is no longer commercially available, but a model eye that fulfils the description in [C.3.1](#) can be built with similar commercially available achromats. The choice of glass for the windows (surfaces 4 and 7) is not critical.

**C.3.2 Model eye 2**

Model eye 2 has the following features:

- a) the converging beam of the model cornea, when exposing a circular area of 5,15 mm ± 0,10 mm at an axial location that is between 26 mm and 28 mm in front of the focal point of the model cornea itself, taking the refractive index of the image space to be 1,336, produces a wavefront that is characterized by a value for the Zernike coefficient  $c(4,0)$  to within ± 0,020 μm of the intended value;
- b) the IOL front surface is placed at the axial location specified in a);
- c) the converging beam from the model cornea is stopped down to expose a central circular area of the IOL having a diameter appropriate for the test to a tolerance of ± 0,1 mm;
- d) the IOL is placed in a liquid medium contained between two flat windows;
- e) the difference in refractive index between the IOL and the liquid medium is within 0,005 units of that under *in situ* conditions;

f) the image plane falls in air, beyond the last window.

A possible realization of Model eye 2 is illustrated in [Figure C.2](#) and described in [Table C.2](#) and [C.3](#) assuming the model cornea to be made of a material with refractive index 1,493 (PMMA). Many other realizations are possible.

With the refractive index 1,493 and the thickness 10 mm for the model cornea, the asphericity,  $Q$ , of the front surface can be calculated from the Equation:

$$Q = -0,9519 \cdot [c(4,0)]^2 + 2,9567 \cdot [c(4,0)] - 0,4809 \quad (C.1)$$

for values of  $c(4,0)$  in the range from  $-0,2 \mu\text{m}$  to  $+0,5 \mu\text{m}$ .

$Q$  is defined in the Equation for a conic section:

$$z = \frac{\left(\frac{1}{R}\right)r^2}{1 + \sqrt{1 - (Q+1)\left(\frac{1}{R}\right)^2 r^2}} \quad (C.2)$$

where  $z$  is the sagittal distance from the vertex,  $r$  is the radial distance from the centre, and  $R$  is the radius of curvature of the surface.

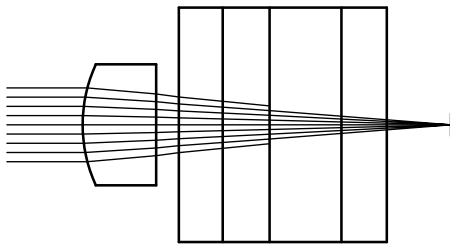

**a) Without IOL** (as described in [Table C.2](#))

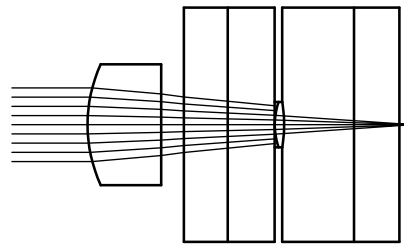

**b) With a 30 D aspheric IOL that corrects the aberration of the model cornea in place** (The central 3 mm of the IOL are exposed. Note that the image plane moves closer to the last window, but remains behind it.)

**Figure C.2 — Model eye 2 configuration**

**Table C.2 — Description of a model eye (with 5,15 mm aperture at surface 5) fulfilling the requirements of C.3.2**

Surface number	Surface radius mm	Q-value to obtain the desired Zernike coefficient c(4,0)	Separation space mm	Diameter mm	Refractive index
1	19,332	Formula C.1	10,0	16	1,493
2	∞	—	3,0	16	1,000
3	∞	—	6,0	32	1,519
4	∞	—	6,25	32	1,336
5	∞	—	10,0	5,15	1,336
6	∞	—	6,0	32	1,519
7	∞	—	9,45	32	1,000
8	image plane (∞)	—	—	—	—

The model cornea (surfaces 1-2) is assumed cut from PMMA. A model cornea that meets the description in C.3.2 can be realized in many other ways and materials, but there is none commercially available. The choice of glass for the windows (surfaces 3 and 6) is not critical.

**Table C.3 — Example of surface number 1 Q-values calculated by Formula C.1 to obtain selected c(4,0) values**

c(4,0)	0,000 μm	0,100 μm	0,200 μm	0,280 μm
Q	-0,481	-0,195	0,072	0,272

NOTE 1 A value of 0,280 μm for the Zernike coefficient (4,0) is described in Reference [8] for an average human eye with a 6 mm entrance pupil.

NOTE 2 The cornea of the Liou and Brennan model eye[9] provides a value of 0,258 μm for c(4,0) for an entrance pupil of 6 mm, and exposes the central 5,15 mm at the plane of the front surface of its lens, with a theoretical paraxial focus 26,3 mm behind that plane in a medium of refractive index 1,336.

NOTE 3 Model eye 1 and Model eye 2 are suitable only for an object at infinity. For objects at finite distances it is not adequate because the magnification is not comparable to that of the natural eye. A model eye with physiological dimensions is needed. A practical realization is given in Reference [10].

NOTE 4 Model eye 2 is recommended as an alternative model that can be used for MTF testing for lenses that are intended to have a certain amount of spherical aberration[10]. Several additional examples are shown.

NOTE 5 The notation for Zernike coefficients follows ISO 24157[11].

### C.3.3 Optical bench

The model eye is mounted on an optical bench for measurement of MTF conforming to the requirements of ISO 9335.

With the apparatus described, measurement can be carried out at ambient temperature if the IOL dimensions or optical performance do not deviate appreciably from those under *in situ* conditions. Otherwise the measurement is carried out at simulated *in situ* conditions.

### C.4 Procedure

Place the model eye (C.3.1 or C.3.2) on the optical bench (C.3.3). Ensure that the IOL is in the correct position, and that the model eye is well aligned with the optical axis of the bench, and focused to obtain maximum MTF at 50 mm<sup>-1</sup>. Record the MTF values at the required spatial frequencies.

## C.5 Precision

For monofocal IOLs in the range of 10 D to 30 D, the repeatability and reproducibility expected with this method is 0,09 and 0,19 modulation units, respectively in Reference [2].

## C.6 Measurement of MTF for toric IOL (TIOL)

For TIOL, MTF is measured in the meridians of highest and lowest dioptric power.

Alternatively, use a null lens to permit MTF measurement as a rotationally symmetric IOL.

## C.7 Measurement of MTF for multifocal IOL (MIOL)

This testing will confirm that the actual performance of the lens is similar to its theoretical performance. Use 10 representative samples each of low, medium and high dioptric power MIOL for testing in a model eye: The choice of the model eye is to be justified by the manufacturer. A total of 30 lenses (10 low, 10 medium, and 10 high power) are used for the on axis condition, and a total of 3 lenses (1 low, 1 medium, and 1 high power) are used for the decentred and tilted conditions. In each case, the performance is compared to that of a similar monofocal optic lens design.

### a) Modulation Transfer Function (MTF) testing:

Generate MTF through-frequency curves of the far power and of each near power (or power range) with the lens on-axis. Use aperture sizes 2 mm, 3 mm and 4,5 or 5 mm ( $\pm 0,1$  mm) at the position of the lens.

Focus to give maximum modulation ratio for  $50 \text{ mm}^{-1}$  in each case. Report the results in the form of graphs averaging MTF on-axis curves for each power tested.

Individual MIOLs representing the median performance for the on-axis condition from the low, medium and high power groups are used for the subsequent decentred and tilted conditions.

Generate MTF through-frequency curves for the images formed by the far and by each near power (or power range) with the selected MIOL under the following conditions: 1) decentred at 1,0 mm, and 2) tilted  $5^\circ$ . Use aperture sizes 2 mm, 3 mm, and 4,5 or 5 mm ( $\pm 0,1$  mm) at the position of the lens.

### b) MTF through-focus-response testing:

Generate the MTF through-focus-response of the MIOL at  $50 \text{ mm}^{-1}$  with 2 mm, 3 mm, and 4,5 mm or 5 mm  $\pm 0,1$  mm apertures. Focus to maximum MTF at  $50 \text{ mm}^{-1}$  for an object at infinity and then measure MTF at positions more posterior in image space using 0,1 mm steps up to 1,5 mm.

NOTE It can be necessary to have a different imaging quality specification for each combination of test aperture and focus.

## C.8 Measurement of MTF for accommodating IOL (AIOL)

### a) Modulation transfer function (MTF) testing:

Generate MTF through-frequency response curves at 3 mm aperture at the far power configuration and configurations associated with the designed range of accommodation in 0,5 D or smaller increments;

### b) MTF through-focus-response testing:

Generate the MTF through-focus response of the AIOL at  $50 \text{ mm}^{-1}$  with 3 mm ( $\pm 0,1$  mm) aperture at the far power configuration. Focus to maximum MTF at  $50 \text{ mm}^{-1}$  for an object at infinity and then measure MTF at positions more posterior in image space using 0,1 mm steps up to 1,5 mm.

## Bibliography

- [1] NORRBY NE, GROSSMAN LW, GERAGHTY EP, et al. Accuracy in determining intraocular lens dioptric power assessed by interlaboratory tests. *J. Cataract Refract. Surg.* 1996, **22** (7) pp. 983–993
- [2] NORRBY NE, GROSSMAN LW, GERAGHTY EP, et al. Determining the imaging quality of intraocular lenses. *J. Cataract Refract. Surg.* 1998, **24** (5) pp. 703–714
- [3] ISO 18369-3:2006, *Ophthalmic optics — Contact lenses — Part 3: Measurement methods*
- [4] SMITH WJ. *Modern Optical Engineering*. McGraw-Hill, New York, Fourth Edition, 2008
- [5] HUANG Y, ZHANG K, KANG J, CALOGERO D, JAMES R, ILEV I Noncontact common path Fourier domain optical coherence tomography method for in vitro intraocular lens power measurement. *Journal of Biomedical Optics*, 2011, 16(12).126005
- [6] ISO 18369-4:2006, *Ophthalmic optics — Contact lenses — Part 4: Physicochemical properties of contact lens materials*
- [7] U.S. Mil Std 150-A-1961, Photographic lenses, §5.1.1.7
- [8] WANG L, & DAI E, KOCH DD, NATHOO A Optical aberrations of the human anterior cornea. *J. Cataract Refract. Surg.* 2003, **29** (8) pp. 1514–1521
- [9] LIOU HL, & BRENNAN NA Anatomically accurate, finite model eye for optical modeling. *J. Opt. Soc. Am.* 1997, **14** (8) pp. 1684–1695
- [10] NORRBY NE, & PIERS P, CAMPBELL C, VAN DER MOOREN. M Model eyes for evaluation of intraocular lenses. *Appl. Opt.* 2007, **46** pp. 6595–6605
- [11] ISO 24157:2008, *Ophthalmic optics and instruments — Reporting aberrations of the human eye*



