

**INTERNATIONAL
STANDARD**

**IEC
60601-2-4**

Second edition
2002-08

Medical electrical equipment –

**Part 2-4:
Particular requirements for the safety
of cardiac defibrillators**

Appareils électromédicaux –

*Partie 2-4:
Règles particulières de sécurité
pour les défibrillateurs cardiaques*



Reference number
IEC 60601-2-4:2002(E)

Publication numbering

As from 1 January 1997 all IEC publications are issued with a designation in the 60000 series. For example, IEC 34-1 is now referred to as IEC 60034-1.

Consolidated editions

The IEC is now publishing consolidated versions of its publications. For example, edition numbers 1.0, 1.1 and 1.2 refer, respectively, to the base publication, the base publication incorporating amendment 1 and the base publication incorporating amendments 1 and 2.

Further information on IEC publications

The technical content of IEC publications is kept under constant review by the IEC, thus ensuring that the content reflects current technology. Information relating to this publication, including its validity, is available in the IEC Catalogue of publications (see below) in addition to new editions, amendments and corrigenda. Information on the subjects under consideration and work in progress undertaken by the technical committee which has prepared this publication, as well as the list of publications issued, is also available from the following:

- **IEC Web Site (www.iec.ch)**
- **Catalogue of IEC publications**
The on-line catalogue on the IEC web site (http://www.iec.ch/searchpub/cur_fut.htm) enables you to search by a variety of criteria including text searches, technical committees and date of publication. On-line information is also available on recently issued publications, withdrawn and replaced publications, as well as corrigenda.
- **IEC Just Published**
This summary of recently issued publications (http://www.iec.ch/online_news/justpub/ip_entry.htm) is also available by email. Please contact the Customer Service Centre (see below) for further information.
- **Customer Service Centre**
If you have any questions regarding this publication or need further assistance, please contact the Customer Service Centre:

Email: custserv@iec.ch
Tel: +41 22 919 02 11
Fax: +41 22 919 03 00

INTERNATIONAL STANDARD

IEC
60601-2-4

Second edition
2002-08

Medical electrical equipment –

Part 2-4: Particular requirements for the safety of cardiac defibrillators

Appareils électromédicaux –

Partie 2-4: Règles particulières de sécurité pour les défibrillateurs cardiaques

© IEC 2002 — Copyright - all rights reserved

No part of this publication may be reproduced or utilized in any form or by any means, electronic or mechanical, including photocopying and microfilm, without permission in writing from the publisher.

International Electrotechnical Commission, 3, rue de Varembé, PO Box 131, CH-1211 Geneva 20, Switzerland
Telephone: +41 22 919 02 11 Telefax: +41 22 919 03 00 E-mail: inmail@iec.ch Web: www.iec.ch



Commission Electrotechnique Internationale
International Electrotechnical Commission
Международная Электротехническая Комиссия

PRICE CODE

U

For price, see current catalogue

CONTENTS

FOREWORD	4
INTRODUCTION	6
SECTION ONE – GENERAL	
1 Scope and object	7
2 Terminology and definitions.....	8
4 General requirements for tests	11
*5 Classification	11
6 Identification, marking and documents.....	11
SECTION TWO – ENVIRONMENTAL CONDITIONS	
10 Environmental conditions	16
SECTION THREE – PROTECTION AGAINST ELECTRIC SHOCK HAZARDS	
14 Requirements related to classification	16
*17 Separation	16
19 Continuous LEAKAGE CURRENTS and PATIENT AUXILIARY CURRENTS.....	18
*20 Dielectric strength	19
SECTION FOUR – PROTECTION AGAINST MECHANICAL HAZARDS	
SECTION FIVE – PROTECTION AGAINST HAZARDS FROM UNWANTED OR EXCESSIVE RADIATION	
*36 Electromagnetic compatibility (EMC)	21
SECTION SIX– PROTECTION AGAINST HAZARDS OF IGNITION OF FLAMMABLE ANAESTHETIC MIXTURES	
SECTION SEVEN – PROTECTION AGAINST EXCESSIVE TEMPERATURES AND OTHER SAFETY HAZARDS	
*42 Excessive temperatures	24
44 Overflow, spillage, leakage, humidity, ingress of liquids, cleaning, sterilization, disinfection and compatibility.....	24
46 Human errors.....	25
SECTION EIGHT – ACCURACY OF OPERATING DATA AND PROTECTION AGAINST HAZARDOUS OUTPUT	
*50 Accuracy of operating data	26
51 Protection against hazardous output.....	26

**SECTION NINE – ABNORMAL OPERATION AND FAULT CONDITIONS;
ENVIRONMENTAL TESTS**

52 Abnormal operation and fault conditions	27
--	----

SECTION TEN – CONSTRUCTIONAL REQUIREMENTS

*56 Components and general assembly	27
57 MAINS PARTS, components and layout	29

SECTION 101 – ADDITIONAL REQUIREMENTS RELATING TO SAFETY

*101 Charging time	29
102 Internal electrical power source	32
*103 Endurance	34
*104 Synchronizer	35
*105 Recovery of the MONITOR/ECG INPUT after defibrillation	35
*106 Disturbance to the monitor from charging or internal discharging	36

Appendix L References – Publications mentioned in this Standard	43
Annex AA (informative) General guidance and rationale	44
Annex BB (informative) AUTOMATED EXTERNAL DEFIBRILLATORS: background and rationale	54

INTERNATIONAL ELECTROTECHNICAL COMMISSION

MEDICAL ELECTRICAL EQUIPMENT –

Part 2-4: Particular requirements for the safety of cardiac defibrillators

FOREWORD

- 1) The IEC (International Electrotechnical Commission) is a worldwide organization for standardization comprising all national electrotechnical committees (IEC National Committees). The object of the IEC is to promote international co-operation on all questions concerning standardization in the electrical and electronic fields. To this end and in addition to other activities, the IEC publishes International Standards. Their preparation is entrusted to technical committees; any IEC National Committee interested in the subject dealt with may participate in this preparatory work. International, governmental and non-governmental organizations liaising with the IEC also participate in this preparation. The IEC collaborates closely with the International Organization for Standardization (ISO) in accordance with conditions determined by agreement between the two organizations.
- 2) The formal decisions or agreements of the IEC on technical matters express, as nearly as possible, an international consensus of opinion on the relevant subjects since each technical committee has representation from all interested National Committees.
- 3) The documents produced have the form of recommendations for international use and are published in the form of standards, technical specifications, technical reports or guides and they are accepted by the National Committees in that sense.
- 4) In order to promote international unification, IEC National Committees undertake to apply IEC International Standards transparently to the maximum extent possible in their national and regional standards. Any divergence between the IEC Standard and the corresponding national or regional standard shall be clearly indicated in the latter.
- 5) The IEC provides no marking procedure to indicate its approval and cannot be rendered responsible for any EQUIPMENT declared to be in conformity with one of its standards.
- 6) Attention is drawn to the possibility that some of the elements of this International Standard may be the subject of patent rights. The IEC shall not be held responsible for identifying any or all such patent rights.

International Standard IEC 60601-2-4 has been prepared by sub-committee 62D: Electro-medical equipment, of IEC technical committee 62: Electrical equipment in medical practice.

This second edition of IEC 60601-2-4 cancels and replaces the first edition published in 1983 of which it constitutes a technical revision.

The text of this standard is based on the following documents:

FDIS	Report on voting
62D/455/FDIS	62D/460/RVD

Full information on the voting for the approval of this standard can be found in the report on voting indicated in the above table.

Annexes AA and BB are for information only.

In this Particular Standard the following print types are used:

- requirements, compliance with which can be tested, and definitions: roman type;
- notes, explanations, advice, introductions, general statements, exceptions and references: smaller type;
- *test specifications, headings of subclauses and headings of items: italic type;*
- TERMS DEFINED IN CLAUSE 2 OF THE GENERAL STANDARD OR THIS PARTICULAR STANDARD: SMALL CAPITALS.

The committee has decided that the contents of this publication will remain unchanged until 2007-08. At this date, the publication will be

- reconfirmed;
- withdrawn;
- replaced by a revised edition, or
- amended.

INTRODUCTION

This Particular Standard concerns the safety of CARDIAC DEFIBRILLATORS. It amends and supplements IEC 60601-1 (second edition, 1988): *Medical electrical equipment – Part 1: General requirements for safety*, including its amendments 1 (1991) and 2 (1995), hereinafter referred to as the General Standard.

A first edition of this Particular Standard, based on the first edition (1977) of IEC 60601-1 was published in 1983. The aim of this second edition is to bring this Particular Standard up to date with reference to the publications and documents mentioned above through minor changes to the technical content.

The requirements are followed by specifications for the relevant tests.

A rationale for the more important requirements, where appropriate, is given in Annex AA. It is considered that a knowledge of the reasons for these requirements will not only facilitate the proper application of this Particular Standard but will, in due course, expedite any revision necessitated by changes in clinical practice or as a result of developments in technology. However this annex does not form part of the requirements of this standard.

Clauses and subclauses for which a corresponding rationale statement is given in Annex AA are marked with an asterisk * before their number in the text.

MEDICAL ELECTRICAL EQUIPMENT

Part 2: Particular requirements for the safety of cardiac defibrillators

SECTION ONE – GENERAL

The clauses and subclauses of this section of the General Standard apply except as follows:

1 Scope and object

This clause of the General Standard applies except as follows:

*1.1 Scope

Addition:

This Particular Standard specifies requirements for the safety of CARDIAC DEFIBRILLATORS as defined in 2.1.101, hereinafter referred to as EQUIPMENT.

This Particular Standard does not apply to implantable defibrillators, remote control DEFIBRILLATORS, external transcutaneous pacemakers, or separate stand alone CARDIAC MONITORS (which are standardized by IEC 60601-2-27). Cardiac monitors which use separate ECG monitoring electrodes are not within the scope of this standard unless they are used as the sole basis for AED rhythm recognition detection or beat detection for synchronized cardioversion.

Defibrillation waveform technology is evolving rapidly. Published studies indicate that the effectiveness of waveforms varies. The choice of a particular waveform including waveshape, delivered energy, efficacy, and safety has been specifically excluded from the scope of this standard.

However, due to the critical importance of the therapeutic waveform, comments have been added to the rationale which address considerations in waveform selection.

1.2 Object

Replacement:

The object of this Particular Standard is to establish particular requirements for the safety of CARDIAC DEFIBRILLATORS as defined in 2.1.101.

1.3 Particular Standards

Addition:

This Particular Standard refers to IEC 60601-1 (1988): *Medical electrical equipment – Part 1: General requirements for safety* as amended by its amendment 1 (1991) and amendment 2 (1995).

For brevity, Part 1 is referred to in this Particular Standard either as the "General Standard" or as the "General Requirement(s)".

The numbering of sections, clauses and subclauses of this Particular Standard corresponds with that of the General Standard. The changes to the text of the General Standard are specified by the use of the following words:

“Replacement” means that the clause or subclause of the General Standard is replaced completely by the text of this Particular Standard.

“Addition” means that the text of this Particular Standard is additional to the requirements of the General Standard.

“Amendment” means that the clause or subclause of the General Standard is amended as indicated by the text of this Particular Standard.

Subclauses or figures which are additional to those of the General Standard are numbered starting from 101, additional annexes are lettered AA, BB, etc., and additional items aa), bb), etc.

The term “this Standard” is used to make reference to the General Standard and this Particular Standard taken together.

Where there is no corresponding section, clause or subclause in this Particular Standard, the section, clause or subclause of the General Standard, although possibly not relevant, applies without modification.

Where it is intended that any part of the General Standard, although possibly relevant, is not to be applied, a statement to that effect is given in this Particular Standard.

The requirements of this Particular Standard take priority over those of the General Standard.

1.5 Collateral Standards

Addition:

The following Collateral Standards apply:

IEC 60601-1-1:2000, *Medical electrical equipment – Part 1-1: General requirements for safety – Collateral standard: Safety requirements for medical electrical systems*

IEC 60601-1-2:2001, *Medical electrical equipment – Part 1-2: General requirements for safety – Collateral standard: Electromagnetic compatibility – Requirements and tests*

IEC 60601-1-4:1996, *Medical electrical equipment – Part 1: General requirements for safety – 4. Collateral Standard: Programmable electrical medical systems*

2 Terminology and definitions

This clause of the General Standard applies except as follows:

Additional definitions:

2.1.101

CARDIAC DEFIBRILLATOR

MEDICAL ELECTRICAL EQUIPMENT intended to defibrillate the heart by an electrical pulse via electrodes applied either to the PATIENT's skin (external electrodes) or to the exposed heart (internal electrodes). May be referred to as DEFIBRILLATOR or EQUIPMENT

NOTE Such EQUIPMENT may also include other monitoring or therapeutic functions.

2.1.102**MONITOR**

part of a DEFIBRILLATOR providing a visual display of the electrical activity of the PATIENT's heart

NOTE The term is used within this Particular Standard to distinguish such a MONITOR from one which forms a separate EQUIPMENT in its own right even in cases where the separate stand-alone monitor is able to provide synchronization signals to the DEFIBRILLATOR, used as basis for AED rhythm recognition detection or providing control signals to the DEFIBRILLATOR.

2.1.103**CHARGING CIRCUIT**

circuit within the DEFIBRILLATOR intended for charging the ENERGY STORAGE DEVICE. This circuit includes all parts conductively connected to the ENERGY STORAGE DEVICE during the charging period

2.1.104**DEFIBRILLATOR ELECTRODES**

electrodes intended to deliver an electrical pulse to the PATIENT for the purpose of cardiac defibrillation

NOTE DEFIBRILLATOR ELECTRODES may also provide other monitoring (e.g. ECG acquisition) or therapeutic (e.g. transcutaneous pacing) functions and may be disposable or reusable.

2.1.105**DISCHARGE CIRCUIT**

circuit within the DEFIBRILLATOR which connects the ENERGY STORAGE DEVICE to the DEFIBRILLATOR ELECTRODES. This circuit includes all switching connections between that device and the DEFIBRILLATOR ELECTRODES

2.1.106**DISCHARGE CONTROL CIRCUIT**

circuit including the manually operated discharge controls and all parts conductively connected to them

2.1.107**INTERNAL DISCHARGE CIRCUIT**

circuit within the DEFIBRILLATOR which discharges the ENERGY STORAGE DEVICE without energizing the DEFIBRILLATOR ELECTRODES

2.1.108**SYNCHRONIZER**

device allowing the DEFIBRILLATOR discharge to be synchronized with a specific phase of the cardiac cycle

2.1.109**AUTOMATED EXTERNAL DEFIBRILLATOR (AED)**

a DEFIBRILLATOR that, once activated by the OPERATOR, analyses the ECG obtained from electrodes placed on the chest surface, identifies shockable cardiac rhythms, and automatically operates the DEFIBRILLATOR when a shockable rhythm is detected, hereinafter referred to as an AED

NOTE AEDs may provide varying levels of automation and be referred to by various terms. See Annex BB.

2.1.110**ENERGY STORAGE DEVICE**

the component (for example a capacitor) that is charged with the energy necessary to deliver an electrical defibrillation pulse to the PATIENT

2.1.111

SEPARATE MONITORING ELECTRODES

electrodes applied to the PATIENT for the purpose of monitoring the PATIENT. These electrodes are not used to apply defibrillation pulses to the PATIENT

2.1.112

RHYTHM RECOGNITION DETECTOR (RRD)

a system that analyzes the ECG and identifies whether a cardiac rhythm is shockable. The algorithm in an AED is designed for sensitivity and specificity for the detection of arrhythmias for which a defibrillation shock is clinically indicated. May be referred to as RRD

2.12.101

DELIVERED ENERGY

energy which is delivered through the DEFIBRILLATOR ELECTRODES and dissipated in the PATIENT or in a resistance of specified value

2.12.102

STAND-BY

mode of operation in which the EQUIPMENT is operational except that the ENERGY STORAGE DEVICE is not yet charged

2.12.103

STORED ENERGY

energy which is stored in the DEFIBRILLATOR ENERGY STORAGE DEVICE

2.12.104

DUMMY COMPONENT

test replacement for moulded components like transformers, semiconductors etc. The DUMMY COMPONENT has a geometry equal to that of the component it will replace during the test. The moulded volume does not incorporate parts of the original components (ex-semiconductor dye, transformer cores and windings). The DUMMY COMPONENT makes it possible to test creepage, clearance and dielectric strength with the correct geometry without exceeding the internal maximum voltage of the part being replaced

2.12.105

ENERGY METER / DEFIBRILLATOR TESTER

an INSTRUMENT capable of measuring the energy output from a CARDIAC DEFIBRILLATOR while generating a simulated ECG output to the CARDIAC DEFIBRILLATOR

2.12.106

SELECTED ENERGY

energy which the defibrillator is intended to deliver, as determined by the setting of a manual control or by an automatic protocol

2.12.107

FREQUENT USE

term used to describe a DEFIBRILLATOR designed to endure more than 2 500 discharges (see 103)

2.12.108

INFREQUENT USE

term used to describe a DEFIBRILLATOR designed to endure less than 2 500 discharges (see 103)

2.12.109

MANUAL DEFIBRILLATOR

DEFIBRILLATOR capable of being manually operated by the OPERATOR for selection of energy, charging and discharging

4 General requirements for tests

This clause of the General Standard applies except as follows:

*4.5 Ambient temperature, humidity, atmospheric pressure

Additional item:

aa) *The test required in 102.2 and 102.3 shall be performed at an ambient temperature of $0\text{ }^{\circ}\text{C} \pm 2\text{ }^{\circ}\text{C}$.*

4.6 Other conditions

Additional item:

aa) *Unless otherwise specified in this Standard all tests apply to all kinds of defibrillator types (manual, AED's, infrequent use and frequent use defibrillators)*

4.11 Sequence

Addition:

The endurance test required in Clause 103 shall be performed after the test for excessive temperatures (see Clause C.20 of the General Standard).

The tests required in Clauses 101, 102, 104, 105 and 106 shall be performed after test C.35 of Appendix C of the General Standard.

*5 Classification

This clause of the General Standard applies except as follows:

5.2 According to the degree of protection against electric shock:

Amendment:

Delete TYPE B APPLIED PART.

6 Identification, marking and documents

This clause of the General Standard applies except as follows:

6.1 Marking on the outside of *EQUIPMENT* or *EQUIPMENT* parts

*j) Power input

Replacement (paragraph beginning "If the rating of EQUIPMENT includes ..."):

The RATED power input of mains operated EQUIPMENT shall be the maximum value attained by averaging the power input over any period of 2 s.

Additional items:

***aa) Concise operating instructions**

Instructions for defibrillating, and where relevant, monitoring a PATIENT'S ECG, shall be provided by means of either clearly legible markings, or clearly understandable auditory commands.

Compliance shall be checked by either of the following tests:

Markings shall be clearly legible to a person of normal vision from a distance of 1 m in an ambient illumination of 100 lux. The observer shall have a visual acuity of not less than 20/40 or corrected to not less than 20/40 as determined by a standard eye chart or by other appropriate means, such as the Titmus Vision Test Series.

Auditory commands shall be clearly understandable to a person of normal hearing from a distance of 1 m in an ambient white noise (defined as flat $\pm 10\%$ over the range 100 Hz to 10 kHz) level of 65 dB, as measured with a Type 2 A-weighted sound level meter (see IEC 60651).

***bb) Internally powered EQUIPMENT**

INTERNALLY POWERED EQUIPMENT and any separate battery charger shall be marked with brief instructions for, as appropriate, the re-charging or replacement of the battery.

In the case of such EQUIPMENT also capable of connection to the SUPPLY MAINS or to a separate battery charger, the EQUIPMENT shall be marked to indicate any limitations of operation when the EQUIPMENT is connected to the SUPPLY MAINS or to the battery charger. Such instructions shall include the case of a discharged or missing battery.

cc) Disposable DEFIBRILLATOR electrodes

The labeling accompanying the electrode package shall include, at a minimum, the following information:

- 1) symbols (in accordance with ISO 15223) or a statement indicating the date the electrodes will expire (e.g., "use before ____") and the lot number or the date of manufacture;*
- 2) appropriate cautions and warnings, including limits on duration of electrode application and a caution that the unit package shall not be opened until immediately prior to use, if applicable;*
- 3) appropriate instructions for use, including procedures for skin preparation;*
- 4) instructions concerning storage requirements, if applicable.*

6.3 Marking of controls and INSTRUMENTS

Additional items:

***aa) The DEFIBRILLATOR shall be provided with a control for selection of the SELECTED ENERGY, unless the EQUIPMENT provides an automatic protocol for the SELECTED ENERGY.**

The SELECTED ENERGY (including any means for selection in a programming mode/menu) or the relevant indicating means shall be expressed as the nominal DELIVERED ENERGY in joules to a resistive load of 50 Ω .

The DEFIBRILLATOR shall give a clear indication of when the SELECTED ENERGY has been reached.

Compliance shall be checked by inspection.

6.8 Accompanying documents

6.8.2 Instructions for use

* items e), f), g), and h)

Replacement:

e) through h)

- e) full details of the charging procedure for any rechargeable battery;
- f) advice on the periodic replacement of any primary or rechargeable battery;
- g) the number of maximum energy discharges (in the case of AEDs, the number of preprogrammed discharges) which are available from a new and fully charged battery at 20 °C ambient temperature;
- h) for EQUIPMENT also capable of connection to the SUPPLY MAINS or to a separate battery charger, information on any limitations of operation when such a connection is made. This information shall include the case of a discharged or missing battery.

Additional item:

aa) *Supplementary instructions for use*

The instructions for use shall additionally contain the following:

- *1) a warning not to touch the PATIENT during defibrillation;
- *2) a description of the correct type and method of handling the DEFIBRILLATOR ELECTRODES in use as well as a prominent warning that DEFIBRILLATOR ELECTRODES shall be kept well clear of other electrodes or metal parts in contact with the PATIENT. The OPERATOR shall be advised that other MEDICAL ELECTRICAL EQUIPMENT which has NO DEFIBRILLATION-PROOF applied parts shall be disconnected from the PATIENT during defibrillation;
- 3) advice for the OPERATOR to avoid contact between parts of the PATIENT's body such as exposed skin of head or limbs, conductive fluids such as gel, blood or saline and metal objects such as a bed frame or a stretcher which may provide unwanted pathways for the defibrillating current;.
- *4) any environmental limitations regarding storing the EQUIPMENT (e.g. in a car or an ambulance under severe climatic conditions) immediately prior to use;
- 5) where means are provided for monitoring via SEPARATE MONITORING ELECTRODES, instructions for the placement of these electrodes;
- *6) a recommendation calling the OPERATOR'S attention to the need for periodic maintenance of the EQUIPMENT irrespective of usage, especially:
 - cleaning of any reusable DEFIBRILLATOR ELECTRODES and the insulating parts of the handles;
 - sterilization procedures for any reusable DEFIBRILLATOR ELECTRODES or handles, including recommended sterilization methods and maximum sterilization cycles, if applicable;
 - cleaning of any reusable monitoring electrodes;
 - inspection of the packaging of any disposable DEFIBRILLATOR ELECTRODES and any disposable monitoring electrodes to ensure integrity of any seals and validity of any expiry date;
 - inspection of cables and electrode handles for possible defects;
 - functional checks;
 - charging of the ENERGY STORAGE DEVICE, if it is of a type requiring periodic charging (e.g. electrolytic or polyvinylidene fluoride (PVDF) capacitors);

- *7) information on the time for charging the fully discharged ENERGY STORAGE DEVICE, when the DEFIBRILLATOR is set to maximum energy,
 - a) with RATED MAINS VOLTAGE and, for an INTERNALLY POWERED DEFIBRILLATOR, with a new fully charged battery;
 - b) as a), but for a MAINS VOLTAGE of 90 % of the RATED value and for an INTERNALLY POWERED DEFIBRILLATOR after 15 maximum energy discharges FOR FREQUENT USE DEFIBRILLATOR or 6 discharges for INFREQUENT USE DEFIBRILLATOR;
 - c) as b) but measured from initially switching power on to charge ready at maximum energy.
- 8) for AEDs, information on the maximum time from the initiation of rhythm analysis to readiness for discharge,
 - a) with RATED MAINS VOLTAGE and, for an INTERNALLY POWERED DEFIBRILLATOR, with a new fully charged battery;
 - b) as a), but for a MAINS VOLTAGE of 90 % of the RATED value and for AN INTERNALLY POWERED DEFIBRILLATOR after 15 maximum energy discharges for a FREQUENT USE DEFIBRILLATOR or 6 discharges for an INFREQUENT USE DEFIBRILLATOR.
 - c) as b) but measured from initially switching power on to charge ready at maximum energy;
- 9) for AEDs, information on whether or not the RHYTHM RECOGNITION DETECTOR will continue analyzing the ECG after the RRD has detected a shockable rhythm and the DEFIBRILLATOR is charged and ready to shock and in this case bring the AED into a state where defibrillation is prohibited;
- 10) a warning that use of a DEFIBRILLATOR in the presence of flammable agents or in an oxygen enriched atmosphere presents an explosion and fire hazard.
- 11) For EQUIPMENT intended for INFREQUENT USE, the intent shall be clearly stated and the limitations of the EQUIPMENT shall be clearly defined. Recommended or required status tests or preventive maintenance shall also be stated.
- 12) For EQUIPMENT that delivers energy according to a preset protocol, information regarding the automatic selection of DELIVERED ENERGY and the conditions for resetting of the protocol shall be described in the instructions for use. The instruction for use shall also contain information of how to change the protocol if applicable.

6.8.3 Technical description

Additional item:

- *aa) The technical description shall additionally provide:
 - 1) essential performance data for defibrillation:
 - a) graphical plots in terms of time and current or voltage of the waveforms of the delivered pulses when the DEFIBRILLATOR is connected in turn to resistive loads of 25 Ω , 50 Ω , 75 Ω , 100 Ω , 125 Ω 150 Ω and 175 Ω and set to its maximum output, or according to an automatic protocol for the SELECTED ENERGY if applicable;
 - b) energy accuracy specifications for the DELIVERED ENERGY in a 50 Ω resistor;
 - c) if the DEFIBRILLATOR has a mechanism to inhibit its output when the PATIENT impedance is outside certain limits, disclosure of those limits;
 - 2) essential performance data of any SYNCHRONIZER, including:
 - a) the meaning of any displayed synchronization or marker pulse,
 - b) the maximum time delay between the synchronization pulse and delivery of the energy, once the output has been activated, including details of how the time delay was measured, and
 - c) a statement concerning any conditions which will de-select the synchronized mode;

3) essential performance data of the RHYTHM RECOGNITION DETECTOR, including:

a) ECG Database Test Report

The ECG database for validation of rhythm recognition performance shall include, at a minimum, ventricular fibrillation (VF) rhythms of varying amplitudes, ventricular tachycardia (VT) rhythms of varying rates and QRS width, various sinus rhythms including supraventricular tachycardias, atrial fibrillation and atrial flutter, sinus rhythm with PVC (premature ventricular contraction), asystole and pacemaker rhythms. All rhythms shall have been collected using electrode systems and ECG signal processing characteristics similar to the device being tested, and shall be of appropriate length to allow decisions to be made by the detector system.

A test report describing the recording methods, rhythm source, rhythm selection criteria, and annotation methods and criteria shall be available. The results of detector performance shall be reported in terms of specificity, true predictive value, sensitivity, and false positive rates, as follows:

Table 101 – Rhythm recognition detector categories

	VF and VT	All other ECG rhythms
Shock	A	B
No shock	C	D

A true positive (A) is a correct classification of a shockable rhythm. A true negative (D) is a correct classification of all rhythms for which a shock is not indicated. A false positive (B) is an organized or perfusing rhythm or asystole that has been incorrectly classified as a shockable rhythm. A false negative (C) is a VF or VT associated with cardiac arrest that has been incorrectly classified as non-shockable.

The sensitivity of the device for shockable rhythms is $A/(A+C)$. The true predictive value is expressed as $A/(A+B)$. The specificity of the device for non-shockable rhythms is $D/(B+D)$. The false positive rate is expressed as $B/(B+D)$.

The report shall clearly summarize the sensitivity for detecting VF, and the sensitivity for detecting VT for those devices designed to treat VT. For those devices designed to treat certain types of ventricular tachycardia (VT) a description of the requirements for indication of VT as a shockable rhythm shall be included. The positive predictive accuracy, the false positive rate and overall specificity of the device shall also be reported. Reporting the specificity of the device for each non-shockable rhythm group (i.e. normal sinus rhythm, supraventricular rhythms such as atrial fibrillation and atrial flutter, ventricular ectopy, idioventricular rhythms and asystole) is recommended but not required.

The sensitivity of the device to recognize VF at maximum peak to peak amplitude of 200 μV or greater shall exceed 90 % in the absence of artifacts (e.g., induced by cardiopulmonary resuscitation). For those devices which detect VT, the sensitivity shall exceed 75 %. The specificity of the detector in correctly differentiating non-shockable rhythms shall exceed 95 % in the absence of artifacts.

- b) If the detector initiates analysis of the rhythm either automatically or following manual initiation by the OPERATOR, this shall be described.
- c) If the DEFIBRILLATOR incorporates a system that detects and analyzes physiological information other than the ECG, in order to increase the sensitivity or specificity of the AED, the technical description shall explain the method of operation of this system and the criteria for recommending shock delivery.

6.8.101 Accompanying documents related to electromagnetic compatibility

In accordance with IEC 60601-1-2, the manufacturer shall include information regarding electromagnetic compatibility of the EQUIPMENT. Specifically, Tables 201, 202 and 203a shall be provided and applicable statements in accordance with 6.8.201.2 shall be included in the instructions for use.

SECTION TWO – ENVIRONMENTAL CONDITIONS

The clauses and subclauses of this section of the General Standard apply except as follows:

10 Environmental conditions

This clause of the General Standard applies except as follows:

***10.2 Operation**

10.2.1 Environment

Amendment:

- a) Ambient temperature between 0 °C and +40 °C.
- b) Relative humidity between 30 % and 95 %, without condensation.

SECTION THREE – PROTECTION AGAINST ELECTRIC SHOCK HAZARDS

The clauses and subclauses of this section of the General Standard apply except as follows:

14 Requirements related to classification

This clause of the General Standard applies except as follows:

14.6 Types b, bf and cf applied parts

Addition

- *aa) Any APPLIED PART consisting of SEPARATE MONITORING ELECTRODES for monitoring the ECG shall be TYPE CF.

***17 Separation**

This clause of the General Standard applies except as follows:

*h) first dash

Additional bullet:

- APPLIED PARTS of other PATIENT CIRCUITS;

Amendment:

Delete sixth dash ("the EQUIPMENT shall not be energized;").

Replace second to last paragraph ("Each test is repeated with V_T reversed.") by the following:

Each test is performed both with the EQUIPMENT energized and not energised in turn and is repeated with V_T reversed in each case.

Additional items:

aa) Arrangements to isolate the DEFIBRILLATOR ELECTRODES from other parts shall be so designed that, during the discharge of the ENERGY STORAGE DEVICE, hazardous electrical energies are excluded from the following:

- 1) the ENCLOSURE;
- 2) all PATIENT CONNECTIONS belonging to other PATIENT CIRCUITS;
- 3) any SIGNAL INPUT PART and/or any SIGNAL OUTPUT PART;
- 4) a metal foil on which the EQUIPMENT is placed and which has an area at least equal to that of the base of the EQUIPMENT (CLASS II EQUIPMENT or EQUIPMENT with an INTERNAL ELECTRICAL POWER SOURCE).

Compliance shall be checked by the following test:

The above requirement is met when, after a discharge of the DEFIBRILLATOR connected as shown in Figure 101, the peak voltage between the points Y1 and Y2 does not exceed 1 V. Transients might be imposed on the measurement during the energy discharge. These shall be excluded from the measurement. This voltage corresponds to a charge of 100 μC from the part under test.

In the case where an active signal output part would effect the measured voltage between Y1 and Y2 the specific signal output port is excluded from the measurement. However the ground reference of such a signal output port shall be measured.

In the case where the connection of the measurement circuit of fig. 101 to an input/output port would create a failure of the device to function properly, the specific input/output port is excluded from measurement. However the ground reference of such an input/output signal shall be measured.

DEFIBRILLATORS requiring an impedance within a certain range to be present at the output of the DISCHARGE CIRCUIT are to be tested connected to a 50 Ω resistive load. In the case of DEFIBRILLATORS requiring the detection of a shockable ECG in order to deliver a shock, an ECG simulator incorporating a 50 Ω resistive load is to be used.

Measurements shall be done at the maximum energy level of the device.

CLASS I EQUIPMENT shall be tested while connected to the protective earth.

CLASS I EQUIPMENT which is capable of operation without a SUPPLY MAINS, e.g. having an internal battery, shall also be tested without the protective earth connection.

Any connection to a FUNCTIONAL EARTH TERMINAL shall be removed.

The test shall be repeated with the earth connection transferred to the other DEFIBRILLATOR ELECTRODE.

- *bb) Any APPLIED PARTS not being DEFIBRILLATOR ELECTRODES shall be DEFIBRILLATION-PROOF APPLIED PARTS unless the manufacturer has taken steps to prevent their use at the same time as performing defibrillation with the same DEFIBRILLATOR.
- *cc) Unintentional charging of the ENERGY STORAGE DEVICE shall not occur when testing the requirements for DEFIBRILLATION-PROOF APPLIED PARTS according to this clause.

19 Continuous LEAKAGE CURRENTS and PATIENT AUXILIARY CURRENTS

This clause of the General Standard applies except as follows:

*19.1 General requirements

Item b), third dash

Addition:

For the measurement of PATIENT LEAKAGE CURRENT and PATIENT AUXILIARY CURRENT the EQUIPMENT shall be operated in turn:

- a) in STAND-BY;
- b) while the ENERGY STORAGE DEVICE is being charged to maximum energy;
- c) while the ENERGY STORAGE DEVICE is maintained at maximum energy until internal energy discharge is automatically performed, or for 1 min;
- d) for 1 min, starting 1 s after the commencement of the output pulse into a 50 Ω load (the period of discharge being excluded).

Item e)

Addition:

For the DEFIBRILLATOR ELECTRODES the requirements of the General Standard are replaced by the following:

The PATIENT LEAKAGE CURRENT shall be measured with the DEFIBRILLATOR ELECTRODES connected to a 50 Ω load, The measurement shall be made from either DEFIBRILLATOR ELECTRODE to earth, the following parts being connected together and to earth:

- a) conductive ACCESSIBLE PARTS;
- b) metal foil on which the EQUIPMENT is positioned and which has an area at least equal to that of the base of the EQUIPMENT;
- c) any SIGNAL INPUT PARTS and SIGNAL OUTPUT PARTS which may be connected to earth in NORMAL USE.

19.2 Single fault conditions

Item b) second dash

Addition:

For the DEFIBRILLATOR ELECTRODES, this requirement of the General Standard is replaced by the following:

- a voltage equal to 110 % of the highest RATED MAINS VOLTAGE applied between earth and, in turn, the external DEFIBRILLATOR ELECTRODES connected together and any internal DEFIBRILLATOR ELECTRODES connected together, metal foil being wrapped around, and in intimate contact with, the electrode handles and connected to earth and to the parts of 19.1 e) of this Particular Standard.

* 19.3 Allowable values

Additional item:

- *aa) For TYPE CF DEFIBRILLATOR APPLIED PARTS, the allowable value of the PATIENT LEAKAGE CURRENT for the SINGLE FAULT CONDITION of MAINS VOLTAGE on the DEFIBRILLATOR ELECTRODES is 0,1 mA.

* 20 Dielectric strength

This clause of the General Standard applies except as follows:

20.2 Requirements for EQUIPMENT with an APPLIED PART

and

20.3 Values of test voltages

Amendment:

For the DEFIBRILLATOR high-voltage circuit (for example DEFIBRILLATOR ELECTRODES, CHARGING CIRCUIT and switching devices) the following requirements and tests shall apply in addition to those of the General Standard for insulation category B-a and shall replace those of the General Standard for insulation categories B-b, B-c, B-d and B-e.

The insulation of the above circuit shall withstand a d.c. test voltage of 1,5 times the highest peak voltage U occurring between the parts concerned during discharging in any mode of normal operation. The insulation resistance of the above insulation shall not be less than 500 M Ω .

Compliance shall be checked by the following combined dielectric strength and insulation resistance test:

The external d.c. test voltage is applied:

Test 1: With the switching devices of the DISCHARGE CIRCUIT activated between each pair of DEFIBRILLATOR ELECTRODES connected together and all of the following parts connected together:

- a) conductive ACCESSIBLE PARTS,*
- b) the PROTECTIVE EARTH TERMINAL in the case of CLASS I EQUIPMENT or metal foil on which the EQUIPMENT rests in the case of CLASS II EQUIPMENT or EQUIPMENT with an INTERNAL ELECTRICAL POWER SOURCE,*
- c) metal foil in intimate contact with non-conductive parts liable to be handled in NORMAL USE, and*
- d) any isolated DISCHARGE CONTROL CIRCUIT and any isolated SIGNAL INPUT or SIGNAL OUTPUT PART.*

If the CHARGING CIRCUIT is floating and is isolated from the DEFIBRILLATOR ELECTRODES during discharging it shall be connected to them during this test.

Any resistors forming the isolating means between the DEFIBRILLATOR and other PATIENT CIRCUITS shall be replaced by a DUMMY COMPONENT.

Any other PATIENT CONNECTIONS, their cables and associated connectors shall be disconnected from the equipment during this test.

Any switching arrangements used to isolate the high-voltage circuit of the DEFIBRILLATOR from the other PATIENT circuits, other than those activated in NORMAL USE by the connection of their respective cables and PATIENT CONNECTIONS, shall be held in the open-circuit position.

Any resistors bridging the insulation under test (e.g. components of a metering circuit) shall be replaced by a DUMMY component during this test provided that their effective value in the test configuration is not less than 5 M Ω . Any components which are known not to withstand the test voltage of 1,5 U , but which have been demonstrated to be safe

by the test at the end of this subclause, shall be accepted as meeting the requirements of this subclause.

NOTE "Pair" here refers to any two DEFIBRILLATOR ELECTRODES used together in NORMAL USE.

Newer circuit topologies for DEFIBRILLATORS may make it difficult to carry out the test outlined above. Components which are not rated at 1,5 U, or which are known to fail at less than 1,5 U, are acceptable if they pass the following test. The highest peak voltage U is determined by circuit analysis, making allowances for circuit component tolerances. The distribution of breakdown voltages for the component under test is obtained from the supplier, or is determined by testing to breakdown a sample of sufficient size, to yield 90 % confidence that the probability of failure of the component at U is less than 0,0001. In addition, manufacturers shall through fault mode and effect analysis (see IEC 60300-3-9) demonstrate that the implemented circuit topology does not create a SAFETY HAZARD in SINGLE FAULT CONDITION and that the OPERATOR is made aware of such a failure.

Test 2: Between the defibrillator electrodes of each pair – external and internal in turn –while:

- a) the ENERGY STORAGE DEVICE is disconnected,*
- b) THE switching devices of the DISCHARGE CIRCUIT are activated,*
- c) any switching arrangements used to isolate the high-voltage circuit of the DEFIBRILLATOR FROM other PATIENT CIRCUITS are held in the open-circuit position, and*
- d) any COMPONENTS which would provide a conductive pathway between the DEFIBRILLATOR ELECTRODES during this test are disconnected.*

Newer circuit topologies for DEFIBRILLATORS may make it difficult to carry out the test outlined above. Components which are not rated at 1,5 U, or which are known to fail at less than 1,5 U, are acceptable if they pass the following test. The highest peak voltage U is determined by circuit analysis, making allowances for circuit component tolerances. The distribution of breakdown voltages for the component under test is obtained from the supplier, or is determined by testing to breakdown a sample of sufficient size, to yield 90 % confidence that the probability of failure of the component at U is less than 0,0001. In addition, manufacturers shall, through fault mode and effect analysis (see IEC 60300-3-9), demonstrate that the implemented circuit topology do not create a SAFETY HAZARD in SINGLE FAULT CONDITION and that the OPERATOR is made aware of such a failure.

Test 3: Across each switching device in the DISCHARGE CIRCUIT and in the CHARGING CIRCUIT.

In the case of switches in the DISCHARGE CIRCUIT intended to operate in series as a single functional group, the following tests shall be performed.

- a) Place the test voltage across each functional group in the polarity consistent with that of the ENERGY STORAGE DEVICE and verify d.c. withstand per the provisions of the section.*
- b) Disconnect the ENERGY STORAGE DEVICE and substitute with a test voltage source set per the CALCULATIONS above, with polarity consistent with the ENERGY STORAGE DEVICE.*

By shorting functional groups, simulate cascade-failures of each series functional switching group in turn. Demonstrate that, under simulated cascade failure conditions, energy discharge to the PATIENT connection does not occur.

Test 4: Between the mains part and the DEFIBRILLATOR electrodes connected together while the switching devices of the discharge circuit are activated.

NOTE It may not be possible to activate the switching means for extended periods of time. In such cases the switching procedure may be simulated for this test.

This test shall not be performed if the mains part and the applied part containing the DEFIBRILLATOR electrodes are effectively separated by a protectively earthed shield or a protectively earthed intermediate circuit.

Where the effectiveness of the separation is in doubt (e.g. the protective shielding is incomplete) the shield shall be disconnected and the dielectric strength test performed.

The test voltage is initially set at U and the current is measured. The voltage is raised to $1,5 U$ in a time of not less than 10 s and then maintained constant for a period of 1 min during which no breakdown or flashover shall occur.

The current shall be proportional to the applied test voltage within $\pm 20\%$. Any transient increase in the current due to non-linearity of the increase of the test voltage shall be ignored. The insulation resistance shall be calculated from the maximum voltage and the steady-state current.

During the tests specified in the General Standard for insulation category B-a, that portion of the test voltage appearing across any switching device in the charging circuit or in the discharge circuit shall be restricted so as not to exceed a peak value equal to the d.c. test voltage specified above.

20.4 Tests

Item a), first dash

Amendment:

Change "warming up to operating temperature" to read "attaining the steady-state temperature reached by the EQUIPMENT operating in STAND-BY".

SECTION FOUR – PROTECTION AGAINST MECHANICAL HAZARDS

The clauses and subclauses of this section of the General Standard apply.

SECTION FIVE – PROTECTION AGAINST HAZARDS FROM UNWANTED OR EXCESSIVE RADIATION

The clauses and subclauses of this section of the Collateral Standard IEC 60601-1-2, 2001 apply except as follows:

***36 Electromagnetic compatibility (EMC)**

Replacement:

36.201 Emissions

These requirements are waived during a DEFIBRILLATOR charge/discharge cycle.

36.201.1 Protection of radio services

a) Requirements

The DEFIBRILLATOR shall comply with the requirements of CISPR 11, group 1, in all configurations and operating modes. DEFIBRILLATORS are classified as Class B EQUIPMENT for determining applicable CISPR 11 requirements. Emission levels measured 10 m from the INSTRUMENT shall not exceed 30 dB μ V from 30 MHz to 230 MHz and shall not exceed 37 dB μ V from 230 MHz to 1 000 MHz.

b) Tests:

Compliance shall be checked in accordance with CISPR test methods.

Replacement:

36.202.2 Electrostatic discharge (ESD)

a) Requirements

For open air discharges up to 4 kV and direct contact discharges up to 2 kV, the OPERATOR shall not notice any change in EQUIPMENT operation. The EQUIPMENT shall operate within normal limits of its specifications. No degradation of system performance or loss of functionality is allowed. However, ECG spikes, pacemaker pulse detection, display glitches, or momentary light-emitting diode (LED) flashes are acceptable during an ESD discharge.

For open air discharges up to 8 kV or direct contact discharges up to 6 kV, the EQUIPMENT may exhibit momentary loss of functionality but shall recover within 2 s without OPERATOR intervention. There shall be no unintended energy delivery, unsafe failure mode, or loss of stored data.

b) Tests

The test methods and INSTRUMENTS specified in IEC 61000-4-2 apply with the following addition:

The EQUIPMENT is exposed, at any point on its surface accessible to the OPERATOR or PATIENT, to open air discharges up to 8 kV or direct contact discharges up to 6 kV, both positive and negative.

36.202.3 Radiated RF electromagnetic fields

a) Requirements

The EQUIPMENT is exposed to a modulated RF field with the following characteristics:

- field strength: 10 V/m;
- carrier frequency range: 80 MHz to 2,5 GHz;
- AM modulation, 80 % index, at 5 Hz.

b) Tests

The test methods and INSTRUMENTS specified in IEC 61000-4-3, apply with the following modifications:

Compliance shall be checked by the following test:

The DEFIBRILLATOR ELECTRODES are terminated in a simulated PATIENT load (1 k Ω resistor in parallel with a 1 μ F capacitor). The INSTRUMENT is tested with all its faces sequentially exposed to the RF field. When exposed to a field strength of 10 V/m, no inadvertent discharge or other unintended change of state shall occur. No inadvertent activation of the RRD (false positive) shall be allowed. When exposed to a field strength of 20 V/m, no inadvertent energy delivery is allowed.

Certain PATIENT cable configurations may cause failure to meet these immunity requirements. In such a case, the manufacturer shall disclose the reduced immunity levels which are met.

36.202.4 Electrical fast transients and bursts

a) Requirements

Mains connectable INSTRUMENTS shall test using level 3 at the mains plug. Only transient loss of functionality is allowed. No inadvertent energy delivery or other unintentional change of state is allowed. The device shall revert to its condition just prior to the burst without OPERATOR intervention.

b) *Tests*

The test methods and INSTRUMENTS specified in IEC 61000-4-4 apply.

36.202.5 Surges

a) *Requirements*

Mains connectable EQUIPMENT shall be tested according to installation Clause 3. Compliance criteria: no inadvertent energy delivery or other unintentional change of state is allowed. The device shall revert to its prior condition without OPERATOR intervention.

b) *Tests*

The test methods and INSTRUMENTS specified in IEC 61000-4-5 apply.

36.202.6 Conducted disturbances, induced by RF fields

a) *Requirements*

No inadvertent discharge or other unintentional change of state shall occur during this period. No loss of functionality is allowed.

b) *Tests*

The test methods and INSTRUMENTS specified in IEC 61000-4-6 apply with the following modifications:

When a DEFIBRILLATOR can be operated from line power as well as a battery, an RF voltage with the following characteristics is injected into the input power cord (not in the signal input):

- *RF voltage amplitude: 3 V r.m.s.;*
- *carrier frequency: 150 kHz to 80 MHz;*
- *AM modulation, 80 % index, at 5Hz.*

36.202.8 Magnetic fields

a) *Requirements*

No inadvertent discharge or other unintentional change of state shall occur during this test. Some display jitter is allowed, however the displayed information shall be readable and stored data shall not be lost or corrupted.

b) *Test*

The test methods and INSTRUMENTS specified in IEC 61000-4-8 are applied as follows:

The EQUIPMENT is exposed on all axes. The ECG leads and electrodes are short-circuited at the instrument.

**SECTION SIX- PROTECTION AGAINST HAZARDS OF IGNITION OF
FLAMMABLE ANAESTHETIC MIXTURES**

The clauses and subclauses of this section of the General Standard apply.

**SECTION SEVEN – PROTECTION AGAINST EXCESSIVE TEMPERATURES
AND OTHER SAFETY HAZARDS**

The clauses and subclauses of this section of the General Standard apply except as follows:

* 42 Excessive temperatures

This clause of the General Standard applies except as follows:

42.3

Item 3) *DUTY CYCLE*

Replacement:

The EQUIPMENT is operated in STAND-BY until temperature equilibrium is attained. For MANUAL DEFIBRILLATORS, the DEFIBRILLATOR is alternately charged and discharged with its maximum energy 15 times at the rate of three per minute into a resistive load of 50 Ω . For AEDs the number and rate of discharges shall be the maximum specified by the manufacturer for normal operation.

44 Overflow, spillage, leakage, humidity, ingress of liquids, cleaning, sterilization, disinfection and compatibility

This clause of the General Standard applies except as follows:

* 44.6 Ingress of liquids

Replacement:

The EQUIPMENT shall be so constructed that, in the event of spillage of liquids (accidental wetting), no SAFETY HAZARD shall result.

Compliance shall be checked by the following test:

One sample of the EQUIPMENT is placed in the least favorable position of NORMAL USE with the DEFIBRILLATOR ELECTRODES in the stored position. The EQUIPMENT is then subjected for 30 s to an artificial rainfall of 3 mm/min falling vertically from a height of 0,5 m above the top of the EQUIPMENT. The EQUIPMENT shall not be energized during the test. PATIENT cables, mains cables etc., shall be placed in the least favorable position during the test.

A test apparatus is shown in Figure 3 of IEC 60529.

An intercepting device may be used to determine the duration of the test.

Immediately after the 30-second exposure, visible moisture on the ENCLOSURE is removed. Immediately after the above test, the DEFIBRILLATOR is alternately charged and discharged with its maximum energy 15 times at the rate of three per minute into a resistive load of 50 Ω . For AEDs, the maximum number of discharges and rate of discharge may be limited to the manufacturer's specifications for normal operation.

It shall be verified that any water which may have entered the EQUIPMENT cannot result in a SAFETY HAZARD. In particular the EQUIPMENT shall be capable of meeting the dielectric strength tests A-a₁, A-a₂. For APPLIED PARTS which are not DEFIBRILLATOR ELECTRODES the EQUIPMENT shall be capable of meeting the dielectric strength tests B-a and B-d specified in 20.1 to 20.3 in the General standard.

After the test the DEFIBRILLATOR is disassembled to inspect for water ingress. The EQUIPMENT shall show no signs of wetting of electrical insulation, which is liable to be adversely affected by such liquid. There shall be no sign of water in the high-voltage circuitry.

The EQUIPMENT shall function normally.

*** 44.7 Cleaning, sterilization and disinfection**

Addition:

Internal DEFIBRILLATOR ELECTRODES including handles, any incorporated controls or indicators, and associated cables shall be sterilizable. See 6.8.2 aa) 6) for requirements for instructions for use.

46 Human errors

This clause of the General Standard applies except as follows:

Replacement:

46 Human errors

***46.101 ELECTRODE energizing controls**

- a) The EQUIPMENT shall be so designed as to prevent the external and internal DEFIBRILLATOR ELECTRODES being energized simultaneously.

Compliance shall be checked by inspection and functional test.

- b) The means for triggering the DEFIBRILLATOR DISCHARGE CIRCUIT shall be so designed as to minimize the possibility of inadvertent operation.

Acceptable arrangements are:

- 1) for anterior-anterior DEFIBRILLATOR ELECTRODES, two momentary switches, one located on each DEFIBRILLATOR ELECTRODE handle;
- 2) for anterior-posterior DEFIBRILLATOR ELECTRODES, a single momentary switch located on the anterior electrode handle;
- 3) for internal DEFIBRILLATOR ELECTRODES, a single momentary switch located on one of the electrode handles or one or two single momentary switches on the panel only;
- 4) for external self-adhesive DEFIBRILLATOR ELECTRODES, one or two single momentary switches located on the panel only.

Foot-operated switches shall not be used to trigger the defibrillation pulse.

Compliance shall be checked by inspection and functional test.

46.102 Display of signals

The DEFIBRILLATOR shall not display signals from more than one input simultaneously unless the origin of the signals is labeled unambiguously.

Compliance shall be checked by inspection.

*** 46.103 Audible warnings prior to energy delivery**

Audible warnings to the OPERATOR shall be provided prior to energy delivery by the DEFIBRILLATOR. As a minimum requirement, voice or audible tones shall be provided at the following times (warnings may be continuous or intermittent):

- a) for AEDs, when the RHYTHM RECOGNITION DETECTOR has reached a determination that a shockable rhythm is detected;

- b) in the case of DEFIBRILLATORS with OPERATOR activated discharge control, when the device is ready to be discharged by the OPERATOR.
- c) in the case of AEDs with automatic discharge control, at least 5 s prior to energy delivery.

SECTION EIGHT – ACCURACY OF OPERATING DATA AND PROTECTION AGAINST HAZARDOUS OUTPUT

The clauses and subclauses of this section of the General Standard apply except as follows:

***50 Accuracy of operating data**

This clause of the General Standard applies except as follows:

***50.1 Marking of controls and INSTRUMENTS**

Replacement:

If the DEFIBRILLATOR is provided with means for the selection, continuously or in steps, of the SELECTED ENERGY then an indication of the SELECTED ENERGY in joules shall be incorporated, expressed as the nominal DELIVERED ENERGY in joules to a resistive load of 50 Ω .

Alternatively, the DEFIBRILLATOR may deliver a single preset energy, or a sequence of energies according to a preset protocol described in the instructions for use. If the DEFIBRILLATOR is designed to supply a single energy, or a programmed sequence of energies, no means for energy selection is required.

Compliance shall be checked by inspection

*** 50.2 Accuracy of controls and INSTRUMENTS**

Replacement:

The rated DELIVERED ENERGY (according to EQUIPMENT SETTINGS) into loads of 25 Ω , 50 Ω , 75 Ω , 100 Ω , 125 Ω , 150 Ω , and 175 Ω shall be specified. The measured DELIVERED ENERGY into these load resistances shall not vary from the DELIVERED ENERGY for that impedance by more than ± 3 J or ± 15 %, whichever is greater, at any energy level.

Compliance shall be checked by measurement of DELIVERED ENERGY in load resistances of 25 Ω , 50 Ω , 75 Ω , 100 Ω , 125 Ω , 150 Ω , and 175 Ω at energy levels as above or by measurement of the internal resistance of the DEFIBRILLATOR output circuit and hence calculation of the DELIVERED ENERGY.

51 Protection against hazardous output

This clause of the General Standard applies except as follows:

*** 51.1 Intentional exceeding of safety limits**

Addition:

Output control range

- a) The SELECTED ENERGY shall not exceed 360 J.
- b) For internal DEFIBRILLATOR ELECTRODES the SELECTED ENERGY shall not exceed 50 J.

Compliance shall be checked by inspection and functional test.

Addition:

***51.101** The output voltage of the DEFIBRILLATOR across a 175 Ω load resistance shall not exceed 5 kV.

Compliance shall be checked by measurement.

*** 51.102** The *EQUIPMENT* shall be so designed that in the event of a power failure (either of the supply mains or of the internal electrical power source) or when the *EQUIPMENT* is switched off, no unintentional energy shall be available at the DEFIBRILLATOR electrodes.

Compliance shall be checked by functional test.

*** 51.103** A DEFIBRILLATOR shall be provided with an internal discharge circuit whereby STORED ENERGY that for some reason is not to be delivered through the DEFIBRILLATOR electrodes can be dissipated without energizing the DEFIBRILLATOR electrodes.

This INTERNAL DISCHARGE CIRCUIT may be combined with that required by 51.102.

Compliance shall be checked by functional test.

SECTION NINE – ABNORMAL OPERATION AND FAULT CONDITIONS; ENVIRONMENTAL TESTS

The clauses and subclauses of this section of the General Standard apply except as follows:

52 Abnormal operation and fault conditions

Addition:

***52.4.101** Inadvertent charging or discharging of the energy storage device.

SECTION TEN – CONSTRUCTIONAL REQUIREMENTS

The clauses and subclauses of this section of the General Standard apply except as follows:

*** 56 Components and general assembly**

This clause of the General Standard applies except as follows:

Addition:

*** 56.101 DEFIBRILLATOR electrodes and their cables**

a) Any DEFIBRILLATOR ELECTRODE handles shall have no conductive ACCESSIBLE PARTS.

This requirement does not apply to small metal parts such as screws in or through insulating material which cannot become live under single fault conditions.

Compliance shall be checked by inspection and the dielectric strength test (see Test 1, 20.2).

- *b) DEFIBRILLATOR ELECTRODE cables and their anchorages shall be capable of satisfactorily passing the following tests. Additionally the anchorages for reusable DEFIBRILLATOR ELECTRODES shall comply with the requirements for POWER SUPPLY CORDS as described in dashes 1 – 4 of item a) of 57.4 of the General Standard. For single use cables or cable/electrode assemblies the number of cycles of flexing in Test 2 shall be divided by 100. Each cable to EQUIPMENT/DEFIBRILLATOR ELECTRODE and each cable to EQUIPMENT/DEFIBRILLATOR ELECTRODE connector, where relevant, in turn shall be subjected to the tests as for DEFIBRILLATOR ELECTRODES, unless two or more connectors have identical construction, in which case only one of these shall be tested. Where a connector is fitted with two or more cables these shall be tested together, the total tension on the connector being the sum of the tensions appropriate to each cable individually. (See Annex AA and Figure 108 for guidance on identification of anchorages that require testing).

Compliance shall be checked by inspection and by the following tests:

Test 1: For rewirable cable, the conductors are introduced in the terminals in the DEFIBRILLATOR ELECTRODES, any terminal screws being tightened just sufficiently to prevent easy displacement of the conductors. The cord anchorage is then tightened in the normal way. For all cables, to measure the longitudinal displacement a mark is made on the cable at a distance of approximately 2 cm from the cord anchorage.

Immediately afterwards the cable shall be subjected to a pull of 30 N, or the maximum force that can be applied to the anchorage before the connector becomes disconnected, or the electrode is pulled off the PATIENT, where applicable, for 1 min, whichever is the least. At the end of this period the cable shall not have been displaced longitudinally by more than 2 mm. For rewirable cables the conductors shall not have moved by more than 1 mm in the terminals nor shall there be appreciable strain on the conductors while the pull is still being applied. For non-rewirable cables not more than 10 % of the total number of conductor strands in each wire of the cable may have been broken.

Test 2: One DEFIBRILLATOR ELECTRODE is fixed in an apparatus similar to that shown in Figure 102, so that when the oscillating member of the apparatus is at the middle of its travel, the axis of the cable, where it leaves the electrode or electrode handle, is vertical and passes through the axis of oscillation. Tension is applied to the cable as follows:

- i) for extensible cables a tension equal to that necessary to extend the cable to three times its natural (unextended) length, or to the weight of one DEFIBRILLATOR ELECTRODE, whichever is the greater, is applied and the cable is clamped at a distance of 300 mm from the axis of oscillation;*
- ii) for non-extensible cables, the cable is passed through an aperture 300 mm from the axis of oscillation and a weight equal to the weight of one DEFIBRILLATOR ELECTRODE, or 5 N, whichever is the greater, is fixed to the cable below this aperture.*

The oscillating member is rotated through an angle of

- 180 ° (90 ° on each side of the vertical) for internal electrodes;*
- 90 ° (45 ° on each side of the vertical) for external electrodes.*

The number of cycles shall be 10 000 at the rate of 30 cycles per minute. After 5 000 cycles the DEFIBRILLATOR ELECTRODE is turned through 90° about the centre line of the cable entry point and the remaining 5 000 cycles are completed in this plane.

After the test, the cable shall not have worked loose and neither the cord anchorage nor the cable shall show any damage, except that not more than 10 % of the total number of conductor strands in each wire of the cable may have been broken.

- c) *Minimum DEFIBRILLATOR ELECTRODE area*

The minimum area of each of the DEFIBRILLATOR ELECTRODES shall be:

- 50 cm² for adult external use;*

- 32 cm² for adult internal use;
- 15 cm² for pediatric external use;
- 9 cm² for pediatric internal use.

57 MAINS PARTS, components and layout

This clause of the General Standard applies except as follows:

57.10 CREEPAGE DISTANCES and AIR CLEARANCES

Additional items:

- *aa) Between the LIVE parts of a DEFIBRILLATOR ELECTRODE and parts of any associated handle and any switches or controls likely to be touched in NORMAL USE there shall be a CREEPAGE DISTANCE of at least 50 mm and an AIR CLEARANCE of at least 25 mm.
- *bb) Except for components where the adequacy of ratings can be demonstrated (e.g. by component manufacturers' ratings or by the dielectric strength tests of Clause 20) the CREEPAGE DISTANCES and AIR CLEARANCES of insulation between the high-voltage circuit and other parts, and between different parts of the high-voltage circuit, shall be at least 3 mm/kV.

This requirement shall also apply to the isolating means between the high-voltage circuit of the DEFIBRILLATOR and other PATIENT CIRCUITS.

Compliance shall be checked by measurement.

- *cc) Non-reusable DEFIBRILLATOR ELECTRODES are not required to comply with the creepage and clearance requirements of bb) above and are not required to comply with the dielectric strength requirements of 20.
- *dd) The cable connecting the DEFIBRILLATOR to the DEFIBRILLATOR ELECTRODES shall have double insulation (two separately moulded insulation layers). For a non-reusable cable included as part of non-reusable DEFIBRILLATOR ELECTRODES, where the non-reusable cable has a length of less than 2 m, there is no requirement of double insulation. The insulation resistance of the cable shall not be less than 500 MΩ. The dielectric strength of the cable shall be tested using a voltage of 1,5 times the highest voltage occurring between the DEFIBRILLATOR ELECTRODES in any normal mode of operation, as described below:

A length of 100 mm of the outside of the cable is wrapped with conductive foil. The test voltage is applied between the high voltage conductor and the outside conductive wrapping. The voltage is raised to 1,5 U in a time of not less than 10 s and then maintained constant for a period of 1 min during which no breakdown or flashover shall occur. The leakage current between the high voltage conductor and the wrapping shall demonstrate an insulation resistance of more than 500 MΩ.

SECTION 101 – ADDITIONAL REQUIREMENTS RELATING TO SAFETY

* 101 Charging time

* 101.1 Requirements for frequent use, manual defibrillators

- a) The time for charging a completely discharged ENERGY STORAGE DEVICE to maximum energy shall not exceed 15 s under the following conditions:
 - when the DEFIBRILLATOR is operated on 90 % of the rated mains voltage;
 - with batteries depleted by the delivery of 15 discharges at maximum energy.

- b) The time from initially switching power on, or from within any OPERATOR programming mode, to charge ready at maximum energy shall not exceed 25 s. This requirement shall apply to charging a completely discharged ENERGY STORAGE DEVICE to maximum energy under the following conditions:
- when the DEFIBRILLATOR is operated on 90 % of the RATED MAINS VOLTAGE,
 - with batteries depleted by the delivery of 15 discharges at maximum energy.

Compliance with 101.1 a) and b) shall be checked by measurement. In the case of INTERNALLY POWERED EQUIPMENT, the test shall start with a new and fully charged battery. In the case of such EQUIPMENT also capable of charging the ENERGY STORAGE DEVICE when connected to the SUPPLY MAINS or to a separate battery charger, compliance is checked when the EQUIPMENT is connected to the SUPPLY MAINS or to the battery charger. In cases with a discharged or missing battery, verify performance is consistent with the markings provided as required by 6.1 bb).

In case of a DEFIBRILLATOR with non-rechargeable batteries, the test shall start with a battery depleted by the delivery of the number of charge/discharge cycles specified by the manufacturer, or when the EQUIPMENT indicates that the battery needs replacement, whichever comes first.

***101.2 Requirements for infrequent use, manual defibrillators**

- a) The following charge time requirements apply.
- When the DEFIBRILLATOR is operated on 90 % of the rated mains voltage, the time for charging a completely discharged energy storage device to maximum energy shall not exceed 20 s.
 - With batteries depleted by the delivery of 6 discharges at maximum energy, the time for charging a completely discharged ENERGY STORAGE DEVICE to maximum energy shall not exceed 20 s.
 - With batteries depleted by the delivery of 15 discharges at maximum energy, the time for charging a completely discharged ENERGY STORAGE DEVICE to maximum energy shall not exceed 25 s.
- b) For the time from initially switching power on, or from within any OPERATOR programming mode, to charge ready at maximum energy the following applies.
- When the DEFIBRILLATOR is operated on 90 % of the RATED MAINS VOLTAGE, the time from switching power on, or from within any OPERATOR programming mode, to charge ready at maximum energy shall not exceed 30 s.
 - With batteries depleted by the delivery of 6 discharges at maximum energy, the time from switching power on, or from within any OPERATOR programming mode, to charge ready at maximum energy shall not exceed 30 s.
 - With batteries depleted by the delivery of 15 discharges at maximum energy, the time from switching power on, or from within any OPERATOR programming mode, to charge ready at maximum energy shall not exceed 35 s

Compliance with 101.2 a) and b) shall be checked by measurement. In the case of INTERNALLY POWERED EQUIPMENT, the test shall start with a new and fully charged battery. In the case of such EQUIPMENT also capable of charging the ENERGY STORAGE DEVICE when connected to the SUPPLY MAINS or to a separate battery charger, compliance is also checked when the EQUIPMENT is connected to the SUPPLY MAINS or to the battery charger. In cases with a discharged or missing battery, verify performance is consistent with the markings provided as required by 6.1 bb).

In case of a DEFIBRILLATOR with non-rechargeable batteries, the test shall start with a battery depleted by the delivery of the number of charge/discharge cycles specified by the manufacturer, or when the EQUIPMENT indicates that the battery needs replacement, whichever comes first.

***101.3 Requirements for frequent use, automated external defibrillators**

- a) The maximum time from activation of the RHYTHM RECOGNITION DETECTOR to the DEFIBRILLATOR being ready for discharge at maximum energy, shall not exceed 30 s under the following conditions :
- when the AED is operated on 90 % of the RATED MAINS VOLTAGE;
 - with batteries depleted by the delivery of 15 discharges at maximum energy.
- *b) The time from initially switching power on, or from within any OPERATOR programming mode, to the DEFIBRILLATOR being ready at maximum energy shall not exceed 40 s. This requirement shall apply to charging a completely discharged ENERGY STORAGE DEVICE to maximum energy under the following conditions:
- when the AED is operated on 90 % of the RATED MAINS VOLTAGE;
 - with batteries depleted by the delivery of 15 discharges at maximum energy.

***101.4 Requirements for infrequent use, automated external defibrillators**

- a) The following charge time requirements for INFREQUENT USE AUTOMATED EXTERNAL DEFIBRILLATORS apply.
- The maximum time from activation of the RHYTHM RECOGNITION DETECTOR to ready for discharge at maximum energy, shall not exceed 35 s when the AED is operated on 90 % of the RATED MAINS VOLTAGE
 - The maximum time from activation of the RHYTHM RECOGNITION DETECTOR to ready for discharge at maximum energy, shall not exceed 35 s with batteries depleted by the delivery of 6 discharges at maximum energy
 - The maximum time from activation of the RHYTHM RECOGNITION DETECTOR to ready for discharge at maximum energy, shall not exceed 40 s with batteries depleted by the delivery of 15 discharges at maximum energy
- b) For the time from initially switching power on, or from within any OPERATOR programming mode, to charge ready at maximum energy the following applies.
- When the AED is operated on 90 % of the RATED MAINS VOLTAGE, the time from switching power on, or from within any OPERATOR programming mode, to charge ready at maximum energy shall not exceed 45 s.
 - With batteries depleted by the delivery of 6 discharges at maximum energy, the time from switching power on, or from within any OPERATOR programming mode, to charge ready at maximum energy shall not exceed 45 s.
 - With batteries depleted by the delivery of 15 discharges at maximum energy, the time from switching power on, or from within any OPERATOR programming mode, to charge ready at maximum energy shall not exceed 50 s.

Compliance with 101.3 a) and b) and 101.4 a) and b) shall be checked by the following test:

A shockable simulated PATIENT rhythm signal as defined by the manufacturer, is applied to the SEPARATE MONITORING ELECTRODES or the DEFIBRILLATOR ELECTRODES. The visual or audible instructions given by the DEFIBRILLATOR are followed. The charge time is measured from RRD activation (for 101.3 a) and 101.4 a)) or initial power on (for 101.3 b) and 101.4 b)) to ready for discharge.

In the case of INTERNALLY POWERED EQUIPMENT, the test shall start with a new and fully charged battery. In the case of such EQUIPMENT also capable of charging the ENERGY STORAGE DEVICE when connected to the SUPPLY MAINS or to a separate battery charger, compliance is checked when the EQUIPMENT is connected to the SUPPLY MAINS or to the battery charger. In cases with a discharged or missing battery, verify performance is consistent with the markings provided as required by 6.1 bb).

In case of a DEFIBRILLATOR with non-rechargeable batteries, the test shall start with a battery depleted by the delivery of the number of charge/discharge cycles specified by the

manufacturer, or when the EQUIPMENT indicates that the battery needs replacement, whichever comes first.

For EQUIPMENT with a pre-programmed energy setting sequence, not changeable by the OPERATOR or USER, the requirement for depletion of batteries with the delivery of maximum energy discharges is relaxed to the number of discharges at the pre-programmed energy setting sequence. In case of pre-programmed energy setting sequence being changeable by the OPERATOR or USER, the requirement for depletion of batteries with the delivery of maximum energy discharges is relaxed to the number of discharges at the worst case energy setting sequence selectable.

102 Internal electrical power source

102.1 General

The requirements of this clause apply whether or not the EQUIPMENT can also be operated from a supply mains.

***102.2 Requirements for MANUAL DEFIBRILLATORS**

The capacity of a new and fully charged battery shall be such that at 0 °C the EQUIPMENT can provide at least 20 defibrillation discharges having each the maximum DELIVERED ENERGY of the EQUIPMENT, performed in cycles, each of which comprising three discharges in 1 min and 1 min rest. For INFREQUENT USE MANUAL DEFIBRILLATORS, each cycle shall consist of three discharges in 90 s with 1 min rest.

Where EQUIPMENT contains the possibility to insert more than one battery which can be selected randomly by the OPERATOR, the requirement of 20 discharges is the total amount of discharges available when the DEFIBRILLATOR is equipped with the maximum amount of batteries.

If the standby battery is not actually mounted in the DEFIBRILLATOR, the standby battery shall not be included in the test.

Compliance shall be checked by a functional test at 0 °C ± 2 °C, the EQUIPMENT having first been prepared as follows:

- a) *The battery shall be fully charged in accordance with the manufacturer's instructions (or until the EQUIPMENT indicates that the battery is fully charged) at an ambient temperature of 20 °C ± 2 °C, or according to environmental operating conditions as specified by the manufacturer according to 10.2, whichever constitutes the most severe conditions.*
- b) *The EQUIPMENT including the battery is cooled to 0 °C ± 2 °C until it reaches thermal equilibrium.*

***102.3 Requirements for automated external defibrillators**

102.3.1 For a FREQUENT USE AED, the capacity of a new and fully charged battery shall be such that at 0 °C the EQUIPMENT can provide at least 20 defibrillation discharges at the maximum DELIVERED ENERGY of the AED performed in cycles, each comprising three discharges in 105 s and 1 min rest.

Where a FREQUENT USE AED contains the possibility to insert more than one battery at the same time which can be selected randomly by the OPERATOR, the requirement of 20 discharges is the total amount of discharges available when the DEFIBRILLATOR is equipped with the maximum amount of batteries.

If the standby battery is not actually mounted in the DEFIBRILLATOR the standby battery shall not be included in the test.

For an AED with a pre-programmed energy setting sequence, not changeable by the OPERATOR or USER, the AED shall be able to deliver 20 defibrillation discharges at the pre-programmed setting. In case of pre-programmed energy setting sequence being changeable by the OPERATOR or USER the AED shall be able to deliver 20 defibrillation discharges at the maximum energy setting sequence selectable.

102.3.2 For an INFREQUENT USE AED, a new and fully charged battery shall be capable of providing at least 20 maximum energy discharges at the maximum DELIVERED ENERGY of the EQUIPMENT performed in cycles, each comprising three discharges in 135 s and 1 min rest.

For an INFREQUENT USE AED with a pre-programmed energy setting sequence, not changeable by the OPERATOR or USER, the AED shall be able to deliver 20 defibrillation discharges at the pre-programmed setting. In case of pre-programmed energy setting sequence being changeable by the OPERATOR or USER the AED shall be able to deliver 20 defibrillation discharges at the maximum energy setting sequence selectable.

Compliance with 102.3.1 and 102.3.2 shall be checked by a functional test at $0\text{ }^{\circ}\text{C} \pm 2\text{ }^{\circ}\text{C}$, the EQUIPMENT having first been prepared as follows:

- a) *The battery shall be fully charged in accordance with manufacturer's instructions (or until the EQUIPMENT indicates that the battery is fully charged) at an ambient temperature of $0\text{ }^{\circ}\text{C} \pm 2\text{ }^{\circ}\text{C}$, $20\text{ }^{\circ}\text{C} \pm 2\text{ }^{\circ}\text{C}$ and $40\text{ }^{\circ}\text{C} \pm 2\text{ }^{\circ}\text{C}$, or according to environmental operating conditions as specified by the manufacturer according to 10.2, whichever are the most severe conditions.*
- b) *The EQUIPMENT including the battery is cooled to $0\text{ }^{\circ}\text{C} \pm 2\text{ }^{\circ}\text{C}$ until it reaches thermal equilibrium.*

A shockable cardiac rhythm signal is applied to the SEPARATE MONITORING ELECTRODES or the DEFIBRILLATOR ELECTRODES. The visual or audible instructions given by the DEFIBRILLATOR are followed ensuring that DEFIBRILLATOR discharges is performed in cycles as specified above.

Where EQUIPMENT contains the possibility to insert more than one battery at the same time which can be selected randomly by the OPERATOR, the requirement of 20 discharges is the total amount of discharges available when the DEFIBRILLATOR is equipped with the maximum amount of batteries.

If the standby battery is not actually mounted in the DEFIBRILLATOR the standby battery shall not be included in the test.

***102.4** Means shall be provided to indicate clearly when non-rechargeable batteries require replacement or rechargeable batteries require recharging. These means shall not make the EQUIPMENT inoperative, and the EQUIPMENT shall be capable of delivering three maximum energy discharges once the indication is given.

For EQUIPMENT with a pre-programmed energy setting sequence, not changeable by the OPERATOR or USER, the AED shall be able to deliver 3 defibrillation discharges at the pre-programmed settings once the indication is given. In case of pre-programmed energy setting sequence being changeable by the OPERATOR or USER the AED shall be able to deliver 3 defibrillation discharges at the maximum energy setting sequence selectable.

Compliance shall be checked by inspection and functional test at $20\text{ }^{\circ}\text{C} \pm 2\text{ }^{\circ}\text{C}$.

102.5 Means shall be provided to indicate clearly when any rechargeable battery is being charged.

Compliance shall be checked by inspection and functional test.

***102.6** Any rechargeable new battery shall enable the EQUIPMENT to pass the following test:

a) *Test requirements for MANUAL DEFIBRILLATOR*

After fully charging the battery, the EQUIPMENT is stored while switched off for 168 h (7 days) at a temperature of 20 °C ± 5 °C and at a relative humidity of 65 % ± 10 %. The EQUIPMENT is then charged and discharged with the maximum DELIVERED ENERGY of the EQUIPMENT, 14 times into a 50 Ω load at the rate of one charge-discharge per minute. The charging time for the 15th charge shall not exceed 15 s (25 s for INFREQUENT USE MANUAL DEFIBRILLATOR).

If the DEFIBRILLATOR contains the possibility to perform a wake-up self-test that is automatically started with pre-selectable intervals when the DEFIBRILLATOR is powered off, the test shall be performed with the wake-up self-test enabled with the shortest possible interval.

b) *Test requirements for automated external defibrillators*

After fully charging the battery, the EQUIPMENT is stored while switched off for 168 h (7 days) at a temperature of 20 °C ± 5 °C and at a relative humidity of 65 % ± 10 %. The EQUIPMENT is then charged and discharged, with the maximum DELIVERED ENERGY of the EQUIPMENT, 14 times into a 50 Ω load at the rate of one charge-discharge per minute. The time measured from application of the shockable cardiac rhythm to the DEFIBRILLATOR is ready for discharge number 15 shall not exceed

- 30 s for FREQUENT USE AEDS;*
- 40 s for INFREQUENT USE AEDS*

For EQUIPMENT with a pre-programmed energy setting sequence, not changeable by the OPERATOR or USER, the requirement for depletion of batteries with the delivery of maximum energy discharges is relaxed to the number of discharges at the pre-programmed energy setting sequence. In a case of the pre-programmed energy setting sequence being changeable by the OPERATOR or USER, the requirement for depletion of batteries with the delivery of maximum energy discharges is relaxed to the number of discharges at the maximum energy setting sequence selectable.

If the DEFIBRILLATOR contains the possibility to perform a wake-up self-test that is automatically started with pre-selectable intervals when the DEFIBRILLATOR is powered off, the test shall be performed with the wake-up self-test enabled with the shortest possible interval.

***103 Endurance**

The EQUIPMENT shall be capable of meeting the following endurance test which shall be carried out after the test for excessive temperatures as specified in Clause 42 of this Standard:

- a) *A FREQUENT USE DEFIBRILLATOR shall be charged and discharged 2 500 times into a 50 Ω load at maximum energy or according to a programmed energy protocol. DEFIBRILLATORS intended for INFREQUENT USE shall be charged and discharged 100 times into a 50 Ω load at maximum energy or according to a programmed energy protocol. During this test forced cooling of the EQUIPMENT and the load is permitted. The accelerated test procedure shall not be allowed to produce temperatures in excess of those obtained in the test of*

Clause 42. INTERNALLY POWERED EQUIPMENT may be supplied from an external power source during this test.

- b) *The DEFIBRILLATOR is charged and discharged ten times at maximum energy or according to an internal protocol, with the DEFIBRILLATOR ELECTRODES short-circuited. The intervals between consecutive discharges shall not exceed 3 min.*

Where short-circuited discharge is not possible, this test does not apply.

- c) *The DEFIBRILLATOR is then charged and discharged five times at maximum energy with the DEFIBRILLATOR ELECTRODES open-circuited, but with one electrode and any conductive ENCLOSURE connected to earth. The test is then repeated with the other electrode and this ENCLOSURE connected to earth. In the case of a non-conductive ENCLOSURE each electrode in turn is connected to earthed metal on which the EQUIPMENT is positioned as in NORMAL USE. The earthed metal shall have an area at least equal to that of the base of the EQUIPMENT.*

The intervals between consecutive discharges shall not exceed 3 min.

Where open-circuited discharge is not possible, this test does not apply.

- d) *For FREQUENT USE DEFIBRILLATORS, each INTERNAL DISCHARGE CIRCUIT is tested 500 times at the maximum STORED ENERGY. The INTERNAL DISCHARGE CIRCUIT used in INFREQUENT USE DEFIBRILLATORS shall be tested 20 times at the maximum STORED ENERGY. During this test forced cooling of the EQUIPMENT and the load is permitted. The accelerated test procedure shall not be allowed to produce temperatures in excess of those obtained in the test of Clause 42. INTERNALLY POWERED EQUIPMENT may be supplied from an external power source during this test.*

After completion of these tests, the EQUIPMENT shall comply with all other requirements of this Standard.

***104 SYNCHRONIZER**

Where a SYNCHRONIZER is provided, the following requirements shall be met:

- a) There shall be a clear indication by a visible and optionally audible signal when the DEFIBRILLATOR is in the synchronized mode.
- b) A defibrillation pulse shall occur only if a synchronization pulse occurs while the discharge control(s) is/are operated.
- c) The maximum time delay from the peak of the QRS or the onset of an external triggering pulse to the peak of the DEFIBRILLATOR output waveform shall be:
- 1) 60 ms where the ECG is derived via an APPLIED PART or a SIGNAL INPUT PART of the DEFIBRILLATOR, or
 - 2) 25 ms where the synchronizing triggering signal (not being an ECG) is derived via a SIGNAL INPUT PART.
- d) The DEFIBRILLATOR shall not default to synchronization mode on power up or on selection of defibrillation mode from any other mode.

***105 Recovery of the MONITOR/ECG INPUT after defibrillation**

105.1 ECG signal derived via DEFIBRILLATOR ELECTRODES

When the DEFIBRILLATOR is tested as described below, after a maximum period of 10 s following the DEFIBRILLATOR pulse the test signal shall be visible on the MONITOR display (if applicable) and the peak-to-valley amplitude of the displayed signal shall not deviate from the original amplitude by more than 50 %.

In addition to the above requirement, the RHYTHM RECOGNITION DETECTOR, if present, shall be able to detect a shockable rhythm 20 s after the defibrillation pulse. In this case, the signal

applied to the DEFIBRILLATOR ELECTRODES shall be a signal recognizable by the DEFIBRILLATOR as shockable.

Compliance shall be checked by a test using the following apparatus, as shown in Figure 103. Self-adhesive electrodes are attached to the metal plates. Paddle surfaces, with conductive gel as supplied by the manufacturer if relevant, are pressed onto the metal plates with an appropriate force.

Any USER selectable sensitivity control is set so that the MONITOR sensitivity is adjusted to 10 mm/mV. Any control affecting the MONITOR frequency response is set to the widest frequency response.

With S₁ closed, the signal generator output is adjusted to give a displayed signal of 10 mm peak-to-valley on the MONITOR display (if applicable). For a DEFIBRILLATOR with a RHYTHM RECOGNITION DETECTOR, the amplitude of the applied shockable rhythm signal shall be adjusted to enable the DEFIBRILLATOR to detect a shockable rhythm.

With S₁ opened, a maximum energy pulse is delivered into the apparatus. S₁ is immediately closed and the MONITOR display is observed. The period of 10 s specified above is measured from this closure of S₁. In addition the ECG RHYTHM RECOGNITION DETECTOR, if relevant, shall have detected a shockable rhythm within 20 s after closure of S₁.

105.2 ECG signal derived via any SEPARATE MONITORING ELECTRODES

The test of 105.1 is performed with the SEPARATE MONITORING ELECTRODES attached to the metal plate using electrodes specified by the manufacturers. The same compliance criteria apply.

105.3 ECG signal derived via non-reusable DEFIBRILLATOR ELECTRODES

When the DEFIBRILLATOR is tested as described below, after a maximum period of 10 s following the defibrillation pulses the ECG shall be visible on the MONITOR display and the peak-to-peak amplitude of the displayed signal shall not deviate from the original amplitude by more than 50 %. For a DEFIBRILLATOR not incorporating a MONITOR, but where the ECG input is used for the ECG RHYTHM RECOGNITION DETECTOR, the ECG shall be correctly interpreted by the ECG RHYTHM RECOGNITION DETECTOR 20 s following the defibrillation pulse.

Compliance shall be checked by the test described below:

A pair of non-reusable DEFIBRILLATOR ELECTRODES of the type(s) recommended by the manufacturer are connected back-to-back (conductive surface against conductive surface). The ELECTRODES are connected to the DEFIBRILLATOR in series with an ENERGY METER/DEFIBRILLATOR TESTER incorporating an ECG simulator. The ECG simulator is set to Ventricular Fibrillation. 10 energy pulses are delivered at the highest energy output of the device, or according to a fixed protocol if such is incorporated in the device. The energy pulses are delivered at the highest rate obtainable with the device.

*** 106 Disturbance to the MONITOR from charging or internal discharging**

NOTE This clause does not apply to DEFIBRILLATORS which do not incorporate a MONITOR.

During charging or internal discharging of the ENERGY STORAGE DEVICE, with the MONITOR display sensitivity set to 10 mm/mV ± 20 %:

- a) any interference visible on the MONITOR display shall not exceed 0,2 mV peak-to-valley, and
- b) the displayed amplitude of a 10 Hz sine wave input of 1 mV peak-to-valley shall not change by more than 20 %.

Any disturbances having a total duration of less than 1 s shall be ignored. A baseline shift shall be ignored provided that the entire signal remains visible on the display.

The above requirement shall be met with the MONITOR input derived as shown in Figure 105:

- a) from any SEPARATE MONITORING ELECTRODES;
- b) from the DEFIBRILLATOR ELECTRODES, any SEPARATE MONITORING ELECTRODES being disconnected;
- c) from the DEFIBRILLATOR ELECTRODES, the SEPARATE MONITORING ELECTRODES being connected to the EQUIPMENT, if applicable.

Compliance shall be checked by measurement.

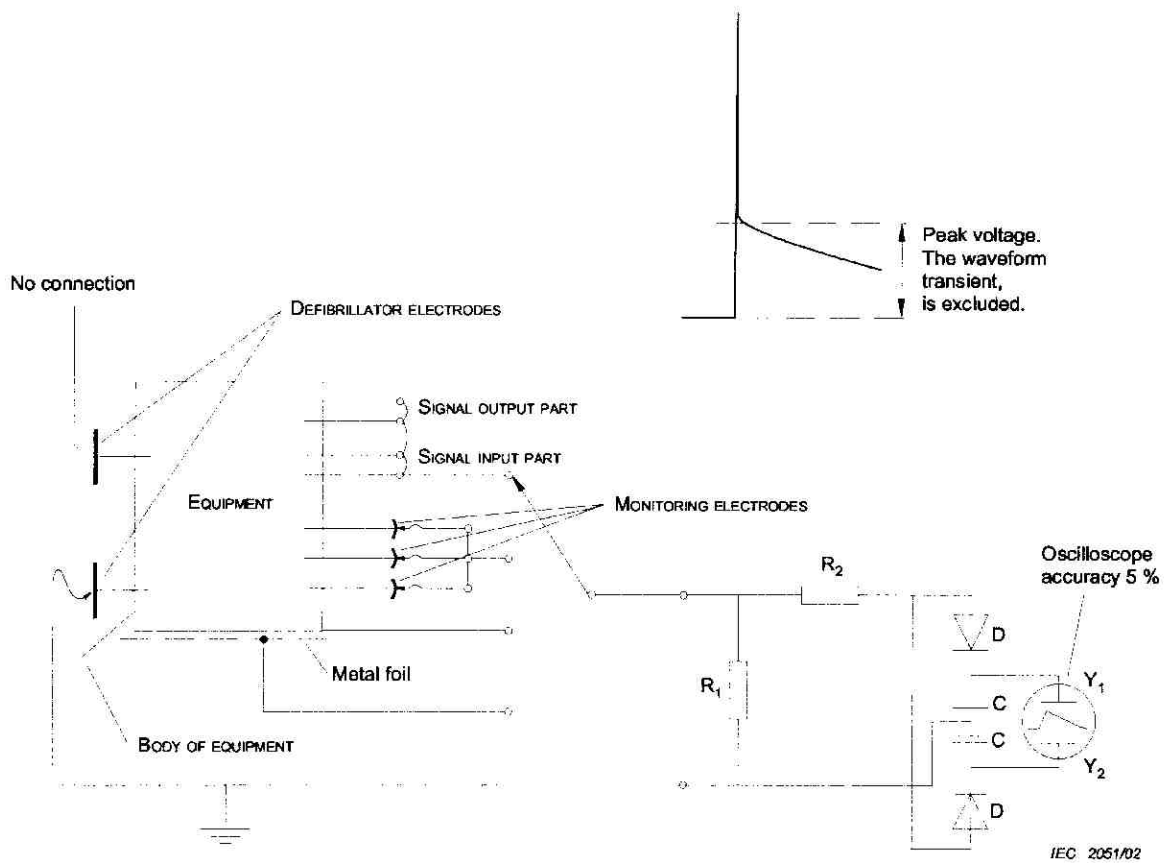

- R₁ = 1 kΩ ± 2% (≥ 2 kV)
- R₂ = 100 kΩ ± 2% (≥ 2 kV)
- C = 1 μF ± 5%
- D : Small signal silicon diodes

Figure 101 – Dynamic test for limitation of energy from different parts of the EQUIPMENT (see item aa) of Clause 17)

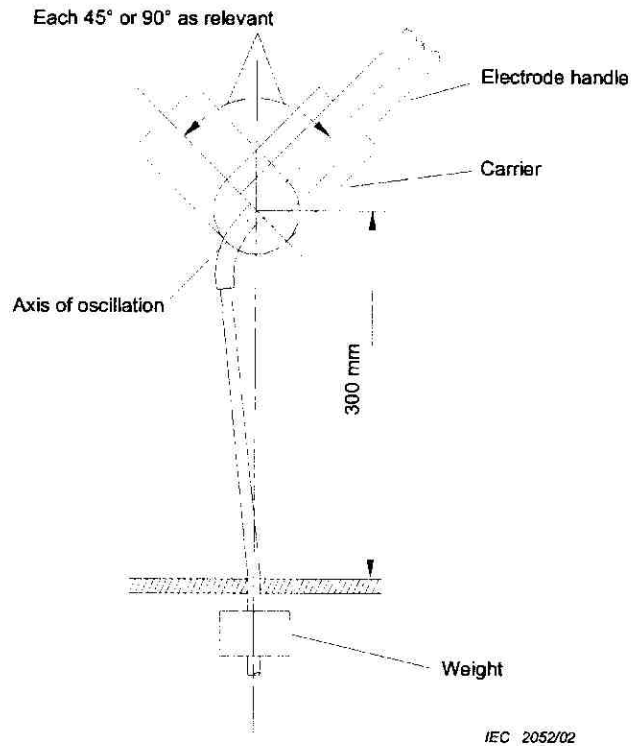

Figure 102 – Test apparatus for flexible cords and their anchorages (see Test 2 of item b) of 56.101)

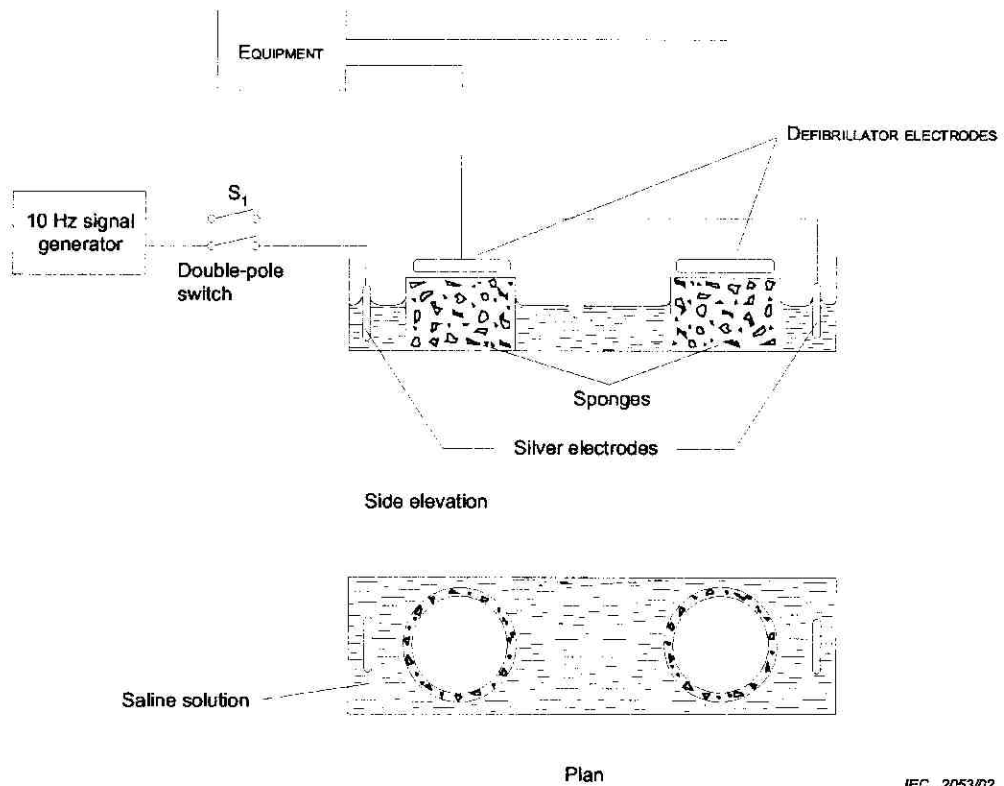
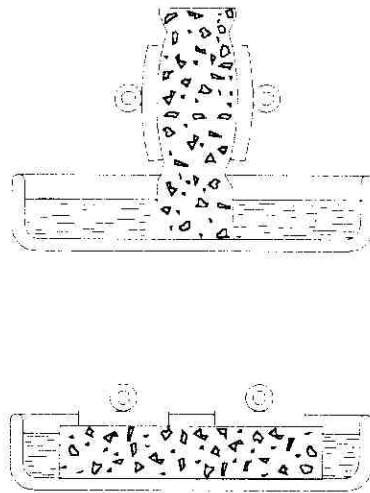
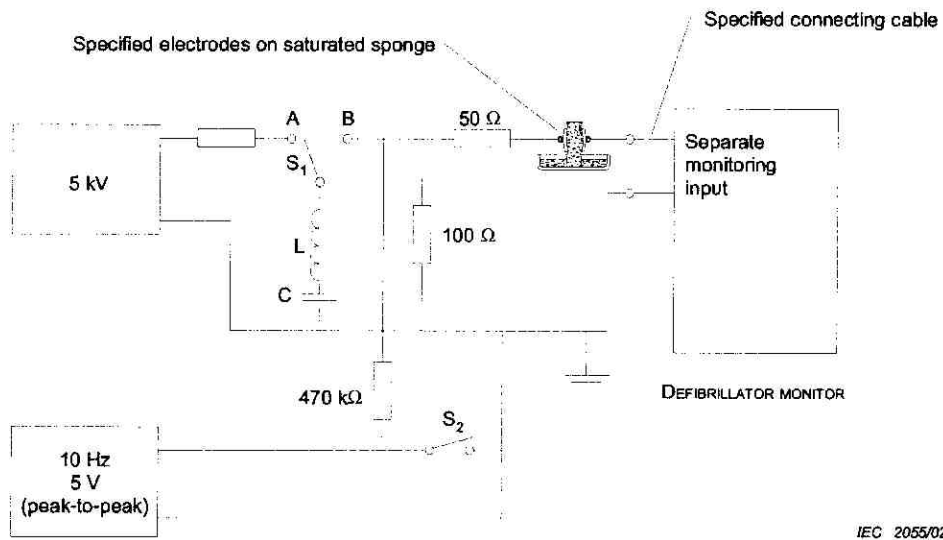

Figure 103 – Arrangement for test of recovery after defibrillation (see 105.1)



IEC 2054/02

Figure 104 – Arrangement of monitoring electrodes on sponge (see 105.2)



IEC 2055/02

$L = 500 \mu\text{H}$
 $R_L \leq 10 \Omega$
 $C = 32 \mu\text{F}$

Figure 105 – Arrangement for recovery test after defibrillation (see 105.2)

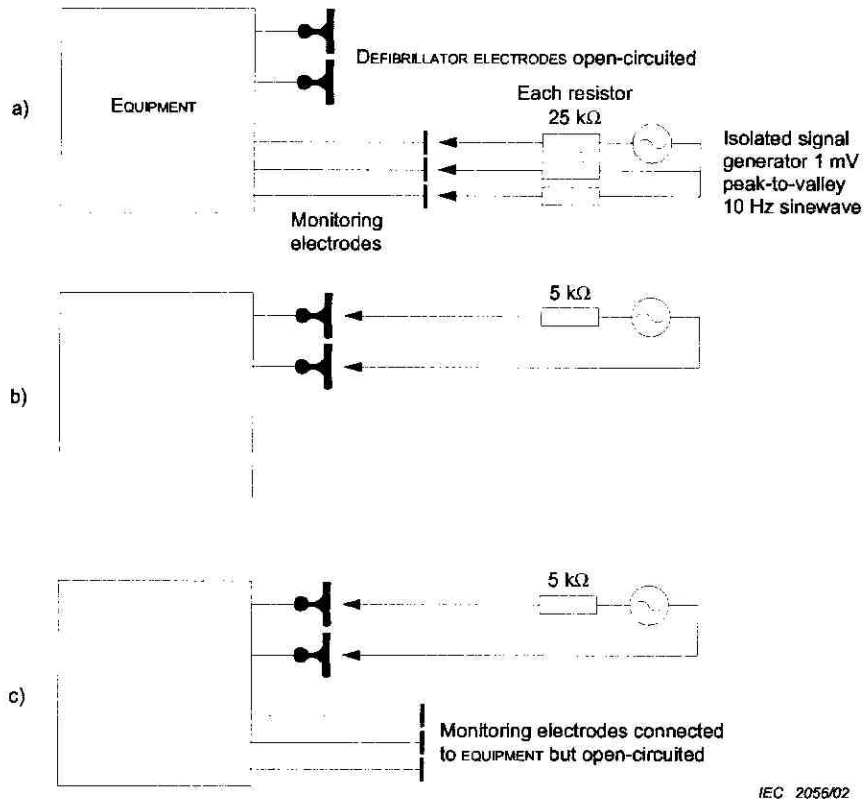

Figure 106 – Arrangement for test of disturbance from charging and internal discharging (see Clause 106)

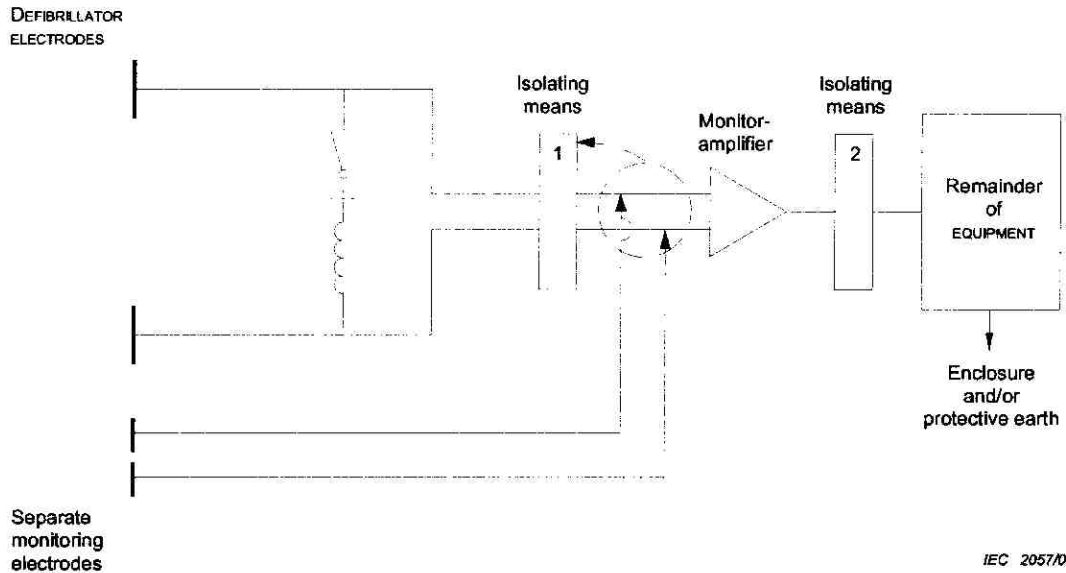
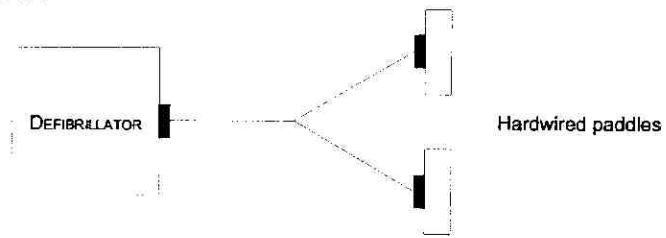
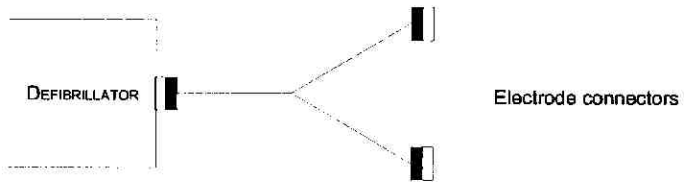

Figure 107 – Isolation of DEFIBRILLATOR circuit from separate monitoring electrodes (see Annex AA, rationale on Clause 20)

Reusable cable and electrodes:



Reusable cable and single use electrodes:



Single use cable and electrode:

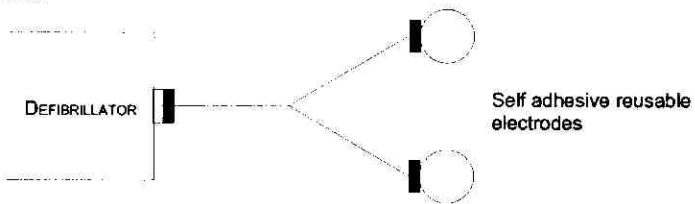

Reusable cable with single electrode and extension cable assembly:

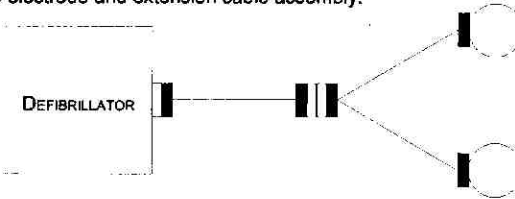

■ Cable anchorage requiring testing

□ Connector to defibrillator or electrode where relevant

Figure 108 – Examples of cord anchorages that require testing

Annexes

The appendices of the General Standard apply except as follows:

Appendix L

References – Publications mentioned in this Standard

This appendix of the General Standard applies except as follows:

Addition:

IEC 60300-3-9, *Dependability management – Part 3: Application guide – Section 9: Risk analysis of technological systems*

IEC 60601-2-27, *Medical electrical equipment – Part 2: Particular requirements for the safety of electrocardiographic monitoring equipment*

IEC 60651, *Sound level meters*

IEC 61000-4-2, *Electromagnetic compatibility (EMC) – Part 4: Testing and measurement techniques – Section 2: Electrostatic discharge immunity test. Basic EMC Publication*

IEC 61000-4-3, *Electromagnetic compatibility (EMC) – Part 4-3: Testing and measurement techniques – Radiated, radio-frequency, electromagnetic field immunity test*

IEC 61000-4-4, *Electromagnetic compatibility (EMC) – Part 4: Testing and measurement techniques – Section 4: Electrical fast transient/burst immunity test. Basic EMC Publication*

IEC 61000-4-5, *Electromagnetic compatibility (EMC) – Part 4: Testing and measurement techniques – Section 5: Surge immunity test*

IEC 61000-4-6, *Electromagnetic compatibility (EMC) – Part 4: Testing and measurement techniques – Section 6: Immunity to conducted disturbances, induced by radio-frequency fields*

IEC 61000-4-8, *Electromagnetic compatibility (EMC) – Part 4: Testing and measurement techniques – Section 8: Power frequency magnetic field immunity test*

Annex AA (informative)

General guidance and rationale

This annex provides a concise rationale for the important requirements of this Standard and is intended for those who are familiar with the subject of the Standard but who have not participated in its development. An understanding of the reasons for the main requirements is considered to be essential for the proper application of the Standard. Furthermore as clinical practice and technology change it is believed that a rationale for the present requirements will facilitate any revision of the Standard necessitated by these developments.

From the standpoint of safety, CARDIAC DEFIBRILLATORS pose special problems not only because of the possible shock hazard to the OPERATOR, but because the DEFIBRILLATOR has to deliver the selected output even after a long period of disuse, otherwise the PATIENT'S safety may be at risk. Thus CARDIAC DEFIBRILLATORS require a high order of reliability.

The minimum safety and reliability requirements as specified in this Standard are considered to provide for an acceptable level of safety in operation and reliability in use.

1.1 Scope

The requirements of this Standard are specified for the commonly used DEFIBRILLATOR with or without an incorporated MONITOR, that is, an EQUIPMENT containing a capacitor as an ENERGY STORAGE DEVICE. This capacitor is charged to a HIGH VOLTAGE and connected to the output electrodes either directly or via a series inductor or resistor.

The first edition of this Standard made a distinction between a DEFIBRILLATOR and a DEFIBRILLATOR-monitor. This was due to development of a draft specification for the latter being developed in parallel with that for DEFIBRILLATORS and the two specifications being combined in a later draft. This distinction is no longer necessary and has been eliminated in this edition.

This Particular Standard does not address requirements for implantable DEFIBRILLATORS since they are considered to have sufficient differences to merit separate treatment.

Since publication of the first edition of this Standard, AUTOMATED EXTERNAL DEFIBRILLATORS (AEDs) have come into widespread use. Several requirements of this Standard have been revised or created to standardize these devices.

A variety of therapeutic waveforms have been used to terminate cardiac fibrillation including damped sine, biphasic, and truncated exponential. DEFIBRILLATOR designers, USERS and evaluators should take into consideration that clinical studies have demonstrated that fibrillator termination efficacy varies widely with waveshape as well as other parameters including voltage amplitude, DELIVERED ENERGY, tilt, and total duration. Waveform technology is evolving rapidly. This precludes stating specific safety requirements in this Standard. However, due to the efficacy sensitivity to variations in these parameters, adequate clinical validation should be considered essential. Particular validation attention should be given to the efficacy of waveforms with insufficient current or protracted duration, and the safety of waveforms with excessive peak current.

4.5 Ambient temperature, humidity, atmospheric pressure

In accordance with the environmental conditions (see 10.2), battery powered EQUIPMENT also has to be type-tested at 0 °C to reveal any temperature-dependent characteristics which may adversely affect safety.

If EQUIPMENT for an extended range of environmental temperatures is needed (for example in ambulances or helicopters) this requires special agreement between the manufacturer and the OPERATOR.

5 Classification

Reference to TYPE B APPLIED PARTS is deleted, as the output circuit has to be isolated from earth to avoid unwanted current paths if the PATIENT has another earth connection. An isolated output circuit is also essential for the safety of the OPERATOR.

6.1 j) Power input

A large surge of current may be drawn from the SUPPLY MAINS during charging of the DEFIBRILLATOR. The OPERATOR should operate the EQUIPMENT on a suitably RATED mains circuit. This is particularly a problem with a DC SUPPLY MAINS.

6.1 aa) Concise operating instructions

As a DEFIBRILLATOR is frequently needed in an emergency situation, the essential operating information has to be available without recourse to the instructions for use.

6.1 bb) Internally powered EQUIPMENT

Here the same rationale as in 6.1 aa) applies. Additionally, the marking should indicate whether the DEFIBRILLATOR with a discharged or missing battery can be used effectively from a built-in or separate battery charger.

6.3 aa)

Values for the PATIENT resistance reported in the literature vary over a range from 25 Ω to 175 Ω in clinical situations. A significant portion of the STORED ENERGY is dissipated in the resistance of the DISCHARGE CIRCUIT or may remain in the storage capacitor. The value of 50 Ω used here represents a suitable reference value rather than a normal or typical value.

In order not to restrict design unnecessarily no stricter requirements regarding numbers of steps are specified. For easy and safe use, all EQUIPMENT is required to be calibrated in joules of DELIVERED ENERGY. However, it is recognized that many newer DEFIBRILLATORS are incorporating sophisticated techniques for optimizing defibrillation output by waveform adjustments based on PATIENT impedance measurements. It is widely recognized that many parameters of defibrillation waveforms, not just total energy, can affect efficacy.

It is an essential safety feature that the OPERATOR can clearly see or hear the charge ready indication from normal distance from PATIENT to device or in typical noise ambient levels. Devices with both audible and visual indicators are preferred.

6.8.2 e), f), g), h)

A rechargeable battery has a limited lifetime and should be replaced periodically.

6.8.2 aa) Supplementary instructions for use

1) and 2) This information is necessary for the protection of OPERATOR and PATIENT as well as of other MEDICAL ELECTRICAL EQUIPMENT. Many AEDs include features to allow defibrillation only if the impedance load falls within a predetermined range, as a safety technique to prevent inappropriate shocks.

- 4) Adverse environmental conditions immediately prior to use may affect the reliable operation of the EQUIPMENT.
- 6) As the reliable function of a DEFIBRILLATOR is essential for the PATIENT's safety, this maintenance is considered important. Inspection of the packaging of disposable electrodes is necessary because the stated conditions could lead to an increase in electrode impedance which may result in degradation in performance of the DEFIBRILLATOR.
- 7) Knowledge of the charging time under best and worst conditions is considered to be essential.

6.8.3 aa)

- 1) As the PATIENT resistance is subject to variation, details of the waveform and the effect of changes in load resistance should be made available to the OPERATOR.
- 2) The data listed for SYNCHRONISER performance is based on problems which have arisen in practice.
- 3) The essential performance of RHYTHM RECOGNITION DETECTORS has been the object of considerable clinical/industry collaboration recently, and has resulted in useful, insightful, and statistically meaningful methods of specifying the performance of such system. The standard should simply adopt the results of these efforts:

Automatic External DEFIBRILLATORS for Public Access Defibrillation: Recommendations for Specifying and Reporting Arrhythmia Analysis Algorithm Performance, Incorporating New Waveforms, and Enhancing Safety, A Statement for Health Professionals From the American Heart Association Task Force on Automatic External Defibrillation, Subcommittee and AED Safety and Efficacy.

10.2 Operation

Extended ranges of temperature and humidity are required since mains-powered as well as INTERNALLY POWERED DEFIBRILLATORS may be used outside medically used rooms. The requirements specified here are intended to cover the majority of environmental conditions likely to be encountered in practical use. However, for special applications, EQUIPMENT having a wider temperature range may be necessary.

14.6 aa)

TYPE CF requirements are necessary, because a DEFIBRILLATOR providing for the connection of SEPARATE MONITORING ELECTRODES may be used for intracardiac monitoring.

17 h)

It is also necessary for the requirement of item bb) of Clause 17 to apply if other PATIENT CIRCUITS of a DEFIBRILLATOR are used and the PATIENT is treated with another DEFIBRILLATOR. The requirements for DEFIBRILLATION-PROOF APPLIED PARTS given in the General Standard generally provide adequate protection for other PATIENT CIRCUITS which have been specifically included in the DEFIBRILLATOR. The amendments given here take account of other APPLIED PARTS which may be connected to the EQUIPMENT but not connected to the PATIENT, in addition to testing with the power off they are tested with power on, which is the normal operating condition.

17 bb)

The severity of electric shock a person receives when touching ACCESSIBLE PARTS during defibrillation is limited to a value which can be felt and which may be unpleasant, but which is not dangerous. SIGNAL INPUT and OUTPUT PARTS are included, as signal lines to remote recording and other EQUIPMENT could otherwise carry voltage surges which could cause hazardous shocks from such EQUIPMENT.

17 cc)

Where the manufacturer has made use of an APPLIED PART at the same time as performing defibrillation impossible, such an APPLIED PART need not be a DEFIBRILLATION-PROOF APPLIED PART.

19.1 General requirements

Due to capacitive coupling between the DEFIBRILLATOR APPLIED PART and other (possibly earthed) parts a certain amount of LEAKAGE CURRENT is unavoidable. During discharge, LEAKAGE CURRENTS may be higher, but will be much smaller than the intended defibrillating pulse current and will not present a SAFETY HAZARD to the PATIENT or the OPERATOR. The period of 1 s for this exemption was chosen in order to include all possible waveforms and to allow any mechanical contactor to reset.

19.3 Allowable values

The lower limit specified in the General Standard is valid for small-area contacts with the myocardium whereas the internal DEFIBRILLATOR ELECTRODES have a relatively large area. Furthermore the SINGLE FAULT CONDITION, i.e. MAINS VOLTAGE on the PATIENT for which this value applies, is unlikely to occur during open-chest surgery.

20 Dielectric strength

Voltage spikes on the SUPPLY MAINS will not appreciably affect the voltage on the energy storage capacitor; therefore a moderate test voltage was considered to be sufficient. In the General Standard earthing of the PATIENT is not considered to be a fault condition; consequently, the situation where one side of the APPLIED PART is connected to earth had to be included.

A high insulation resistance together with the other insulation requirements prevents the appearance of dangerous voltages on conductive ACCESSIBLE PARTS. In most insulating materials a breakdown is preceded by a non-linear increase of the current.

Resistors bridging this insulation should have a value high enough not to conflict with the principle of an isolated DEFIBRILLATOR APPLIED PART.

The purpose of Test 1 is to investigate the insulation between the high-voltage circuit of the DEFIBRILLATOR and other ACCESSIBLE PARTS.

The purpose of Test 2 is to investigate the isolation between the basic wiring and conductive parts of the high-voltage circuit of the DEFIBRILLATOR.

The purpose of Test 3 is to investigate if the isolation across components in the CHARGING CIRCUIT and the DISCHARGE CIRCUIT safely can handle the voltage levels present in the DEFIBRILLATOR.

The high voltage switching elements in a DEFIBRILLATOR provide a barrier between the energy storage element and the PATIENT, and this section is specifically designed to assure the integrity of those switching elements. The essential need is to assure that PATIENT safety is not compromised due to inadvertent energy discharge.

In many traditional DEFIBRILLATOR designs, the switch under test is simply a relay, which either passes the high-voltage test or not. However, newer DEFIBRILLATOR designs may include more complex switching methods. These methods permit for example, the generation of new defibrillation waveforms and provide improved ability to monitor the integrity of the internal systems.

Series-connected switching devices offer useful design advantages in these newer systems, but care must be taken to assure that faults in any one switching element do not lead to compromise of safety. Accordingly, the intent of this requirement is to subject the DEFIBRILLATOR switching system to over-voltage stresses in conjunction with single-fault conditions. The manufacturer must demonstrate that, while gaining the versatility of newer switching techniques, PATIENT safety is not compromised in the event of failure.

36 Electromagnetic compatibility (EMC) requirements

DEFIBRILLATORS are life-saving EQUIPMENT and are often used in the field, or in ambulances, where the electromagnetic environment may be particularly severe. This makes it necessary to expand upon the general requirements of IEC 60601-1-2 in order to provide a reasonable assurance that DEFIBRILLATORS will perform well and safely in all of their intended uses.

Immunity to radiated RF fields is generally insured by requiring that the EQUIPMENT meets all its specifications when exposed to a field strength of 3 Vm^{-1} which is seldom exceeded in hospitals. However, DEFIBRILLATORS used in transport or ambulances are likely to be used in the vicinity of powerful RF sources (mobile radio transmitters, cellular phones,...) where the field strength may reach or exceed 10 Vm^{-1} . An 8 W GSM transmitter, for instance, produces a field of 20 Vm^{-1} at a distance of 1 m. State of the art technology does not ensure that DEFIBRILLATORS meet all specifications in the presence of a modulated 10 Vm^{-1} RF field but a minimum safety requirement is that such intense fields should not result in a SAFETY HAZARD.

Examples of SAFETY HAZARDS include failures involving changes in operating state (e.g., unintended charge or discharge), irrecoverable loss or change of stored data, or clinically serious errors in control software (e.g., unintended change in discharge energy level).

42 Excessive temperatures

The operating conditions specified in 42.3 are considered to represent the most severe operating conditions liable to occur in practical use.

44.6 Ingress of liquids

The EQUIPMENT is likely to be carried and used outside medically used rooms and therefore a certain degree of protection against rainfall and spillage was deemed to be necessary. During the functionality test of the DEFIBRILLATOR it is allowed that secondary functionality (e.g. a recorder) does not operate after the test, as long as this does not adversely affect the DEFIBRILLATOR functionality.

Especially for AEDs it is required that voice prompts (if applicable) are still functional after the test.

For some EQUIPMENT there may be more than one position of NORMAL USE.

44.7 Cleaning, sterilization and disinfection

This requirement was deemed to be essential as the internal DEFIBRILLATOR ELECTRODES are used during open-chest surgery.

46.101 a)

The simultaneous energizing of two pairs of electrodes would create a SAFETY HAZARD.

46.101 b)

This safety requirement may be fulfilled by a design employing a recessed push-button or by similar means. In view of the difficulty of producing a sterilizable internal electrode containing a momentary switch in the electrode handle, a push-button on the panel was deemed to be satisfactory. Furthermore, it may be operated by an assistant during open-chest surgery. The risk of accidental operation of a foot switch is considered unacceptable. Example 4) addresses the advent of self-adhesive DEFIBRILLATOR ELECTRODES since the first edition of this Particular Standard and presents the same degree of safety as example 2).

46.103

Adequate OPERATOR warning prior to discharge is important. However, it is possible to charge safely even though discharge may not be imminent. Because charging may be an internal "background" function of the device, it is more important to the OPERATOR to be warned of impending external events, such as energy delivery. Of more relevance to the OPERATOR are:

- a) The DEFIBRILLATOR senses a "shockable" rhythm and reaches a "shock" decision. This decision needs to be announced by voice or other audible or visual warning to the OPERATOR. This announcement allows the OPERATOR and any bystanders to prepare for the shock.
- b) If the DEFIBRILLATOR is of the "advisory" type, further audible warnings are needed when the DEFIBRILLATOR becomes fully armed and ready to shock.
- c) If the DEFIBRILLATOR is fully automatic, voice or warning sound warnings at least 5 s prior to discharge are needed to allow time to cease touching the PATIENT.)

50 Accuracy of operating data

Many quite different waveforms are currently used for the treatment of cardiac dysrhythmias. The energy levels used with these different waveforms also vary widely and there is at present no general agreement in the medical profession on an optimum form of electrical output for a CARDIAC DEFIBRILLATOR. This Standard therefore does not specify output parameters in any detail.

50.1 Marking of controls and INSTRUMENTS

Some standby DEFIBRILLATORS are simple, single energy devices. As long as the accuracy of the device is within the provisions of this Standard, no advantages are available to the OPERATOR from a quantitative DELIVERED ENERGY indication.) Also, most AEDs have a programmed sequence of energy settings, precluding the OPERATOR from energy selection during PATIENT use. Therefore, a SELECTED ENERGY control is not appropriate.

50.2 Accuracy of controls and INSTRUMENTS

The specified accuracy is considered adequate and is practical with existing technology. It was noted that the accuracy tolerance is quite broad for lower energy selections (e.g. <10 J) It is important that an increase (or decrease) in SELECTED ENERGY produce a corresponding increase (or decrease) in DELIVERED ENERGY. The absolute accuracy of the DELIVERED ENERGY is somewhat less important. DEFIBRILLATORS should meet the output accuracy requirements even when the USER waits for a while before deciding to deliver a shock.

When the standard was first written, most defibrillators used a damped sinusoidal waveform. Consequently the DELIVERED ENERGY (for a given STORED ENERGY) increased with PATIENT impedance which may range from 25 to 175 Ω . For example, with a DEFIBRILLATOR internal impedance of 10 Ω and a DELIVERED ENERGY into 50 Ω equal to ED_{50} , the DELIVERED ENERGY into 25 Ω is 0,86 ED_{50} , into 100 Ω is 1,09 ED_{50} , into 175 Ω is 1,135 ED_{50} . If the DEFIBRILLATOR interval impedance were 15 Ω , the range would be 0,81 ED_{50} to 1,20 ED_{50} , i.e. $\pm 20\%$ of ED_{50} . This variation is systematic, reproducible and easily calculated and verified. Hence in the previous standard the required energy accuracy was $\pm 15\%$ at 50 Ω , and $\pm 30\%$ over the whole

56.101 b)

These requirements are specified because in practice the cables and their anchorages are subject to considerable stress. The cables of external paddles have several lines; therefore, if required to meet the test for internal cables, they would become thick and lose flexibility.

57.10 aa)

Relatively large distances are specified to allow for the probable spread of conductive jelly.

57.10 bb)

Voltage spikes on the MAINS VOLTAGE will not significantly influence the voltage on the storage capacitor; therefore relatively small distances are considered to provide enough safety.

57.10 cc)

Non-reusable DEFIBRILLATOR ELECTRODES are not required to comply with the creepage and clearance requirements of bb above and are not required to comply with the dielectric strength requirements of 20.

57.10 dd)

Double insulation for reusable cables that may become worn with time and rough handling provides a margin of safety for the OPERATOR to protect from high voltage exposure. For single use cables of moderate length, this risk is remote and the requirement is relaxed.

101 Charging time

A delay in delivery of shock is undesirable: even under unfavourable conditions, an excessively long charging time is not acceptable. The time from power-on to having this energy ready becomes a significant problem where self-diagnostics on power-on take more time and check more facilities, particularly when they are repeated if the system re-boots. From within any USER programming mode (once starting to adjust filter settings for instance), if the software were to require completion of a lengthy procedure before returning to normal mode this could lead to further delays.

101.1 – 101.4

When EQUIPMENT has indicated that a non-rechargeable battery needs replacement, the DEFIBRILLATOR should be able to comply with the requirements specified in Clause 101.1-101.4.

101.3 – 101.4

Due to requirements of a 5 s audible tone or voice prior to energy delivery for fully AUTOMATED EXTERNAL DEFIBRILLATORS (see 46.101 c)) the charge time requirement in 101.3 and 101.4 actually tightens the requirements for fully AUTOMATED EXTERNAL DEFIBRILLATORS.

101.3 b)

The 40 s requirement is derived from the following assumptions: 10 s self-test + 15 s ECG-analysis +15 s charge time. In many cases the background analysis should be confirmed by a manually activated analysis period where the charging of the ENERGY STORAGE DEVICE is started during this manually started analysis.

102.2 – 102.3

This minimum battery capacity is a compromise between number of discharges and portability.

The test assumes that operational EQUIPMENT is normally stored and charged at room temperature but may need to be used at colder temperatures. Battery powered EQUIPMENT should be tested at 0 °C, the lowest temperature specified in the environmental conditions (see 10.2) to reveal temperature-dependent deficiencies.

The requirements should be fulfilled in the situation where the battery has been charged at minimum and maximum temperature as specified in 10.2.1 (minimum 0 – 40 °C or according to manufacturers instructions in the accompanying documents). This is due to the fact of charge acceptance for batteries at various temperatures. It is reasonable to expect that the battery will be charged in environments varying between 0 °C and 40 °C (or at the limits set by the manufacturer).

102.2 Requirements for MANUAL DEFIBRILLATORS

For INFREQUENT USE DEFIBRILLATORS it can not be required to perform three defibrillations in 1 min, since the charging time from discharge No. 7 – 5 should be within 25 s (see 101.2). The 90 s will assure a break between each of the three discharges and “recovery” of the battery.

102.3 Requirements for automated external defibrillators

This measure is the best way to look at the shock-to-shock cycle time of an AED, since the ECG analysis period will always be included in the total time required to deliver a shock. Hence the modification of 1 min to 105 s and 135 s for AEDs with respect to manual DEFIBRILLATORS in order to simulate a PATIENT remaining in VF, which the AED analyses and shocks repeatedly (up to 3 times) as quickly as possible. Requiring a shorter “charge and shock” time is inconsistent with the operation of AEDs, since the ECG analysis must be performed as part of the process. The 1 min rest period is consistent with current AHA CPR guidelines.

102.4

This requirement is specified to avoid unexpected depletion of the battery.

102.6

Rechargeable batteries should provide for a satisfactory number of discharges after a week's storage without recharging the battery. This requirement is specified to avoid unexpected depletion of the battery.

103 Endurance

As reliability of the EQUIPMENT has important safety implications, an endurance test is necessary.

Discharge of the DEFIBRILLATOR into open- or short-circuited electrodes is considered to be misuse. Nevertheless it may occur in practical use and hence the DEFIBRILLATOR should be able to withstand a limited number of such operations. Where such misuse is not possible, the relevant short- and/or open-circuit test is unnecessary.

104 Synchronizer

As different synchronization systems exist, only features influencing safety are specified:

- 1) It has to be clearly apparent if the DEFIBRILLATOR is in the synchronized mode; otherwise operation in an emergency is delayed.
- 2) The discharge has to be under the full control of the OPERATOR.
- 3) This requirement is based on ANSI/AAMI DF2-1989 (4.3.17). The reduced time permitted for an ECG derived by another EQUIPMENT allows for up to 35 ms processing/detection prior to signaling to the DEFIBRILLATOR.
- 4) As a safety feature, the DEFIBRILLATOR should always enter a mode where synchronization is disabled after power-on or when the DEFIBRILLATOR mode is entered from a mode different from the DEFIBRILLATOR mode.

A DEFIBRILLATOR and a monitor are normally needed to perform synchronized cardioversion. It is strongly recommended that the defibrillator monitor be integrated into a single instrument to ensure proper interfacing. However such integrated instruments are not available everywhere, and a separate defibrillator and a stand-alone monitor will inevitably be used in many instances. In such cases the USER is responsible for exercising proper care and for ensuring that the two instruments are properly interfaced and satisfy the timing requirements for safe synchronized cardioversion.

105 Recovery of the MONITOR/ECG input after defibrillation

In order that the success or failure of an attempt to defibrillate a PATIENT may be determined as soon as possible, a rapid recovery is necessary from the amplifier overload and electrode polarization produced by the pulse. This applies with the monitoring signal derived via the DEFIBRILLATOR ELECTRODES or via any SEPARATE MONITORING ELECTRODES.

106 Disturbance to the MONITOR from charging or internal discharging

The requirements allow for a level of interference which is unlikely to cause difficulties in interpretation of the ECG display.

Annex BB (informative)

AUTOMATED EXTERNAL DEFIBRILLATORS: background and rationale

Approximately 40,000 AUTOMATED EXTERNAL DEFIBRILLATORS (AED) have been sold since they were first introduced on the market in the 1980's. If current studies evaluating the possible expansion of AED applications are completed, the potential market for AEDs will be several hundred thousand, larger than the market for conventional DEFIBRILLATORS.

Persons using AEDs generally have little or no training or medical skills, hence a standard is particularly needed to set requirements which ensure that AEDs are effective and safe.

Rationale for different types of AEDs

Sudden cardiac arrest (SCA) strikes approximately 350,000 persons every year in the USA, and a comparable number in Europe. In cardiac arrest, blood flow ceases. After 5 min to 10 min, the brain suffers significant damage due to oxygen deprivation, and death occurs after 10 min to 20 min. Cardiopulmonary resuscitation (CPR) can perhaps double these times, but does not change the outcome. Defibrillation is the only method for terminating cardiac arrest due to ventricular fibrillation (VF) and restoring blood flow, and effective DEFIBRILLATORS have been commercially available for 30 years. We do not know how to predict or prevent sudden cardiac arrest, which strikes without warning any time in the day (though more often in the early morning), at home, at work, outdoors etc., i.e. away from a hospital.

Conventional DEFIBRILLATORS can only be used by medical professionals skilled in analysing an electrocardiogram and determining whether or not a PATIENT shall be defibrillated. In the 1960's ambulances were dispatched to the site of a presumed victim of cardiac arrest. If cardiac arrest was verified, the victim received drugs and CPR and was transported to a hospital for defibrillation. Time in cardiac arrest was very long and survival rate was extremely low, 1-3 %, making cardiac arrest the leading cause of death for adults aged 30 to 60 years.

In the 1970's it became clear that survival rate was very high (average 60 % to 80 %) if defibrillation was attempted within 1-2 min of the onset of VF, but decreased rapidly with increasing time in VF, about 7 % per minute without CPR, and 3 % to 4 % per minute with CPR.

The concept of the "chain of survival", developed in the early 1980's, states that high survival rate from SCA requires:

- early recognition of SCA and access to the PATIENT;
- early CPR;
- early defibrillation;
- early Advanced Cardiac Life Support.

To achieve the 3rd and critical step, early defibrillation, highly trained paramedics were allowed to defibrillate beginning in the 1970's. Several years later, emergency medical technicians (EMT) received special training so they could analyse electrocardiograms and defibrillate using conventional DEFIBRILLATORS.

The next step in achieving earlier defibrillation was to advocate development of smart DEFIBRILLATORS (AEDs) which could analyse the ECG and determine whether defibrillation was needed, hence allowing use by people without electrocardiogram training. AEDs would be placed in every ambulance and in vehicles used by "first responders" such as firemen or police. The American Heart Association (AHA) published this statement in 1991.

To achieve the goal of early defibrillation, the AHA endorses the position that all emergency personnel shall be trained and permitted to operate an appropriately maintained DEFIBRILLATOR if their professional activities require that they respond to persons experiencing cardiac arrest. This includes all first responding emergency personnel, both hospital and non hospital (e.g., emergency medical technicians (EMTs), non-EMT first responders, firefighters, volunteer emergency personnel, physicians, nurses, and paramedics).

To further facilitate early defibrillation, it is essential that a DEFIBRILLATOR be immediately available to emergency personnel responding to a cardiac arrest. Therefore, all emergency ambulances and other emergency vehicles, that respond to or transport cardiac PATIENTS shall be equipped with a DEFIBRILLATOR.

Since 1993, the AHA has begun promoting the ultimate step in early defibrillation, "Public Access Defibrillation" (PAD) in which extremely simple, low cost, intuitive use, fully automatic AEDs are deployed in a variety of office buildings, factories, shopping malls, concert halls etc. and can be used if needed by any bystander or lay person witnessing a possible cardiac arrest. This is still a developing concept not yet implemented, but with the support of AHA, the prospect of large scale implementation of PAD in 3-5 years is plausible.

This discussion makes it clear that 3 types of AEDs are needed:

- 1) AEDs for hospitals and ambulances. Will be used fairly frequently (possibly several times per week) by medically trained personnel. Must be sophisticated, very rugged. May offer several modes of operation and a variety of features. Must be advisory rather than automatic. May require periodic OPERATOR tests and a schedule of preventive maintenance due to complexity and frequency of use.
- 2) AEDs for first responders such as firemen, police officers and security officers will be used less frequently (a few times per month or less). These AEDs must be reliable in making shock recommendations and generally rugged due to the various environments outside of the hospital where they are needed. They must be very simple to use to allow for greater numbers of emergency response personnel to be trained with minimal time and skill retention. They shall perform automatic periodic tests to verify fitness for use, and minimize and/or automate maintenance to the greatest extent possible.
- 3) AEDs for PAD or placement in the house of a high risk survivor of cardiac arrest or heart attack. These devices will be used very infrequently (perhaps once a year) must be very inexpensive and preferable very light, must be simple enough for use by a lay person, are fully automatic and have a sophisticated schedule of fully automated functional tests, maintenance and recalibration if needed.

Clearly these three types of AEDs are different in design and features, and it is necessary to differentiate requirements in some parts of the standard. The main differentiation is associated with frequency of use and skill of the USER.





Standards Survey

The IEC would like to offer you the best quality standards possible. To make sure that we continue to meet your needs, your feedback is essential. Would you please take a minute to answer the questions overleaf and fax them to us at +41 22 919 03 00 or mail them to the address below. Thank you!

Customer Service Centre (CSC)

International Electrotechnical Commission

3, rue de Varembé
1211 Genève 20
Switzerland

or

Fax to: **IEC/CSC** at +41 22 919 03 00

Thank you for your contribution to the standards-making process.

A Prioritaire

Nicht frankieren
Ne pas affranchir



Non affrancare
No stamp required

RÉPONSE PAYÉE

SUISSE

Customer Service Centre (CSC)
International Electrotechnical Commission
3, rue de Varembé
1211 GENEVA 20
Switzerland





ISBN 2-8318-6552-2



9 782831 865522

ICS 11.040.10

Typeset and printed by the IEC Central Office
GENEVA, SWITZERLAND