



Standard Specification for Capnometers¹

This standard is issued under the fixed designation F 1456; the number immediately following the designation indicates the year of original adoption or, in the case of revision, the year of last revision. A number in parentheses indicates the year of last reapproval. A superscript epsilon (ϵ) indicates an editorial change since the last revision or reapproval.

INTRODUCTION

The measurement of carbon dioxide in a gaseous mixture has become a common practice in many areas of clinical medicine, such as anesthesia, respiratory therapy, pediatrics, and intensive care. This draft specification establishes minimum safety and performance requirements for capnometers based on parameters that are achievable within the limits of existing technology.

Appendix X1 contains a rationale for the most important requirements. It is included to provide additional insight for the reasoning that led to the requirements and recommendations that have been incorporated into this draft specification.

This draft specification references IEC 601-1:1988 (hereafter referred to as the General Standard) for many of the general requirements for safety. Requirements specific to capnometers begin at Clause 60.

1. Scope

1.1 The scope given in Clause 1 of the General Standard applies except that 1.1 shall be replaced by the following:

1.1.1 This specification specifies requirements for the safety and performance of capnometers as defined in Subclause 3.5. It applies to capnometers used with adults, children, and neonates.

1.1.2 It does not apply to devices solely intended for use as cutaneous monitors.

1.1.3 Capnometers intended for use in laboratory research applications are outside the scope of this specification.

2. Referenced Documents

2.1 The following standards contain provisions which, through reference in this text, constitute provisions of this specification. At the time of publication, the editions indicated were valid. All standards are subject to revision, and parties to agreements based on this specification are encouraged to investigate the possibility of applying the most recent editions of the standards listed below.

2.2 ASTM Standards:

F 1054 Specification for Conical Fittings of 15 mm and 22 mm sizes²

F 1463 Specification for Alarm Signals in Medical Equipment Used in Anesthesia and Respiratory Care³

2.3 ISO Standards:³

ISO 32:1977 Gas Cylinders for Medical Use—Marking for Identification of Contents

ISO 5356/1:1987 Anaesthetic and Respiratory Equipment—Connectors, Part I: Cones and Sockets

ISO 5356/2:1987 Anaesthetic and Respiratory Equipment—Connectors, Part II: Screw-Threaded-Weight-Bearing Connectors

ISO 7249 Controls—Terms, Suitability, Design Requirements

ISO 7250 Basic List of Anthropomorphic Measurements

2.4 IEC Standards:³

IEC 65:1985 Safety Requirements for Mains Operated Electronic and Related Apparatus for Household and Similar Use

IEC 79-3:1972 Electrical Apparatus for Explosive Atmospheres—Part III: Spark Test Apparatus for Intrinsically Safe Units

IEC 79-4:1975 Electrical Apparatus for Explosive Gas Atmospheres—Part IV: Method of Test for Ignition Temperature

IEC 601-1:1988 Safety of Medical Electrical Equipment—Part I: General Safety Requirements

IEC 801-2:1991 Electromagnetic Compatibility for Industrial-Process Measurement and Control Equipment—Part 2: Electrostatic Discharge Requirements

3. Terminology

3.1 *Definitions*—For the purposes of this specification, the definitions given in Clause 2 of the General Standard apply, along with the following definitions:

3.1.1 *accuracy*—the quality that characterizes the ability of a device to give indications approximating to the true value of

¹ This specification is under the jurisdiction of ASTM Committee F-29 on Anesthetic and Respiratory Equipment and is the direct responsibility of Subcommittee F29.03 on Division Three on Ventilators and Ancillary Devices.

Current edition approved December 15, 1992. Published June 1993.

² *Annual Book of ASTM Standards*, Vol 13.01.

³ Available from American National Standards Institute, 1430 Broadway, New York, NY 10018.

the quantity measured.

3.1.2 *alarm*—a warning signal.

3.1.3 *alarm set point*—the setting of the adjustment control, or display value, which indicates the carbon dioxide reading, at or beyond which the alarm is intended to be activated.

3.1.3.1 *Discussion*—Terms such as “alarm limits” or “alarm threshold” are frequently used to describe the same function.

3.1.4 *alarm system*—those parts of the capnometer which: (1) establish the alarm set point(s); and (2) activate an alarm when the carbon dioxide reading is less than or equal to the low-alarm set point, if provided, or is equal to or greater than the high-alarm set point.

3.1.5 *capnometer*—a device for the measurement of carbon dioxide concentration or partial pressure in ventilatory gases.

3.1.5.1 *Discussion*—The capnometer consists of all equipment including accessories, sensor, and sampling tubing (if a diverting capnometer) specified by the manufacturer for the intended use of the capnometer.

3.1.6 *carbon dioxide level*—the concentration of carbon dioxide in gaseous mixture.

3.1.6.1 *Discussion*—This may be expressed in any suitable unit such as percent by volume or partial pressure in kPa (or mm Hg).

3.1.7 *carbon dioxide reading*—the measured carbon dioxide level as indicated by the capnometer display.

3.1.8 *cutaneous oxygen and carbon dioxide partial pressure monitoring equipment*—equipment or associated transducers, or both, for the monitoring or recording, or both, of partial pressures of oxygen and carbon dioxide at the skin surface.

3.1.9 *delay time*—the time from a step function change in CO₂ concentration or partial pressure at the sampling site to the achievement of 10 % of final CO₂ value in the capnometer (see Fig. 1).

3.1.10 *display*—the visual representative of output data.

3.1.11 *diverting capnometer*—a capnometer that transports a portion of respired gases from the sampling site through a sampling tube to the sensor, which is remote from the patient.

3.1.12 *high-priority alarm*—an indication of danger and meaning that immediate action on the part of the operator is required.

3.1.13 *interference with measurement accuracy*—the difference between the carbon dioxide reading in the presence of an interfering gas mixture and the carbon dioxide reading in a corresponding mixture in which the interfering gas or vapor fraction has been replaced by nitrogen.

3.1.14 *low-priority alarm*—an indication of a condition that

requires awareness on the part of the operator, but not necessarily action.

3.1.15 *medium-priority alarm*—an indication meaning that prompt action on the part of the operator is required.

3.1.16 *non-diverting capnometer*—a capnometer that uses a sensor at the sampling site.

3.1.17 *oxygen level*—the concentration of oxygen in a gaseous mixture.

3.1.17.1 *Discussion*—This may be expressed in any suitable unit such as percent by volume or partial pressure in kPa (or mm Hg).

3.1.18 *partial pressure*—the pressure that each gas in a gas mixture would exert if it alone occupied the volume of the mixture at the same temperature.

3.1.19 *percent (%) v/v carbon dioxide (or other gases)*—the level of carbon dioxide (or other gas) in a mixture, expressed as a percent volume fraction.

3.1.20 *rise time*—the time required to achieve a rise from 10 to 90 % of the final CO₂ value in the capnometer when a step function change in CO₂ concentration or partial pressure occurs at the sampling site (see Fig. 1).

3.1.21 *sampling site*—the location at which respiratory gases are diverted for measurement to a remote sensor in a diverting capnometer or the location of the sensor area in a non-diverting capnometer.

3.1.22 *sampling tubing*—the conduit for transfer of respiratory gases from the sampling site to the sensor in a diverting capnometer.

3.1.23 *sensor*—the part of the capnometer that is sensitive to the presence of carbon dioxide.

3.1.24 *sensor area*—the part of the sensor at which carbon dioxide is detected.

3.1.25 *total system response time*—the sum of the delay time and the rise time (see Fig. 1).

3.1.26 *transducer*—a device for converting the partial pressure or concentration of a gas into a signal for monitoring or recording.

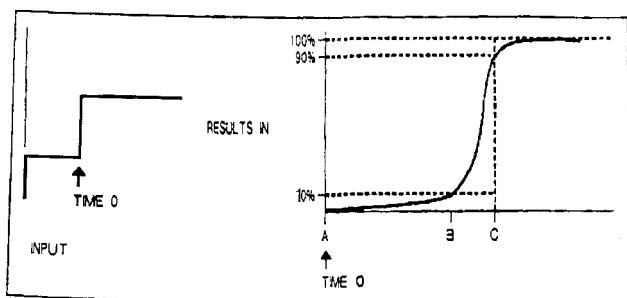

FIG. 1 Response Time (Total System Response)

4. Relationship of This Specification to the General Standard

	Section One—General		
	(A)	(NA)	(AM/R) ⁴
1. Scope and object			X
2. Terminology and definitions			X
3. General requirements			X
4. General requirements for tests			X
5. Classification	X		
6. Identification, marking and documents			X
7. Power input	X		
Section Two—Environmental Conditions			
8. Basic safety requirements (not used)			
9. Removable protective means (not used)			
10. Environmental conditions	X		
11. Special measures with respect to safety (not used)			
12. SINGLE FAULT CONDITION (not used)			
Section Three—Protection Against Electric Shock Hazards			
13. General			X
14. Requirements related to classification			X
15. Limitation of voltage and/or energy			X
16. Enclosures and PROTECTIVE COVERS			X
17. Separation			X

18. Protective earthing, functional earthing, and potential equalization	X	
19. Continuous LEAKAGE CURRENTS and PATIENT AUXILIARY CURRENTS		X
20. Dielectric strength	X	

Section Four—Protection Against Mechanical Hazard

21. Mechanical strength		X
22. Moving parts	X	
23. Surfaces, corners, and edges	X	
24. Stability in NORMAL USE	X	
25. Expelled parts	X	
26. Vibration and noise (not used)		
27. Pneumatic and hydraulic power	X	
28. Suspended masses	X	

Section Five—Protection Against Hazards from Unwanted or Excessive Radiation

29. X-radiation	X	
30. Alpha, beta, gamma, neutron radiation and other particle radiation	X	
31. Microwave radiation	X	
32. Light radiation (including lasers)	X	
33. Infra-red radiation	X	
34. Ultra-violet radiation	X	
35. Acoustical energy (including ultrasonics)	X	
36. Electromagnetic compatibility		X

Section Six—Protection Against Hazards of Ignition of Flammable Aesthetic Mixtures

37. General	X	
38. Marking, ACCOMPANYING DOCUMENTS	X	
39. Common requirements for Category AP and Category APG EQUIPMENT	X	
40. Requirements and tests for Category AP EQUIPMENT, parts or components thereof	X	
41. Requirements and tests for Category APG EQUIPMENT, parts or components thereof	X	

Section Seven—Protection Against Excessive Temperatures and Other Safety Hazards

42. Excessive temperatures	X	
43. Fire prevention		X
44. Overflow, spillage, leakage, humidity, ingress of liquids, cleaning, sterilization, and disinfection		X
45. Pressure vessels and parts subject to pressure	X	
46. Human errors		X
47. Electrostatic charges	X	
48. Materials in APPLIED PARTS in contact with the body of the PATIENT	X	
49. Interruption of the power supply	X	

Section Eight—Accuracy of Operating Data and Protection Against Hazardous Output

50. Accuracy of operating data (not used)		
51. Protection against hazardous output		X

Section Nine—Abnormal Operation and Fault Conditions; Environmental Tests

52. Abnormal operation and fault conditions	X	
53. Environmental tests	X	

Section Ten—Constructional Requirements

54. General	X	
55. ENCLOSURES and covers	X	
56. Components and general assembly	X	
57. MAIN PARTS, components and layout	X	
58. Protective earthing—terminals and connections	X	
59. Construction and layout	X	

Additional Clauses

60. Interfering gas and vapor effects other than water vapor	X	
--	---	--

61. Sustained pressure	X
62. Gas leakage and sampling loss	X
63. Connectors	X

^A A = applies, NA = not applicable, and AM/R = applies with an amendment, addition, or revision to the requirement in the General Standard.

5. Clauses Containing Amendments, Additions, or Replacements to the Text in IEC 601-1:1988

NOTE 1—The clause numbers used reference the specific section in the General Standard.

4. *General Requirements and General Requirements for Tests*—Clauses 3 and 4 of the General Standard apply together with the following additions:

4.12 Test methods other than those specified in this draft specification, but of equal or greater accuracy, may be used to verify compliance with the requirements of this draft specification. However, in the event of dispute, the methods specified in this draft specification shall be used as the reference methods.

4.13 Components of the capnometer should be made of materials that are compatible with the gases and agents with which those components are designed to come into contact.

6. *Identification, Marking, and Documents*—The requirements given in Clause 6 of the General Standard apply together with the following additions and modifications:

(1) In the preamble to Clause 6, replace the first item under “clearly legible” by the following:

Warning statements, instructive statements, or drawings: affixed in a permanent location and legible to a user with a visual acuity of 1.0 (corrected if necessary) from a distance of 1 m at an illuminance level of 215 lx.

(2) In 6.1, replace item (d) by the following:
If the size of the capnometer does not permit the complete marking as specified throughout this clause, at least the following shall be marked on the capnometer: the name of the manufacturer, a serial or lot or batch identifying number, and Symbol 14 in Table D1 of the General Standard.

(3) In 6.1, add the following to item (f): a serial number or other lot or batch identifier.

(4) In 6.1, add the following to item (g): the words “not for use in breathing systems,” if applicable.

(5) In 6.1, add additional items as follows:
(zz) Marking on the capnometer shall additionally include the following:

(a) For capnometers not for use with inhalational anesthetic agents, the phrase “not for use with inhalation anesthetic agents,” if applicable.

(b) If moisture has an adverse effect on performance, either a statement that the operator or user shall see the accompanying documents for the effect of moisture on accuracy, or Symbol 14 in Table D1.

(c) Abridged operating instructions for those capnometers that are intended as “free standing” types of devices.

(d) *Other Sources of Interference*—The manufacturer shall mark the device with a warning to refer to the accompanying documents or Symbol 14 in Table D1 of the General Standard for the expected adverse effects on the performance of the capnometer when exposed to electrocautery, electrosurgery, defibrillation, X-ray (gamma radiation) infra-red radiation,

conducted transients, magnetic fields (that is, magnetic resonance imaging (MRI)), and radiofrequency interference known at the time of preparation of the accompanying documents.

NOTE 2—It is recommended that illustrated service information be provided to include the following: instructions for preventive maintenance and service calibration, and those adjustments that are necessary to maintain the capnometer in the correct operating condition, as well as a description of those adjustments and replacements that can be performed by the user.

(6) Clause 6.7 of the General Standard shall apply with the following modifications:

(a) Dot matrix, alphanumeric displays, and computer-generated graphics are not considered to be indicator lights.

(b) Compliance shall be checked by functional tests and inspections.

(7) In 6.8.2, add the following to item (a): The instructions for use shall additionally include the following information:

(a) A description of the purpose and intended use of the capnometer.

(b) A description of the principles of operation of the capnometer, including the relationship between gas concentration and its partial pressure, and the quantitative effects of humidity.

(c) A detailed specification including the following:
The carbon dioxide measurement range and the accuracy of measurement;

If gas diversion occurs, the gas diversion flow;

The stability of measurement accuracy;

The rise time;

The carbon dioxide level alarm range and its accuracy;

The operating and non-operating (storage) temperature ranges;

For sampling type capnometers, the gas diversion rate;

Power requirements; and

Time from switching on to obtaining specified operating performance.

(d) Details of any adverse effect on stated function due to the following:

Humidity or condensate, including, for example, any adverse effects if an adaptor is provided to improve the function of the sensor in the presence of condensation or particulate water;

Interfering gases or vapors;

Mechanical shock;

Cyclic pressure;

Barometric pressure or pressure at the site of use of the capnometer;

Fluctuation in line or battery voltage; and

If automatic compensation for barometric pressure is not provided, then the accompanying documents shall contain an explanation that the readings in concentration units are correct only under the pressure at which the capnometer is calibrated.

(e) An illustration of the features of the capnometer, indicating the location of all operating controls, adjustments, and system components necessary for correct operation.

(f) Instructions for operation of the capnometer, including the following:

Checking and calibration before use;

Routine inspection and testing; and
Recommended methods for cleaning and disinfection or sterilization.

(g) A description of an in-service test using a recommended test gas as the calibration gas.

(h) A description of the correct installation of the capnometer and a detailed description of sampling arrangements and any connecting tubing.

NOTE 3—If the capnometer requires a sensor cable or sampling tubing for connection from the capnometer to the sensing area, the cable or tubing should be of sufficient length to reduce the likelihood of its being elongated beyond its elastic limit and being stressed at the point or connection.

19. *Continuous Leakage Currents and Patient Auxiliary Currents*—The requirements given in Clause 19 of the General Standard apply except as follows:

(1) In item 19.1(e), add the following:

(a) For non-diverting capnometers at the sensor; and

(b) For diverting capnometers, at the junction of the sampling tubing and the body of the capnometer.

NOTE 4—Sampling tubing usually non-conducting. Input port most likely to represent an electrical hazard.

(2) Where national standards mandate more restrictive limits, these more restrictive limits shall apply.

21. *Mechanical Strength:*

(1) The requirements given in Clause 21 of the General Standard are replaced by the following:

21.1 Free-standing capnometers (that is, those not intended for use as an integral inseparable component of a larger system) and all separable components, such as sensors, shall be able to withstand mechanical shock and vibration, such that electrically live parts shall not become accessible.

(2) Compliance shall be checked by the test given in 21.7.

21.7 *Method of Test:*

21.7.1 *Principle*—The accuracy of the carbon dioxide reading, the rise time, and, if applicable, the alarm accuracy are determined after the capnometer and all separable components have been subjected to a mechanical shock.

21.7.2 *Procedure:*

(1) Attach the unpackaged items to be tested rigidly to a shock table machine. Apply three shocks in both directions along three mutually perpendicular axes of each test item (a total of 18 shocks to each item), taking care to ensure the following:

(a) That the shape of the shock pulse is in accordance with Fig. 2;

(b) That the acceleration amplitude (A) of the ideal half-sine pulse is 300 m/s² (30 × gravity) and its duration (D) is 11 ms.

(c) That the oscillogram of the shock pulse includes a time approximately 33 ms (3 × D) long;

(d) That the measured acceleration pulse is contained between the broken-line boundaries shown in Fig. 2;

(e) That the measured velocity change (which may be obtained by integration of the acceleration pulse) is within the limits $V_i \pm 0.1 V_i$, where the velocity change associated with the ideal pulse is $V_i = 2 \times A \times D / 3.1416 = 2 \times 300 \times 0.011 / 3.1416 = 2.1 \text{ m/s}$; and

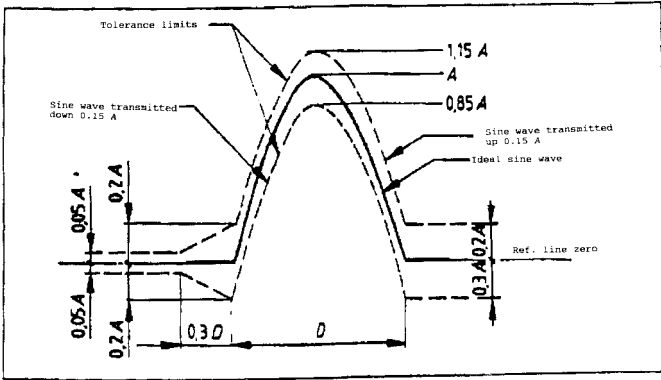

FIG. 2 Half Sine Shock Pulse Configuration and Its Tolerance Limits

(f) That the integration to determine velocity change extends from 4.4 ms (0.4 D) before the pulse to 1.1 ms (0.1 D) after the pulse.

(2) Inspect the capnometer to check that the appearance and condition of the capnometer, including the enclosure and warning or display indications or markings, have not been damaged or have not deteriorated in such a way as to prevent normal operation of the capnometer and that no electrically live parts have become accessible.

(3) Reattach any separable components to the capnometer and conduct the test for measurement accuracy as described in Clause 50.2 and the test for rise time as described in Clause 50.5 and, if the capnometer is fitted with a carbon dioxide level alarm, the test for carbon dioxide level alarm set point as described in Clause 51.4.9.

21.7.3 *Expression of Results*—Express the results as described in the relevant subclauses of Clause 51 and report any damage or the accessibility of live parts.

26. *Vibration and Noise:*

26.1 *Noise Output*—If a capnometer is included as a part or integral to other equipment, the relevant specification for that equipment shall apply.

26.2 If, when tested as described in 26.3, the A-weighted sound pressure level exceeds 60 dB, the circumstances under which it occurs shall be noted.

NOTE 5—If an attachment intended for a particular application reduces the A-weighted sound pressure level to 60 dB(A) or below, the manufacturer should state in which part or parts of the operating range this occurs.

26.3 The A-weighted sound pressure level shall be measured as follows:

26.3.1 *Measuring Instruments*—A precision sound level meter of Type 1, as specified in IEC Publication 651, shall be used. Measurements shall be made with the A-weighted network in use and the “slow” meter characteristics selected. The sound level meter shall be calibrated in accordance with the manufacturer’s instructions.

26.3.2 *Test Environment*—Measurement shall be made in a free field over a reflecting plane such as that specified in ISO 3744.

NOTE 6—The necessary conditions may be achieved economically on a hard, flat surface outdoors, in a large room, or in a smaller room with sufficient sound absorptive materials on its walls and ceiling.

26.3.3 *Ambient Conditions*—At the microphone positions, the A-weighted sound pressure levels of the background noise shall be at least 10 dB below the sound pressure level to be measured.

NOTE 7—If barometric pressure, temperature, or relative humidity deviate from those of standard conditions, appropriate corrections may be used.

26.3.4 *Capnometer Installation*—The capnometer shall be mounted as recommended by the instructions for use and in a manner typical of its intended use. If it is intended to be table-mounted, the table top shall be a hard acoustically reflecting surface unless a resilient pad is recommended in the installation instructions. If it is wall-mounted, the wall shall be of hard acoustically reflecting material.

26.3.5 *Procedure*—Operate the capnometer over its normal working range. Place the microphone at the position of maximum sound pressure level in the horizontal plane passing through the geometric center of the capnometer and at a radius of 1 m. At each setting, if the capnometer is intended for use with a sampling tubing, make a second measurement using the recommended sampling tubing. Place the sampling tubing inlet so as to lie on the specified horizontal plane, with the axis of the sampling tubing vertical and 150 mm from the microphone. If the length of the sampling tubing does not allow this disposition, move the microphone toward the capnometer until the distance between it and the sampling tubing is 150 mm. If the manufacturer recommends or supplies attachments for particular diagnostic applications and states that these reduce the A-weighted sound pressure level to 60 dB or less, repeat the measurements with the attachments fitted. If any such attachment incorporates a port intended for connection to an endotracheal or tracheostomy tube, connect a tube of an internal diameter equal to or greater than that of the port and at a length such that its other end will be sufficiently distant from the sound level meter not to interfere with the noise measurements.

36. *Electromagnetic Compatibility*—The requirements in Clause 36 of the General Standard apply with the following addition (the test method in 36.1 is derived from IEC 801-2:1991):

36.1 Protection from electrostatic discharge.

43.4.1 *Principle*—The oxygen level in the enclosed compartment is measured after the capnometer had been operated for 18 h under single fault conditions.

43.4.2 *Procedure*—Place the capnometer in a room in which the air exchange is between 3 and 10 room volumes per hour. Set the oxygen flow through the capnometer so that it equals the maximum flows of oxygen and nitrous oxide under normal conditions. Switch off the mains supply, and measure the oxygen level in the enclosed compartment. Operate the capnometer under single fault conditions with the least favorable control setting selected and with the mains voltage deviating by $\pm 10\%$, if applicable. After 18 h, switch off the supply mains and measure the oxygen level in the enclosed compartment.

43.4.3 *Expression of Results*—Record the oxygen levels measured at the beginning and end of the 18 h period.

43.5 Electrical circuits which can produce sparks or generate increased surface temperatures, and which can be a source of ignition, shall be so designed that no ignition occurs. At least the following requirements shall be satisfied in normal and single fault condition:

(1) The surface temperature of components shall not exceed 300°C.

NOTE 8—If it can be shown that the component burns when subjected to overheating in 100 % oxygen but without propagating the fire, this component may have a surface temperature that exceeds 300°C.

(2) Short- and open-circuiting of resistors, capacitors, and inductances complying with the requirements given in Clause 14 of IEC 65:1985 are not considered to be single fault conditions.

(3) Compliance shall be checked by the test given in 43.6.

43.6 Measure or calculate the voltages and currents in steady state conditions and measure the surface temperatures in normal condition and single fault condition.

44. *Overflow, Spillage, Leakage, Humidity, Ingress of Liquids, Cleaning, Sterilization and Disinfection*—The requirements given in Clause 44 of the General Standard apply, with the following additions:

44.8 *Condensation Effects*—The manufacturer shall disclose in the accompanying documents the effects of the test listed in 66.2.5 on the performance of the capnometer other than accuracy.

44.9 *Obstruction of the Sensing Area or Sampling Tubing*:

(1) The capnometer shall have a means of indicating obstruction of the sensing area or sampling tubing.

(2) Compliance shall be checked by the test given in 44.10.

44.10 *Test Method*—Totally obstruct the sensing area or sampling tubing at the sampling site, and verify that the requirements of 44.11 are met.

44.11 *Contamination of Breathing Systems*—It shall not be possible to reverse the direction of flow through the sampling tube in order to purge the capnometer.

46. *Human Errors*—Clause 46 of the General Standard applies with the following addition:

46.1 Gas connections provided for calibration gases shall not be interchangeable with DISS or pin index systems, and cylinders shall be color-coded differently from the colors used for medical gases.

50. *Accuracy of Operating Data*—Replace Clause 50 of the General Standard with the following:

50.1 *Measurement Accuracy*:

(1) The carbon dioxide reading shall be within $\pm 12\%$ of the actual test gas value or ± 4 mm Hg (0.53 kPa), whichever is greater, over the full range of the capnometer, corrected to one atmosphere (760 mm Hg).

(2) Compliance shall be checked by the test given in 50.2.

50.2 *Test Method*:

50.2.1 *Principle*—Carbon dioxide readings are determined at a number of carbon dioxide levels spanning the capnometer measurement range.

50.2.2 Test gases of an accuracy of 0.03 % as determined by gravimetric methods shall be used for these tests.

50.2.3 *Procedure*—The capnometer shall be set up in accordance with the accompanying documents and tested using

the test gas mixtures as described in 50.2.4 and 50.2.5.

50.2.4 *Dry Gas Testing*—Conduct the tests using the mixtures and conditions given in Table 1.

50.2.5 *Saturated Gas Testing*—After 24 h of continuous operation with the capnometer connected to a simulated breathing system containing air fully saturated with water at 37°C, and cycling at a frequency of 10 breaths/min between a pressure of ambient and 35 cm H₂O (3.5 kPa), perform an accuracy test using the mixtures and conditions given in Table 2.

50.3 *Stability of Measurement Accuracy*:

(1) The capnometer shall meet the requirements specified in 50.1 for no less than 24 h when used in accordance with the accompanying documents.

(2) Compliance shall be checked by the test given in 50.4.

50.4 *Test Method*—Repeat the tests given in 50.2 at the end of 24 h.

50.5 *Rise Time*—The manufacturer shall disclose in the accompanying documents the rise time for a 10 to 90 % step change in concentration, when tested as described in 50.6 (both increase and decrease in concentration), and shall also disclose the flow required to meet the disclosed rise time.

50.6 *Test Method*:

(1) The capnometer shall be set up in accordance with the accompanying documents and arranged as in Fig. 3. Connect the carbon dioxide signal output of the capnometer to a suitable recording device with a resolution within 1 %, reproducibility within 1 %, and a time constant equal to or less than one-tenth of the expected rise time of the capnometer.

(2) Pass dry air at ambient temperature and at a flow of 10 L/min through the test apparatus and the capnometer with the capnometer switched to normal function. By means of the three-way tap, a dry calibrated gas at ambient temperature containing approximately 5 % (V/V) of carbon dioxide is passed through the apparatus and the rise time is calculated. Repeat the above procedure, switching from 5 % (V/V) carbon dioxide to air.

50.7 *Procedure*—Hold the ambient temperature of the capnometer constant to within $\pm 2^\circ\text{C}$ of a nominal value within the operating range specified in the accompanying documents. Generate at least four stable carbon dioxide readings that span the range of the alarm system in approximately equal steps by varying the carbon dioxide level delivered to the sensor, or by electrically stimulating the sensor, or by adjusting the calibration control.

50.8 *Displays*—Carbon dioxide (CO₂) level displays shall be marked with kPa, V/V %, or mm Hg. Units of measure shall be marked by (adjacent to) the display, or be displayed on demand.

NOTE 9—Displays should not be obscured by the hand normally

TABLE 1 Dry Gas Testing

Composition	Range in Percent	Temperature	Humidity
Mixture No. 1	Carbon Dioxide: ^A 0 %, 2.5, 5.0, and 10.0, balance nitrogen	23 \pm 2°C	dry
Mixture No. 2	Carbon Dioxide: 0 %, 2.5, 5.0, and 10.0, balance air	23 \pm 2°C	dry

^A Carbon dioxide shall be expressed at one atmosphere, 23°C, as dry gas.

TABLE 2 Gas Testing Following Use in a Simulated Breathing System

Composition	Range in Percent	Temperature	Humidity
Mixture No. 1	Carbon Dioxide: ^A 0 %, 2.5, 5.0, and 10.0, balance nitrogen	37 ± 2°C	100 %
Mixture No. 2	Carbon Dioxide: 0 %, 2.5, 5.0, and 10.0, balance air	37 ± 2°C	100 %

^A Carbon dioxide shall be expressed at ambient pressure, 37°C, saturated with water vapor.

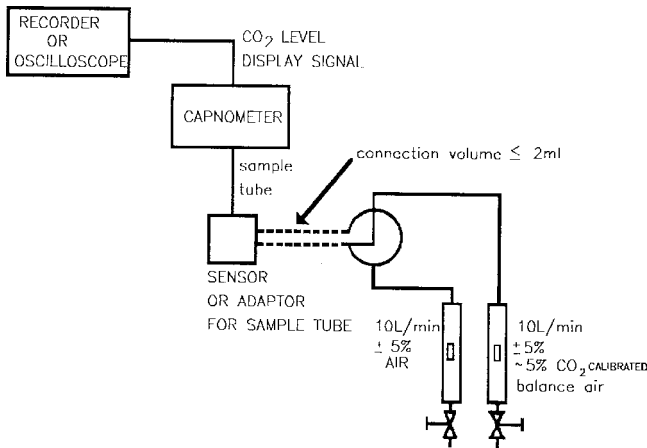

FIG. 3 Test Apparatus to Determine Response Time

adjusting the control(s) associated with the display.

51. *Protection Against Hazardous Output*—The requirements given in Clause 51 of the General Standard are replaced by the following:

51.1 *Control Function and Position:*

(1) If the intended test control function is not clearly distinguishable when displayed on the capnometer, the corresponding control(s) shall automatically return from such control function position(s). The positions of measurement and test controls shall be clearly distinguishable.

(2) Calibration controls shall include a means to prevent inadvertent change from the intended position.

NOTE 10—User-operable function checks other than “power on” for test controls, such as battery condition or signal operation, should automatically return from the check, test, or override position.

NOTE 11—All other controls should also include means to prevent inadvertent changes from the intended position and should have clearly distinguishable positions.

51.2 *Movement of Controls:*

(1) For controls that consist of a movable part and a non-movable part, movement upwards, to the right, or in a clockwise direction shall increase the control function. Movement downwards, to the left, or in an anti-clockwise direction shall decrease the control function.

(2) Rotary gas flow controls are exempt from this requirement.

NOTE 12—The separation between control knobs, switches, toggles, pinwheels, or push buttons should conform to the recommendations given in ISO 7249 and ISO 7250.

NOTE 13—Controls and their associated markings should be visible or legible, or both, to a user having a visual acuity (corrected, if necessary)

of at least 1.0 when the user is located at least 1 m in front of the capnometer and the illuminance level is 215 lx. Markings should be identified clearly with their associated controls.

51.3 *Alarms:*

51.3.1 *Alarm Prioritization*—The alarm characteristics of monitors specified in this specification shall be grouped in three categories: high priority, medium priority, and low priority (see Table 3).

51.3.1.1 The audible components of these alarms should be designed to allow silencing until the capnometer is placed in use (that is, connected to the patient) in order to reduce nuisance alarms.

51.3.1.2 There shall be a visual indication that an audible alarm has been silenced.

51.3.1.3 The set points of adjustable alarms shall be indicated continuously or on user demand.

51.3.2 *High Priority Alarms:*

51.3.2.1 There shall be a visual indication of the high priority alarm. It shall be different and distinguishable from the visual signals specified in 51.3.3 and 51.3.4.

51.3.2.2 There shall be a simultaneous audible indication of the high priority alarm. This audible indication shall be different and distinguishable from the audible signals specified in 51.3.3 and 51.3.4.

51.3.2.3 The audible indicators shall reset automatically when the condition causing the alarm has cleared.

51.3.3 *Medium Priority: Alarms*

51.3.3.1 There shall be a visual indication of the medium priority alarm. It shall be different and distinguishable from the visual signals specified in 51.3.2 and 51.3.4.

51.3.3.2 There shall be a simultaneous audible indication of the medium priority alarm. This audible indication shall be different and distinguishable from the audible signals specified in 51.3.2 and 51.3.4.

51.3.3.3 The audible indicator shall reset automatically when the condition causing the alarm has cleared.

51.3.4 *Low Priority Alarms:*

51.3.4.1 There shall be a visual indication of the low priority alarm. It shall be different and distinguishable from the visual signals specified in 51.3.2 and 51.3.3.

51.3.4.2 There may be a simultaneous audible indication of the low priority alarm. This audible indication, if provided, shall be a low priority alarm. This audible indication shall be different and distinguishable from the audible signals specified in 51.3.2 and 51.3.3.

51.3.4.3 The audible indicator shall reset automatically when the condition causing the alarm has cleared.

51.4 *Alarm Characteristics:*

51.4.1 The capnometer shall have a high carbon dioxide

TABLE 3 Alarms

Alarm Category	Operator Response	Audible Indicators ^A	Indicator Color ^B	Flashing Frequency (Hz) ^C
High priority	immediate	not medium or low priority I	red	1.4 to 2.8 Hz (F ₂)
Medium priority	prompt	not high or low priority	yellow	0.4 to 0.8 Hz (F ₁)
Low priority	awareness	not high or medium priority	yellow	constant (on)

reading alarm for both inspired and exhaled carbon dioxide.

51.4.2 The capnometer should have a low carbon dioxide reading alarm for exhaled carbon dioxide.

51.4.3 Alarm set points for both high and (if provided) low carbon dioxide reading alarms shall be operator-adjustable.

51.4.4 When the capnometer is switched on, the high carbon dioxide reading alarms for carbon dioxide shall be a medium priority alarm.

51.4.5 If a low carbon dioxide reading alarm is provided, it shall be a medium priority alarm.

51.4.6 If the capnometer has an operator-adjustable high carbon dioxide reading alarm priority control, it shall allow the operator to change the alarm priority between medium and high priority only after the capnometer is switched on.

51.4.7 If the capnometer has an automatic change in alarm priority setting, it shall change only to a higher alarm priority, and only after activation of the alarm.

(I) Compliance shall be checked by inspection.

51.4.8 The difference between the alarm set point and the carbon dioxide reading when the alarm is activated shall not exceed 0.2 volumes percent (1.4 mm Hg at 760 mm Hg barometric pressure, BTPS) carbon dioxide.

(I) Compliance shall be checked by the procedure given in 51.4.9.

51.4.9 Generate at least four stable carbon dioxide readings that span the range of the alarm system in approximately equal steps by varying the carbon dioxide level delivered to the sensor, or by electrically stimulating the sensor, or by adjusting the calibration control (if provided).

(I) For each carbon dioxide reading, adjust the alarm set point so that the alarm is deactivated. Incrementally adjust the alarm set point until the alarm is activated, and record the carbon dioxide reading at which the alarm is activated. The difference between the alarm set point and the corresponding carbon dioxide reading shall not exceed 0.2 volumes percent.

51.5 *Announcement of Alarm Condition:*

51.5.1 If alarm set points are adjustable by the operator, operator adjustment of alarm set points or default parameters shall require a deliberate sequence of actions on the part of the operator.

(I) Temporary silencing of audible alarms, if provided, shall not exceed 2 min. The visual signals shall remain until the alarming condition no longer exists. If permanent silencing of the audible portion is provided, it shall require deliberate action on the part of the operator. The visual indication shall remain until the alarming condition no longer exists.

51.5.2 All alarms shall be provided with a default setting, and that default setting shall be disclosed in the accompanying documents.

6. Additional Requirements Specifically Related to Capnometers

60. *Interfering Gas and Vapor Effects (Other Than Water Vapor):*

60.1 The manufacturer shall disclose in the accompanying documents any adverse interference caused by the gases and vapors at the concentrations listed in Table 4.

60.2 Compliance shall be tested as follows:

60.2.1 *Principle*—The accuracy of the carbon dioxide read-

TABLE 4 Test Concentrations of Interfering Gases or Vapor

Gas or Vapor	Concentration (vol %)
Oxygen	100
Nitrous oxide	80
Halothane	4
Enflurane	5
Isoflurane	5
Ethanol	specified by manufacturer
Acetone	specified by manufacturer
Chlorodifluoromethane	5

ing is determined in the presence of the interfering gases and vapors given in Table 4.

60.2.2 *Test Gases*—Test gases shall be dry pre-mixtures of 5 % carbon dioxide (nominal), balance nitrogen, and the interfering gas or vapor at the level given in Table 4. Carbon dioxide levels shall be known to within $\pm 2\%$ (V/V) of the specified value used.

60.2.3 *Procedure*—Calibrate the capnometer according to the instructions for use, and then expose the sensor to the test gas for a continuous period of 2 h, ensuring that both the capnometer and the sensor are maintained in the same condition during the whole period. Repeat the procedure for each application mixture in Table 4.

60.2.4 *Expression of Results*—Correct the carbon dioxide readings for changes in barometric pressure, if the errors due to this effect equal or exceed $_0.1\%$ (V/V) carbon dioxide, and report the corrected readings.

61. *Sustained Pressure:*

61.1 Capnometers shall either:

(1) Meet the requirements given in 50.3 and 50.7 following exposure to a sustained positive pressure of 10 kPa (100 cm H₂O) and a negative pressure of 1.5 kPa (15 cm H₂O) for 30 s; or

(2) Be marked with the warning “not for use in breathing systems,” and a similar warning shall appear in the accompanying documents.

(3) Compliance with (1) shall be checked by the test given in 61.2.

61.2 Compliance shall be tested as follows:

61.2.1 *Principle*—The accuracy of the carbon dioxide reading and the rise time are determined after exposure of the sensor to sustained pressure.

61.2.2 *Procedure*—Expose the sampling site to a sustained positive pressure with respect to ambient of 10 ± 1 kPa (100 \pm 10 cm H₂O) and a sustained negative pressure with respect to ambient of 1.5 ± 0.2 kPa (15 \pm 2 cm H₂O), in turn, for not less than 30 s each. Repeat this procedure four times, and then conduct the test for measurement accuracy as described in Clause 50.2 and the test for rise time as described in Clause 50.6.

62. *Gas Leakage and Sampling Loss:*

62.1 The rate of leakage for a non-diverting capnometer shall not be greater than 20 mL/min under the test conditions.

NOTE 14—The rate at which a sampling capnometer withdraws gas from a breathing system (the gas diversion rate) should not exceed 1.15 times the value stated in the accompanying documents.

NOTE 15—This requirement ensures that when fitted to a breathing system, the capnometer’s rate of leakage at a continuous pressure of 3.0 kPa (30 cm H₂O) does not exceed more than 20 mL/min.

(I) Compliance shall be checked by the test given in 62.2.

62.2 Compliance shall be tested as follows:

62.2.1 *Apparatus*—A pressure gage having an accuracy to within ± 0.3 kPa and a flow metering device having an accuracy within ± 2 mL/min shall be used.

62.2.2 *Procedure*—Tests shall be performed in both the ready for use and off configuration. Assemble the capnometer so that the sampling site is installed in a dimensionally suitable port of a test apparatus containing an inlet fitting to which a test gas and airflow metering device are attached. Connect the pressure gage to a third port of a test apparatus. Slowly adjust the flow to raise the pressure in the test apparatus to 3 kPa. Determine the flow necessary to maintain this pressure. This leakage flow shall be as specified in Clause 62.1.

62.3 The rate at which a sampling capnometer withdraws gas from a breathing system (the gas diversion rate) shall not exceed 1.15 times the value stated in the accompanying documents.

(I) Compliance shall be checked by the test given in 62.4.

62.4 *Method of Test*:

62.4.1 *Principle*—The rate at which a sampling capnometer withdraws gas from a simulated breathing system is measured.

62.4.2 *Test Gas*—Pressurized air at room temperature shall be used.

62.4.3 *Apparatus*—A pressure gage having an accuracy to within ± 0.3 kPa, and a flow or volume measurement device having an accuracy to within ± 2.5 % of the rate at which the capnometer withdraws gas from the breathing system as stated in the accompanying documents.

62.4.4 *Procedure*—Assemble the apparatus as described in 62.2.2 but using the flowmeter specified in 62.4.3. Adjust the pressurized air source to 3.0 kPa and monitor the flow reading for 1 min.

62.5 An exhaust port shall be provided to collect or route the diverting gas from the capnometer, and this exhaust port shall be incompatible with the inlet port of the capnometer.

(I) Compliance shall be checked by inspection.

63. *Breathing System Connections*—If a capnometer is intended to be connected to the breathing system through a T-piece, the breathing system connection ports of the T-piece shall be a 15 or 22 mm, or both, conical connector in accordance with Specification F 1054-88 (or ISO 5356/1:1987). The sampling gas and outlet ports of a diverting capnometer shall not be interchangeable with the breathing system connection port of a breathing system.

NOTE 16—Annexes A to M given in the General Standard, together with Appendix X1 in this draft specification, apply.

APPENDIX

(Nonmandatory Information)

X1. RATIONALE

X36.1 Capnometers are not life-support devices but are a “vigilance adjunct.” Therefore, it is acceptable if this device fails without creating a safety hazard (that is, without affecting patient safety directly) or presenting erroneous data. The test voltages of 8 kV for air discharges and 3 kV for contact discharges using the IEC 801-2:1991 network and procedures are adequate to ensure good performance under the conditions in which capnometers are used. It is necessary to limit the application of discharges to accessible parts, since to allow the application of charges to the interior of the device would impose unnecessary design restrictions. It is reasonable to require any person opening a device for maintenance to exercise both common sense and accepted work practices, which include ESD precautions.

X50.1 Accurate knowledge of inspired and exhaled carbon

dioxide concentration provides the clinician with information regarding the patient’s cardiopulmonary status, function of the airway, and integrity of the breathing circuit. Adjustments to pulmonary ventilation, blood volume, and systemic circulation are often based on values of exhaled carbon dioxide. Recognition of unintended esophageal intubation, partial and complete airway obstruction, and rebreathing of exhaled carbon dioxide from the breathing system are often first recognized by changes in the respired carbon dioxide concentrations. For clinicians to use capnometers routinely for enhancement of patient safety and management, there must be confidence in the reliability and accuracy of the displayed data from the capnometer. The accuracy requirements detailed in Clause 50 are sufficient to meet these safety concerns.

The American Society for Testing and Materials takes no position respecting the validity of any patent rights asserted in connection with any item mentioned in this standard. Users of this standard are expressly advised that determination of the validity of any such patent rights, and the risk of infringement of such rights, are entirely their own responsibility.

This standard is subject to revision at any time by the responsible technical committee and must be reviewed every five years and if not revised, either reapproved or withdrawn. Your comments are invited either for revision of this standard or for additional standards and should be addressed to ASTM Headquarters. Your comments will receive careful consideration at a meeting of the responsible technical committee, which you may attend. If you feel that your comments have not received a fair hearing you should make your views known to the ASTM Committee on Standards, 100 Barr Harbor Drive, West Conshohocken, PA 19428.

This standard is copyrighted by ASTM, 100 Barr Harbor Drive, West Conshohocken, PA 19428-2959, United States. Individual reprints (single or multiple copies) of this standard may be obtained by contacting ASTM at the above address or at 610-832-9585 (phone), 610-832-9555 (fax), or service@astm.org (e-mail); or through the ASTM website (<http://www.astm.org>).