**Ophthalmic instruments — Fundus
cameras**

*Instruments ophtalmiques — Appareils photographiques du fond de
l'œil*



PDF disclaimer

This PDF file may contain embedded typefaces. In accordance with Adobe's licensing policy, this file may be printed or viewed but shall not be edited unless the typefaces which are embedded are licensed to and installed on the computer performing the editing. In downloading this file, parties accept therein the responsibility of not infringing Adobe's licensing policy. The ISO Central Secretariat accepts no liability in this area.

Adobe is a trademark of Adobe Systems Incorporated.

Details of the software products used to create this PDF file can be found in the General Info relative to the file; the PDF-creation parameters were optimized for printing. Every care has been taken to ensure that the file is suitable for use by ISO member bodies. In the unlikely event that a problem relating to it is found, please inform the Central Secretariat at the address given below.



COPYRIGHT PROTECTED DOCUMENT

© ISO 2009

All rights reserved. Unless otherwise specified, no part of this publication may be reproduced or utilized in any form or by any means, electronic or mechanical, including photocopying and microfilm, without permission in writing from either ISO at the address below or ISO's member body in the country of the requester.

ISO copyright office
Case postale 56 • CH-1211 Geneva 20
Tel. + 41 22 749 01 11
Fax + 41 22 749 09 47
E-mail copyright@iso.org
Web www.iso.org

Published in Switzerland

Contents

Page

Foreword.....	iv
1 Scope	1
2 Normative references	1
3 Terms and definitions.....	1
4 Requirements	2
4.1 General.....	2
4.2 Optical properties	2
4.3 Construction and function.....	3
4.4 Optical radiation hazard with fundus cameras.....	3
5 Test methods for checking the optical properties	4
5.1 General.....	4
5.2 Test target arrangement.....	4
5.3 Checking the resolving power of the fundus camera optics	5
5.4 Checking the angular field of view.....	5
5.5 Checking the magnification of the image.....	5
5.6 Checking the pixel pitch of a sensor on the fundus	6
6 Accompanying documents.....	6
7 Marking	6
Annex A (normative) Guidance for the measurement and calculation of the light hazard related values	7
Annex B (informative) Guidance for safe use of the fundus camera	12

Foreword

ISO (the International Organization for Standardization) is a worldwide federation of national standards bodies (ISO member bodies). The work of preparing International Standards is normally carried out through ISO technical committees. Each member body interested in a subject for which a technical committee has been established has the right to be represented on that committee. International organizations, governmental and non-governmental, in liaison with ISO, also take part in the work. ISO collaborates closely with the International Electrotechnical Commission (IEC) on all matters of electrotechnical standardization.

International Standards are drafted in accordance with the rules given in the ISO/IEC Directives, Part 2.

The main task of technical committees is to prepare International Standards. Draft International Standards adopted by the technical committees are circulated to the member bodies for voting. Publication as an International Standard requires approval by at least 75 % of the member bodies casting a vote.

Attention is drawn to the possibility that some of the elements of this document may be the subject of patent rights. ISO shall not be held responsible for identifying any or all such patent rights.

ISO 10940 was prepared by Technical Committee ISO/TC 172, *Optics and photonics*, Subcommittee SC 7, *Ophthalmic optics and instruments*.

This second edition cancels and replaces the first edition (ISO 10940:1998) which has been technically revised.

Ophthalmic instruments — Fundus cameras

1 Scope

This International Standard, together with ISO 15004-1 and ISO 15004-2, specifies requirements and test methods for fundus cameras operating for observing, photographing or recording electronic images of the fundus of the human eye in order to provide the image information for diagnosis. This International Standard is not applicable to the following instruments:

- those that contact the eye during the examination;
- those using scanning laser sources.

This International Standard takes precedence over ISO 15004-1 and ISO 15004-2, if differences exist.

2 Normative references

The following referenced documents are indispensable for the application of this document. For dated references, only the edition cited applies. For undated references, the latest edition of the referenced document (including any amendments) applies.

ISO 15004-1, *Ophthalmic instruments — Fundamental requirements and test methods — Part 1: General requirements applicable to all ophthalmic instruments*

ISO 15004-2:2007, *Ophthalmic instruments — Fundamental requirements and test methods — Part 2: Light hazard protection*

IEC 60601-1:2005, *Medical electrical equipment — Part 1: General requirements for basic safety and essential performance*

3 Terms and definitions

For the purposes of this document, the following terms and definitions apply.

3.1

resolving power of the fundus camera optics on the fundus

minimum separation allowing recognition of two adjacent lines on the fundus, expressed as number of line pairs per millimetre (lp/mm)

3.2

angular field of view

FOV

maximum image size displayed on the image plane, expressed as the angle subtended at the exit pupil of the eye by the maximum dimension $2r$

See Figure 1.

3.3 magnification of image

ratio of the size of an object at the centre on the image plane to that of the fundus, assuming that the eye is emmetropic and that it has a focal length of 17 mm in air

3.4 pixel pitch on the fundus

distance between two pixels (from centre to centre) of a digital image sensor theoretically projected on to the fundus, expressed in micrometres (μm), assuming that the eye is emmetropic and that it has a focal length of 17 mm in air

3.5 high eye point eyepiece

eyepiece in which the exit pupil is of sufficient clearance from the eyepiece to allow spectacles to be worn

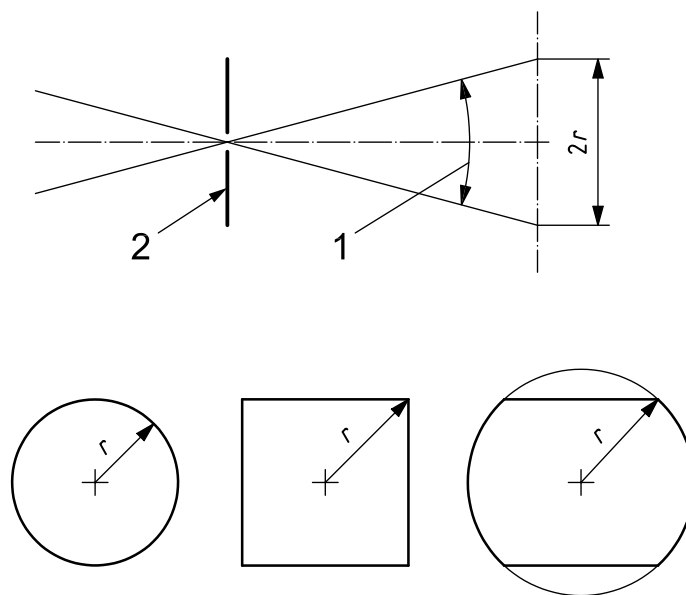

Key

- 1 angular field of view
- 2 entrance pupil of instrument/exit pupil of eye

Figure 1 — Meaning of dimension r for various formats

4 Requirements

4.1 General

The fundus camera shall conform to the requirements specified in ISO 15004-1 and ISO 15004-2.

4.2 Optical properties

The fundus camera shall conform to the requirements given in Table 1.

When using near infrared light (NIR) for imaging (e.g. ICG application), the given limits for resolving power shall be reduced by a factor of 1,6.

It is recommended that an oblique astigmatism compensator be provided for observation and recording images of the periphery of the retina when using a fundus camera with an optical angular field $\leq 30^\circ$.

Table 1 — Requirements for optical properties

Criterion		Requirement	
Resolving ^a power on the fundus for fundus camera optics	Field of view $\leq 30^\circ$	centre	≥ 80 lp/mm
		middle ($r/2$)	≥ 60 lp/mm
		periphery (r)	≥ 40 lp/mm
	Field of view $> 30^\circ$	centre	≥ 60 lp/mm
		middle ($r/2$)	≥ 40 lp/mm
		periphery (r)	≥ 25 lp/mm
Tolerance of angular field of view		$\pm 5\%$	
Tolerance of magnification of image ^b		$\pm 7\%$	
Tolerance of pixel pitch on fundus ^c		$\pm 7\%$	
Range of dioptr adjustment of the optical finder (when an optical finder is attached)		– 5 D to + 5 D	
		– 4 D to + 4 D for high eye point eyepieces	
Range of focus adjustment for compensation of patient's refractive error		– 15 D to + 15 D	
^a To achieve the resolving power according this table, optical means are recommended. In the case of recording images, it is necessary to choose an appropriate medium (film or digital sensor). ^b Only for fundus cameras recording on film. ^c Only for fundus cameras recording on a digital sensor.			

4.3 Construction and function

4.3.1 General

The instrument shall be designed in such a way that neither reflection nor stray light degrades the image.

4.3.2 High eye point eyepiece

If the manufacturer states that the eyepiece is a high eye point eyepiece, the clearance shall be ≥ 17 mm, as measured from that part of the eyepiece nearest the examiner's eye to the exit pupil of the instrument.

4.4 Optical radiation hazard with fundus cameras

This clause replaces 10.5, 10.6 and 10.7 of IEC 60601-1:2005. Fundus cameras shall comply with the light hazard protection requirements that are given in ISO 15004-2 in consideration of the following modality. (For guidance, see Annex A.)

It shall first be determined if the fundus camera is classified as a group 1 or group 2 instrument in accordance with ISO 15004-2:2007, Clause 4. The applicable clauses of ISO 15004-2:2007 for fundus cameras are as follows.

a) For group 1 fundus cameras:

- 1) applicable requirements of ISO 15004-2:2007 are 5.1, 5.2 and 5.4 (except 5.4.3). For cameras with multiple sources designed to direct optical radiation on to the same point(s) of the eye at the same time, the following shall apply:
 - i) the optical radiation emissions shall be below all applicable limits for each light source alone;
 - ii) the resulting or combined radiation of the multiple sources shall be below all applicable limits of ISO 15004-2:2007, Table 2 or Table 3;

- 2) applicable test methods are given in ISO 15004-2:2007, 6.1, 6.2 and 6.4.

If status is determined to be group 1, there are no further requirements. If status is determined not to be group 1, the additional requirements given in b) are applicable.

b) For group 2 fundus cameras:

- 1) applicable requirements of ISO 15004-2:2007 are 5.1, 5.3, 5.5 (except 5.5.3). For cameras with multiple sources designed to direct optical radiation on to the same point(s) of the eye at the same time the following shall apply:
 - i) the optical radiation emissions shall be below all applicable limits for each light source alone;
 - ii) the resulting or combined radiation of the multiple sources shall be below all applicable limits or guideline values of ISO 15004-2:2007, Tables 4, 5 and 6;
 - iii) for intended consecutive and/or simultaneous use of pulsed and continuous light sources within an 8 h period, the sum of the ratios of the optical radiation emitted over the specified wavelength range according ISO 15004-2:2007, Tables 4, 5 and 6 to the applicable limit or guideline value shall be less than one. Only ratios of the same kind, i.e. related to the same hazard (e.g. photochemical, thermal or aphakic), shall be considered;
- 2) applicable test methods are given in ISO 15004-2:2007, 6.1, 6.2, 6.3, 6.4 and 6.5;
- 3) ISO 15004-2:2007, Clause 7.

If a fundus camera is capable of emitting more radiation in the visible or infrared wavelength range than specified for group 2 instruments, the manufacturer shall inform the user in the user manual about the potential hazard. See Annex B.

5 Test methods for checking the optical properties

5.1 General

All tests described in this International Standard are type tests.

The requirements specified in 4.2 shall be verified by use of measuring devices, the measuring errors of which are less than 10 % of the smallest value to be determined.

5.2 Test target arrangement

5.2.1 Test target distance

The resolving power, the angular field of view, the magnification of image and the pixel pitch shall be checked using a test target in front of the fundus camera. The test target shall be used at a distance of 1 m from the entrance pupil of the fundus camera. The distance of 1 m shall be determined with a tolerance of ≤ 5 mm.

5.2.2 Test target illumination

The light source used to illuminate the test target may be the normal fundus camera light source or may be an external white light source. In either case, the light shall be filtered by a band-pass filter with peak transmission wavelength between 520 nm and 560 nm and a half-peak bandwidth of less than 80 nm. For NIR applications, the peak transmission wavelength shall be between 790 nm and 890 nm with a half-peak width of less than 120 nm.

5.2.3 Test target design

The test target for resolving power shall be in accordance with Figure 2, which has black lines on a white ground. The black lines shall be equal in width to the white ground between them. The length of the lines shall be $5 \times$ greater than their width and the reflectivity of the white ground shall be $1,4 \times$ (or more) that of the reflectivity of the black lines. The targets shall consist of two sets of three lines each. The lines in a set shall be parallel to one another. The lines of one set shall be perpendicular to the lines of the other set (see Figure 2). In the central target, the sets shall be oriented horizontally and vertically. In the peripheral target, the sets shall be oriented radially and tangentially.



Figure 2 — Test target for checking the resolving power

5.3 Checking the resolving power of the fundus camera optics

The test target images from the centre, middle and periphery used for checking resolving power as specified in Table 1 for the three areas shall all be contained in the same image.

The limits specified in Table 1 are requirements for the optical performance of the fundus camera without a dedicated sensor (film or CCD), since this standard is not a standard for image sensors. Attention is to be paid to the fact that the resolving power of the medium used is not the limit for verification. It is recommended that visual means be used to check the resolving power in the image plane. If this is not possible, a sensor or film with appropriate resolution capability shall be chosen.

NOTE The resolving power on the fundus is given by using the factor 0,017 for an eye with a focal length of 17 mm.

5.4 Checking the angular field of view

The angular field of view shall be checked by taking an image of a graduated target (e.g. a scale, rule, measuring tape) placed 1 m from the entrance pupil of the fundus camera. The scale shall be perpendicular to the optical axis and centred to the field of view in accordance with Figure 1. Determine the distance $2r$, in millimetres, from edge to edge on the image of the visible scale. The angular field of view is found then by using Equation (1):

$$\text{FOV} = 2 \cdot \arctan (r/1\ 000) \quad (1)$$

All distances shall be determined with a tolerance of ≤ 5 mm.

5.5 Checking the magnification of the image

The magnification of the image shall be checked by imaging a 100 mm graduated target scale held on a screen 1 m from the entrance pupil of the fundus camera. The length of the image of the scale, L , in the resulting image shall be measured. L shall be expressed in millimetres. The magnification of image M is then found by using Equation (2):

$$M = L/1,7 \quad (2)$$

NOTE The value 1,7 results from the assumption that the eye is emmetropic and has a focal length of 17 mm.

5.6 Checking the pixel pitch of a sensor on the fundus

The pixel pitch of a sensor on the fundus shall be checked by taking an image of a 100 mm graduated target scale held on a screen 1 m from the entrance pupil of the fundus camera. The number of pixels covering the scale, N , in the resulting digital image shall be determined, e.g. by using image processing software. The pixel pitch in micrometres is then found by using Equation (3):

$$P = 1\,700/N \quad (3)$$

NOTE 1 The pixel pitch on the fundus camera may be calculated by using the formula $P = P_s/M$, where P_s is the real pixel pitch provided by the vendor of the sensor and M is the magnification of the images determined by 5.5.

NOTE 2 The value 1 700 results from the assumption that the eye is emmetropic and has a focal length of 17 mm.

6 Accompanying documents

The fundus camera shall be accompanied by documents containing instructions for use. In particular, these shall contain:

- a) name and address of the manufacturer;
- b) if appropriate, a statement that the fundus camera in its original packaging conforms to the transport conditions as specified in ISO 15004-1;
- c) any additional documents as specified in 7.9 of IEC 60601-1:2005;
- d) a reference to this International Standard, i.e. ISO 10940:2009, if the manufacturer or supplier claims compliance with it;
- e) if requested, information about the resolving power of the fundus camera system (with the supplied sensor);
- f) information about possible artefacts in the image caused by construction of the device;
- g) information about magnification of the image (record on film) or the pixel pitch on fundus (digital sensor) for an emmetropic eye with a 17 mm focal length;
- h) information about potential optical radiation hazards, in case the instrument is capable of emitting optical radiation more than the levels determined in ISO 15004-2:2007, 5.5.1.3, 5.5.1.4, 5.5.1.5, 5.5.2.1, 5.5.2.2 and 5.5.2.3.

7 Marking

The fundus camera shall be permanently marked with at least the following information:

- a) name and address of the manufacturer or supplier;
- b) name and model of the fundus camera;
- c) marking as required by IEC 60601-1.

Annex A (normative)

Guidance for the measurement and calculation of the light hazard related values

All considerations shall be done according to the principle of a risk analysis. The measurement shall meet the worst case conditions regarding intensity, field angle and spectral band width. If a worst case condition is below the limits, it is not necessary to check further operation modes with decreased spectral bands or reduced light intensity conditions.

It is not required to check each single operation mode of the fundus camera. If available, designed values or certified specifications may be used instead of measurements.

Most fundus cameras have a so-called Maxwellian view illumination in order to illuminate the retina uniformly. The light source image, which is designed usually as a ring or a rectangle shape, is located inside of the pupil when the device is correctly aligned toward the subject's eye. If Maxwellian view illumination does not apply, see Annex D and E of ISO 15004-2:2007 for guidance on measurements of irradiance.

The examination facilitates the following method of determining the required parameters. See the flowchart in Figure A.1.

Explanation of the procedure.

- 1) Measurement or calculation of the illuminated area in the plane (in air) where the cornea is placed under properly aligned conditions, centre positioned. In the majority of cases this is a ring-shaped area.
- 2) Measurement or calculation of the illuminated area, A , on the retina. In the majority of cases this is a homogeneously illuminated spherical calotte of the eyeball. If the solid angle, ω , of the illumination is known, the area can be calculated by Equation (A.1):

$$A = (1,7 \text{ cm})^2 \times \omega \quad (\text{A.1})$$

If the solid angle is not known but the full cone angle, α , of the illumination is known, the solid angle can be calculated by Equation (A.2):

$$\omega = 4\pi \sin^2 (\alpha/4) \quad (\text{A.2})$$

The full cone angle can be measured on a plane in a known distance, l , after the position of the beam waist in air by determining the radius x of the illumination field. Then, using Equation (A.3), α is found to be:

$$\alpha = 2 \arctan (x/l) \quad (\text{A.3})$$

See Figure A.2.

- 3) Determination of the flash pulse time (if applicable); this is required for calculation of different limits for pulsed instruments.
- 4) Measurement of the irradiance, E , or exposure, H , against wavelength at the corneal plane (see ISO 15004-2:2007, D.2) within the spectral range 250 nm to 2 500 nm [or less if spectral bands are blocked by filters, etc., see ISO 15004-2:2007, 5.2 b)]. It is not necessary to measure the spectral distribution if no weighting function applies for the spectral band at all or the summed data are already below the weighted limits and the weighting factors within the related spectral band are below 1,0.

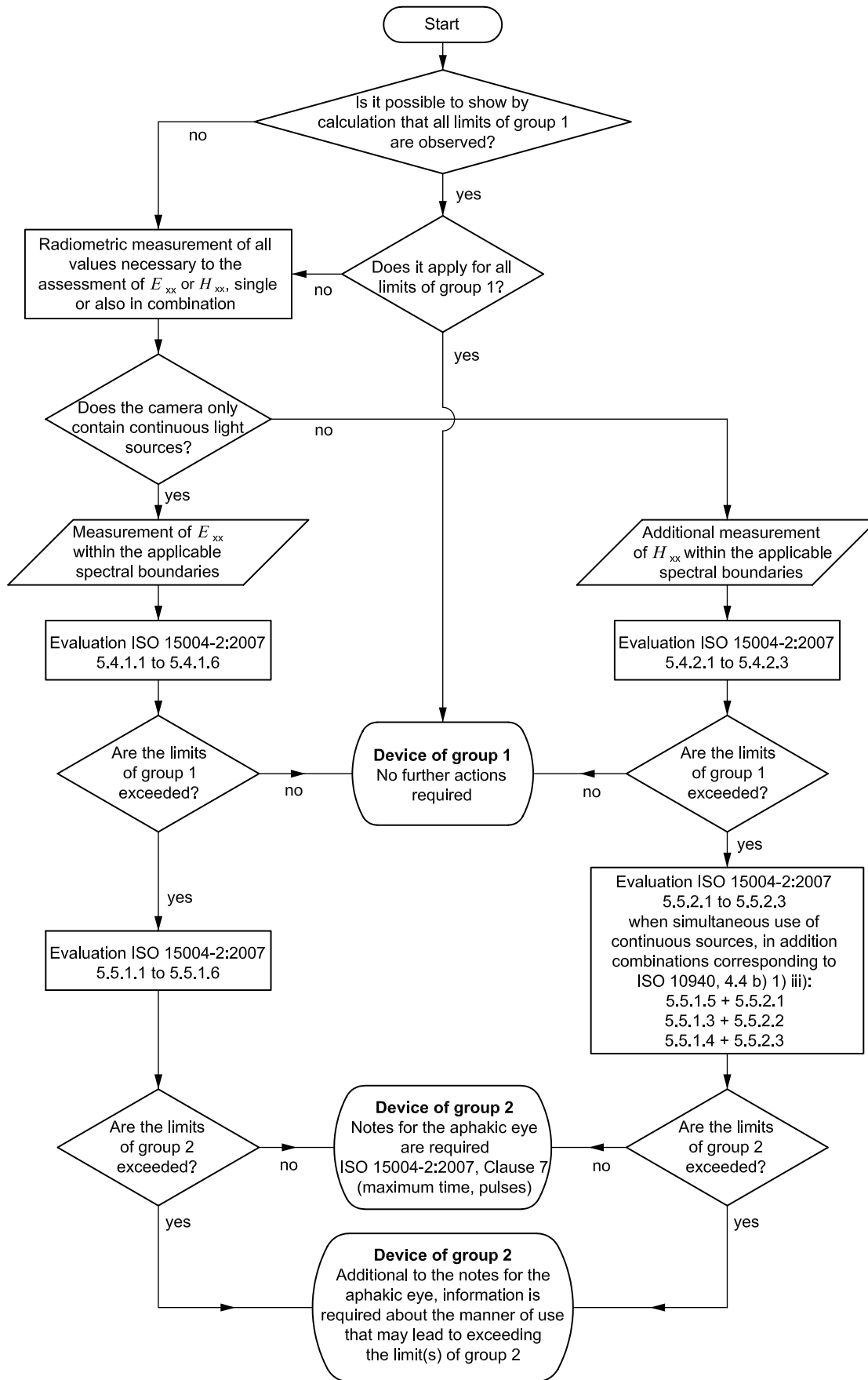
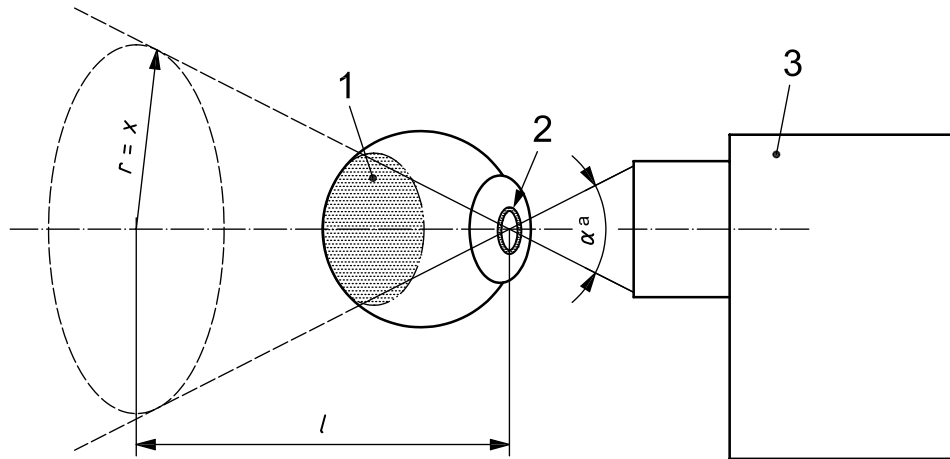

Figure A.1 — Flowchart of the procedure

**Key**

- 1 illumination area A on retina
- 2 light source image
- 3 fundus camera

^a α is the full cone angle.

NOTE 1 Measurement taken without the eye in the plane of the light source in air.

NOTE 2 When the alignment of the device is correctly done, the light source image of the fundus illumination is located on the inside of the pupil. The light source image illuminates the fundus uniformly covering more than the official angular field of view of the fundus camera.

Figure A.2 — Maxwellian view illumination conditions on the eye

- 5) Calculate all related values of E_{xx} by using the weighting functions $S(\lambda)$, $A(\lambda)$ and $R(\lambda)$ and sum over the specific spectral bands. Retinal related values shall be obtained by dividing the radiant power entering the eye within a centred 7 mm aperture by the area illuminated on the retina. Corneal and anterior segment related values shall be obtained by dividing the radiant power entering the eye by the area illuminated at the cornea plane.
- 6) Exposure values H_{xx} for continuous wave instruments are based on irradiance and 7 200 s.
- 7) For pulsed operation modes, both single and multiple pulses (if applicable) are to be considered within a time period of 20 s. In case of repetitively pulsed lasers, a correction factor of $N^{-1/4}$ applies for checkpoint 5.5.2.1 of ISO 15004-2:2007 (N is the number of pulses, see Note 2 of Table 6 of ISO 15004-2:2007).
- 8) For the intended consecutive and/or simultaneous use of the pulsed and continuous light sources within an 8 h period, the sum of the ratios of the optical radiation emitted over the specified wavelength range according to Tables 4, 5 and 6 of ISO 15004-2:2007 to the applicable limit or guideline value shall be less than one. Only ratios of the same kind (related to the same hazard, e.g. photochemical, thermal or aphakic) are to be considered.

EXAMPLE

A Fundus camera with a halogen bulb for continuous illumination and a flash light source for photography is to be evaluated. The ring pupil at the cornea plane has been measured with an area of 0,2 cm². The full cone angle for the illumination system is known to be 46°. The related solid angle, $\omega = 4\pi \sin^2(46^\circ/4) = 0,5$. The illumination area on the retina is calculated to be $A = (1,7 \text{ cm})^2 \times 0,5 = 1,44 \text{ cm}^2$. The pulse time for the maximum flash level is 0,01 s. A certified UV and IR blocking filter is implemented, thus no radiation below 400 nm and over 1 200 nm is emitted. The worst case scenario is the “colour mode” with the largest spectral bandwidth. The measurement findings at maximum operation levels and worst case conditions in the “colour mode” related to ISO 15004-2 are:

For continuous illumination (halogen lamp) and group 1 instruments:

Subclause of ISO 15004-2:2007	Description	Result	Comment
5.4.1.1	$S(\lambda)$ weighted UV irradiance E_{S-CL} , (250 nm – 400 nm):	—	no measurement required (blocking filter)
5.4.1.2	unweighted UV irradiance E_{UV-CL} , (360 nm – 400 nm):	—	no measurement required (blocking filter)
5.4.1.3	$A(\lambda)$ weighted irradiance E_{A-R} , (305 nm – 700 nm):	1 300 $\mu\text{W}/\text{cm}^2$	More than the group 1 limit of 220 $\mu\text{W}/\text{cm}^2$. However, for group 2 is calculated: 1 300 $\mu\text{W}/\text{cm}^2 \times 7\ 200 \text{ s} = 9,36 \text{ J}/\text{cm}^2$. This result is below the guideline of 10 J/cm^2 for group 2.
5.4.1.4	unweighted IR irradiance E_{IR-CL} , (770 nm – 2 500 nm):	9,2 mW/cm^2	below the limit
5.4.1.5	unweighted convergent irradiance E_{VIR-AS} , (380 nm – 1 200 nm):	0,15 W/cm^2	below the limit
5.4.1.6	$R(\lambda)$ weighted thermal irradiance E_{VIR-R} , (380 nm – 1 400 nm):	0,014 W/cm^2	below the limit

For pulsed illumination (flash light), $t = 0,01\text{s}$:

Subclause of ISO 15004-2:2007	Description	Result	Comment
5.4.2.1	$R(\lambda)$ weighted radiant exposure H_{VIR-R} , (380 nm – 1 400 nm):	single pulse is 0,05 J/cm^2	The value is below the calculated limit of 0,19 J/cm^2 (for single pulse time of 10 ms). The camera is capable of emitting 10 pulses repetitively within 20 s. The limit for 10 pulses is 1,06 J/cm^2 . The resulting exposure is 0,50 J/cm^2 and below the limit.
5.4.2.2	unweighted IR radiant exposure H_{IR-CL} , (770 nm – 2 500 nm):	single pulse is 0,006 J/cm^2	The value is below the limit of 0,57 J/cm^2 (single pulse). The limit for 10 pulses is 1,01 J/cm^2 . The resulting exposure for 10 pulses is 0,06 J/cm^2 and below the limit.
5.4.2.3	unweighted convergent exposure H_{VIR-AS} , (380 nm – 1 200 nm):	single pulse is 0,41 J/cm^2	The value is below the limit of 7,91 J/cm^2 (single pulse). The resulting exposure for 10 pulses is 4,1 J/cm^2 and the limit for 10 pulses is 14,0 J/cm^2 .

For multiple sources:

The light source emissions are below the applicable limits for each source alone. For the intended consecutive and/or simultaneous use of the pulsed and continuous light sources within an 8 h period, the sum of the ratios of the optical radiation emitted over the specified wavelength range to the applicable limit or guideline value shall be less than one. Only ratios of the same kind are to be considered. The intended use for the application is, for example, a 10 min examination with illumination light and taking five photos at maximum flash level for each eye. The following ratios are applicable for a group 2 camera:

$$5.5.1.5 \text{ and } 5.5.2.1: \quad (0,014 \text{ W/cm}^2/0,7 \text{ W/cm}^2) + (0,25 \text{ J/cm}^2/0,62 \text{ J/cm}^2) = 0,42 \text{ (less than 1)}$$

$$5.5.1.3 \text{ and } 5.5.2.2: \quad (9,2 \text{ mW/cm}^2/100 \text{ mW/cm}^2) + (0,03 \text{ J/cm}^2/0,85 \text{ J/cm}^2) = 0,13 \text{ (less than 1)}$$

$$5.5.1.4 \text{ and } 5.5.2.3: \quad (0,15 \text{ W/cm}^2/20 \text{ W/cm}^2) + (2,05 \text{ J/cm}^2/11,87 \text{ J/cm}^2) = 0,18 \text{ (less than 1)}$$

Conclusion:

The fundus camera meets all limits of group 1 instruments except checkpoint 5.4.1.3 of ISO 15004-2:2007. Therefore, the fundus camera is defined as a group 2 instrument and additional information for aphakic hazard is to be provided regarding ISO 15004-2:2007, 6.5.

The determination of the maximum time to reach the guideline value for aphakic retinal exposure is as follows:

$$t_{\max}(E_{A-R}) = 10 \text{ J/cm}^2/1 \text{ 300 } \mu\text{W/cm}^2 = 7 \text{ 692 s}$$

For determination of the maximum number of pulses to reach the guideline value for aphakic exposure, H_{A-R} , the flash light source was measured to $0,007 \text{ 8 J/cm}^2$. Thus, the maximum number of pulses is:

$$n_{\max}(H_{A-R}) = 10 \text{ J/cm}^2/0,007 \text{ 8 J/cm}^2 = 1 \text{ 282}$$

No other calculated or measured data exceed the limits for group 2 instruments; therefore, no further supply of particular information about conditions for exceeding these limits is required.

Annex B (informative)

Guidance for safe use of the fundus camera

When a fundus camera is classified as a group 1 device, it is considered as non-hazardous. If a camera has been found to be a group 2 instrument, information about aphakic hazard shall be provided in the manual.

If a fundus camera is capable of emitting more radiation than specified for group 2 instruments according to ISO 15004-2, the manufacturer should provide additional information. This is to inform the user about potential optical radiation hazards that may be associated with the use of the fundus camera. It is not reasonable to set limits on visible and infrared radiation that may be needed for the diagnosis of disease. A clinician may need to exceed an exposure level that is known to be potentially hazardous during an extended ocular examination for diagnosis of ocular pathology.

The guidance should contain information on the manner of use that may lead to exceeding the limit(s). This includes, for example, information about maximum settings of illumination or flash, angular field of view, filter settings, etc. and the exposure. It is not required to refer to the special light hazard limits of ISO 15004-2 in detail.

It is recommended to provide the user with default settings for the typical use in each application mode.

An example of the cautionary statement and the recommended settings is given here.

“CAUTION — The light emitted by the fundus camera is potentially hazardous. The longer the duration of exposure and the greater the number of pulses, the greater the risk of ocular damage. Exposure with light from this instrument, when operated at the following settings, will exceed the safety guideline:

- **More than 10 pulses with flash level ___ and angular field ___ in the ___ mode!**
- **More than 90 min with intensity ___ at angular field ___ in the ___ mode!”**

Recommended settings for typical examinations:

Operation mode	Default settings	Exposure time	Number of pulses
Colour	Illumination level: 10 Flash level: 12 Field: narrow	3 min	2 – 3
FA (Fluorescein angiography)	Illumination level: 22 Flash level: 16 – 24 Field: regular	1st session of 3 min, 2nd session of 2 min, intermission of 5 min – 10 min	10 – 15 in the 1st session, 5 in the 2nd session
ICG (Indocyanide green)	Illumination level: 18 Flash level: 18 – 26 Field: regular	1st session of 3 min, 2nd session of 2 min, intermission of 5 min – 10 min	10 – 15 in the 1st session, 5 in the 2nd session

ICS 11.040.70

Price based on 12 pages

© ISO 2009 – All rights reserved



医课汇
公众号
专业医疗器械资讯平台
WECHAT OF
HLONGMED



hlongmed.com
医疗器械咨询服务
MEDICAL DEVICE
CONSULTING
SERVICES



医课培训平台
医疗器械任职培训
WEB TRAINING
CENTER



医械宝
医疗器械知识平台
KNOWLEDG
ECENTEROF
MEDICAL DEVICE



MDCPP.COM
医械云专业平台
KNOWLEDG
ECENTEROF MEDICAL
DEVICE