

INTERNATIONAL STANDARD



AMENDMENT 2

Medical electrical equipment – Part 1: General requirements for basic safety and essential performance



THIS PUBLICATION IS COPYRIGHT PROTECTED
Copyright © 2020 IEC, Geneva, Switzerland

All rights reserved. Unless otherwise specified, no part of this publication may be reproduced or utilized in any form or by any means, electronic or mechanical, including photocopying and microfilm, without permission in writing from either IEC or IEC's member National Committee in the country of the requester. If you have any questions about IEC copyright or have an enquiry about obtaining additional rights to this publication, please contact the address below or your local IEC member National Committee for further information.

IEC Central Office
3, rue de Varembe
CH-1211 Geneva 20
Switzerland

Tel.: +41 22 919 02 11
info@iec.ch
www.iec.ch

About the IEC

The International Electrotechnical Commission (IEC) is the leading global organization that prepares and publishes International Standards for all electrical, electronic and related technologies.

About IEC publications

The technical content of IEC publications is kept under constant review by the IEC. Please make sure that you have the latest edition, a corrigendum or an amendment might have been published.

IEC publications search - webstore.iec.ch/advsearchform

The advanced search enables to find IEC publications by a variety of criteria (reference number, text, technical committee,...). It also gives information on projects, replaced and withdrawn publications.

IEC Just Published - webstore.iec.ch/justpublished

Stay up to date on all new IEC publications. Just Published details all new publications released. Available online and once a month by email.

IEC Customer Service Centre - webstore.iec.ch/csc

If you wish to give us your feedback on this publication or need further assistance, please contact the Customer Service Centre: sales@iec.ch.

Electropedia - www.electropedia.org

The world's leading online dictionary on electrotechnology, containing more than 22 000 terminological entries in English and French, with equivalent terms in 16 additional languages. Also known as the International Electrotechnical Vocabulary (IEV) online.

IEC Glossary - std.iec.ch/glossary

67 000 electrotechnical terminology entries in English and French extracted from the Terms and definitions clause of IEC publications issued between 2002 and 2015. Some entries have been collected from earlier publications of IEC TC 37, 77, 86 and CISPR.



IEC 60601-1

Edition 3.0 2020-08

INTERNATIONAL STANDARD



AMENDMENT 2

**Medical electrical equipment –
Part 1: General requirements for basic safety and essential performance**

INTERNATIONAL
ELECTROTECHNICAL
COMMISSION

ICS 11.040.01

ISBN 978-2-8322-8632-6

Warning! Make sure that you obtained this publication from an authorized distributor.

FOREWORD

This amendment has been prepared by subcommittee 62A: Common aspects of electrical equipment used in medical practice, of IEC technical committee 62: Electrical equipment in medical practice.

The text of this amendment is based on the following documents:

| FDIS | Report on voting |
|---------------|------------------|
| 62A/1389/FDIS | 62A/1404/RVD |

Full information on the voting for the approval of this amendment can be found in the report on voting indicated in the above table.

The committee has decided that the contents of this amendment and the base publication will remain unchanged until the stability date indicated on the IEC web site under "<http://webstore.iec.ch>" in the data related to the specific publication. At this date, the publication will be

- reconfirmed,
- withdrawn,
- replaced by a revised edition, or
- amended.

NOTE The attention of the users of this document is drawn to the fact that equipment manufacturers and testing organizations may need a transitional period following publication of a new, amended or revised IEC or ISO publication in which to make products in accordance with the new requirements and to equip themselves for conducting new or revised tests. It is the recommendation of the committee that the content of this publication be adopted for mandatory implementation nationally not earlier than 3 years from the date of publication.

IMPORTANT – The 'colour inside' logo on the cover page of this publication indicates that it contains colours which are considered to be useful for the correct understanding of its contents. Users should therefore print this document using a colour printer.

INTRODUCTION TO AMENDMENT 2

The third edition of IEC 60601-1 was published in 2005 and amended in 2012. Since the publication of IEC 60601-1:2005/AMD1:2012, the IEC Subcommittee (SC) 62A Secretariat has been collecting issues from a variety of sources including comments from National Committees and questions submitted to IEC/SC 62A/Working Group (WG) 14. At the November 2015 meeting of IEC/SC 62A in Kobe, Japan, the subcommittee initiated a process to identify high-priority issues that need to be considered in Amendment 2 and should not wait until the fourth edition of IEC 60601-1, which is presently targeted for publication sometime after 2024.

Those issues selected for inclusion on the final "short list" to be addressed in Amendment 2 were those approved by a 2/3 majority of the National Committees present and voting at the Frankfurt meeting of SC 62A. At the meeting held on 10 October 2016, 109 items were presented to the National Committees present. A total of 78 items received the required 2/3 majority of the National Committees present and voting and were included in the "short list" for consideration in preparing Amendment 2. All remaining issues have been placed on a "long list" for consideration in the fourth edition of IEC 60601-1.

The "short list" of issues was documented in the design specification for Amendment 2. The responsible expert groups were directed to consider each issue assigned to it in Clause 6 of the design specification and develop an appropriate solution for the identified problem. That final solution in this amendment can encompass any technical solution proposed by the author of the issue or it can involve a different solution developed by the expert group. The expert group can also have recommended that no change to the standard was justified by the problem statement.

Because this is an amendment to the 2005 edition of IEC 60601-1, the style in force at the time of publication of IEC 60601-1 has been applied to this amendment. The style specified in ISO/IEC Directives, Part 2:2018 has only been applied when implementing the new style guidance would not result in additional editorial changes. For example, notes to definitions are designated as "NOTE" rather than "Note to entry" in Clause 3.

Users of this document should note that when constructing the dated references to specific elements in a standard, such as definitions, amendments are only referenced if they modified the text being cited. For example, if a reference is made to a definition that has not been modified by an amendment, then the reference to the amendment is not included in the dated reference.

INTRODUCTION

Add, after the existing last paragraph, the following paragraph:

Throughout this document, there are many references to, and requirements incorporated from IEC 60950-1. Some of these requirements are derived from IEC 60950-1. For example, the requirements for spaces filled by insulating compound in 8.9.3. In other cases, the requirements are incorporated by a normative reference to IEC 60950-1:2005. For example, the requirements for solid insulation forming a MEANS OF OPERATOR PROTECTION in 8.5.1.3. The requirements incorporated by reference are primarily found in Clause 8 of this document, including many of the tables used to determine the requirements for MEANS OF PROTECTION, primarily MEANS OF OPERATOR PROTECTION and INSULATION CO-ORDINATION. The requirements incorporated by reference are addressed in Amendment 2. The derived requirements will be addressed during the development of the fourth edition of this document.

1.3 * Collateral standards

Replace the existing second paragraph with:

Applicable collateral standards shall apply together with this standard.

Delete the existing third paragraph.

1.4 * Particular standards

Replace the existing first paragraph with:

In the IEC 60601 series, particular standards specify BASIC SAFETY and ESSENTIAL PERFORMANCE requirements for the particular ME EQUIPMENT and ME SYSTEMS. Particular standards may modify, replace or delete requirements contained in this standard and applicable collateral standards as appropriate for the particular ME EQUIPMENT and ME SYSTEMS under consideration.

Replace the existing second paragraph with:

A requirement of a particular standard takes priority over this standard and applicable collateral standards.

2 * Normative references

Replace the existing second paragraph with:

ATTENTION: Additional collateral standards of the IEC 60601 series, which are issued subsequent to publication of this standard, shall apply together with this standard when applicable. They shall be considered as being included among the normative references below. See 1.3.

Replace the following existing references to IEC 60601-1-2, IEC 60601-1-3 modified by Amendment 1, IEC 60601-1-6 and IEC 60601-1-8 by the following new references:

IEC 60601-1-2:2014, *Medical electrical equipment – Part 1-2: General requirements for basic safety and essential performance – Collateral standard: Electromagnetic disturbances – Requirements and tests*
Amendment 1:2020

IEC 60601-1-3:2008, *Medical electrical equipment – Part 1-3: General requirements for basic safety and essential performance – Collateral Standard: Radiation protection in diagnostic X-ray equipment*
Amendment 1:2013

IEC 60601-1-6:2010, *Medical electrical equipment – Part 1-6: General requirements for basic safety and essential performance – Collateral standard: Usability*
Amendment 1:2013
Amendment 2:2020

IEC 60601-1-8:2006, *Medical electrical equipment – Part 1-8: General requirements for basic safety and essential performance – Collateral standard: General requirements, tests and guidance for alarm systems in medical electrical equipment and medical electrical systems*
Amendment 1:2012
Amendment 2:2020

Add the following new reference to the list:

IEC 60747-5-5:2007, *Semiconductor devices – Discrete devices – Part 5-5: Optoelectronic devices – Photocouplers*

Replace, in the existing reference to IEC 60825-1, "2007" with "2014".

Replace the existing references to IEC 60950-1 and IEC 62304 by the following new references:

IEC 60950-1:2005, *Information technology equipment – Safety – Part 1: General requirements*
Amendment 1:2009
Amendment 2:2013

IEC 62304:2006, *Medical device software – Software life cycle processes*
Amendment 1:2015

Add the following normative references to the existing list:

IEC 62133-2, *Secondary cells and batteries containing alkaline or other non-acid electrolytes – Safety requirements for portable sealed secondary lithium cells, and for batteries made from them, for use in portable applications – Part 2: Lithium systems*

IEC 62368-1:2018, *Audio/video, information and communication technology equipment – Part 1: Safety requirements*

Replace the existing references to ISO 7000-DB:2004 by the following new reference:
ISO 7000, *Graphical symbols for use on equipment*

Replace, in the existing reference to ISO 7010, "2011" with "2019".

Replace, in the existing reference to ISO 14971, "2007" with "2019".

Replace, in the existing reference to ISO 15223-1, "2012" with "2016".

3 * Terminology and definitions

3.38

*** HARM**

Replace the existing term and definition, modified by Amendment 1, with:

3.38

*** HARM**

injury or damage to the health of people or animals, or damage to property or the environment

[ISO 14971:2019, definition 3.3, modified – "Or animals" added to the definition.]

3.39
HAZARD

Replace the existing source statement for definition, modified by Amendment 1, with:

[ISO 14971:2019, definition 3.4]

3.40
*** HAZARDOUS SITUATION**

Replace the existing term and definition, modified by Amendment 1, with:

3.40
*** HAZARDOUS SITUATION**

circumstance in which people, property, or the environment is/are exposed to one or more HAZARDS

[ISO 14971:2019, definition 3.5, modified – Note 1 to entry deleted.]

3.44
INTENDED USE
INTENDED PURPOSE

Replace the existing term and definition, modified by Amendment 1, with:

3.44
INTENDED USE
INTENDED PURPOSE

use for which a product, PROCESS or service is intended according to the specifications, instructions and information provided by the MANUFACTURER

NOTE 1 The intended medical indication, PATIENT population, part of the body or type of tissue interacted with, user profile, use environment, and operating principle are typical elements of the INTENDED USE.

NOTE 2 INTENDED USE should not be confused with NORMAL USE. While both include the concept of use as intended by the MANUFACTURER, INTENDED USE focuses on the medical purpose while NORMAL USE incorporates not only the medical purpose, but maintenance, transport, etc. as well.

[ISO 14971:2019, definition 3.6, modified – Note 2 added.]

3.55
MANUFACTURER

Replace the existing term and definition, modified by Amendment 1, with:

3.55
MANUFACTURER

natural or legal person with responsibility for the design, manufacture, packaging, or labelling of ME EQUIPMENT, assembling an ME SYSTEM, or adapting ME EQUIPMENT or an ME SYSTEM, regardless of whether these operations are performed by that person himself or on his behalf by another person(s)

NOTE 1 ISO 13485 [30] defines “labelling” as “label, instructions for use, and any other information that is related to identification, technical description, INTENDED PURPOSE and proper use of the ME EQUIPMENT or ME SYSTEM, but excluding shipping documents”.

NOTE 2 “Adapting” includes making substantial modifications to ME EQUIPMENT or an ME SYSTEM already in use.

NOTE 3 In some jurisdictions, the RESPONSIBLE ORGANIZATION can be considered a MANUFACTURER when involved in the activities described.

NOTE 4 Adapted from ISO 14971:2019, definition 3.9.

3.72
OBJECTIVE EVIDENCE

Replace the existing source statement for definition, modified by Amendment 1, with:

[ISO 14971:2019, definition 3.11]

3.88
PROCEDURE

Replace the existing source statement for definition, modified by Amendment 1, with:

[ISO 14971:2019, definition 3.13, modified – Note 1 to entry deleted.]

3.89
PROCESS

Replace the existing term and definition, modified by Amendment 1, with:

3.89
PROCESS

set of interrelated or interacting activities that use inputs to deliver an intended result

NOTE 1 Whether the “intended result” of a PROCESS is called output, product or service depends on the context of the reference.

NOTE 2 Inputs to a PROCESS are generally the outputs of other PROCESSES and outputs of a PROCESS are generally the inputs to other PROCESSES.

NOTE 3 Two or more interrelated and interacting PROCESSES in series can also be referred to as a PROCESS.

[ISO 14971:2019, definition 3.14]

3.98
RECORD

Add the following NOTES and replace the existing source statement for definition, modified by Amendment 1, with:

NOTE 1 RECORDS can be used, for example, to formalize traceability and to provide evidence of VERIFICATION, preventive action and corrective action.

NOTE 2 Generally RECORDS need not be under revision control.

[ISO 14971:2019, definition 3.16]

3.100
RESIDUAL RISK

Replace the existing term and definition, modified by Amendment 1, with:

3.100
RESIDUAL RISK

RISK remaining after RISK CONTROL measures have been implemented

[ISO 14971:2019, definition 3.17]

3.102
RISK

Replace the existing source statement for definition, modified by Amendment 1, with:

[ISO 14971:2019, definition 3.18]

3.103
RISK ANALYSIS

Replace the existing source statement for definition, modified by Amendment 1, with:

[ISO 14971:2019, definition 3.19]

3.104
RISK ASSESSMENT

Replace the existing source statement for definition, modified by Amendment 1, with:

[ISO 14971:2019, definition 3.20]

3.105
RISK CONTROL

Replace the existing source statement for definition, modified by Amendment 1, with:

[ISO 14971:2019, definition 3.21]

3.106
RISK EVALUATION

Replace the existing source statement for definition, modified by Amendment 1, with:

[ISO 14971:2019, definition 3.23]

3.107
RISK MANAGEMENT

Replace the existing term and definition, modified by Amendment 1, with:

3.107
RISK MANAGEMENT

systematic application of management policies, PROCEDURES and practices to the tasks of analysing, evaluating, controlling and monitoring RISK

NOTE For the purposes of this standard, RISK MANAGEMENT does not include planning for or monitoring of production and post-production information; whereas this is required for compliance with ISO 14971 (see 4.2.2).

[ISO 14971:2019, definition 3.24, modified – NOTE added.]

3.108
RISK MANAGEMENT FILE

Replace the existing NOTE and source statement for definition, modified by Amendment 1, with:

NOTE All safety related information including MANUFACTURER'S calculations, test results, etc. is considered to be part of the RISK MANAGEMENT FILE. See also 4.2.

[ISO 14971:2019, definition 3.25, modified – NOTE added.]

3.114
SEVERITY

Replace the existing source statement for definition, modified by Amendment 1, with:

[ISO 14971:2019, definition 3.27]

3.136**USABILITY**

Replace the existing term and definition, modified by Amendment 1, with:

3.136**USABILITY**

characteristic of the OPERATOR interface that facilitates use and thereby establishes effectiveness, efficiency, and OPERATOR satisfaction in the intended use environment

[IEC 62366-1:2015, definition 3.16, modified – Replace "user" with "OPERATOR" in two places and delete Note 1 to entry.]

3.137**USABILITY ENGINEERING**

Replace the existing term and definition, modified by Amendment 1, with:

3.137**USABILITY ENGINEERING****HUMAN FACTORS ENGINEERING**

application of knowledge about human behaviour, abilities, limitations, and other characteristics to the design of ME EQUIPMENT (including software), systems and tasks to achieve adequate USABILITY

[IEC 62366-1:2015, definition 3.17, modified – Replace "medical devices" with "ME EQUIPMENT" and delete Note 1 to entry.]

3.138**VERIFICATION**

Replace the existing NOTES and source statement or definition, modified by Amendment 1, with:

NOTE 1 The OBJECTIVE EVIDENCE needed for a VERIFICATION can be the result of an inspection or of other forms of determination such as performing alternative calculations or reviewing documents.

NOTE 2 The activities carried out for VERIFICATION are sometimes called a qualification PROCESS.

NOTE 3 The word "verified" is used to designate the corresponding status.

[ISO 14971:2019, definition 3.31]

3.146**PRIMARY OPERATING FUNCTION**

Replace the existing term and definition, added by Amendment 1, with:

3.146**PRIMARY OPERATING FUNCTION**

function that involves OPERATOR interaction that is related to the safety of the ME EQUIPMENT

[IEC 62366-1:2015, definition 3.11, modified – Replace "user" with "OPERATOR" and "medical device" with "ME EQUIPMENT", and delete Note 1 to entry and Note 2 to entry.]

3.147**USABILITY ENGINEERING FILE**

For the existing definition, added by Amendment 1, replace "[IEC 62366:2007, definition 3.19]" with "[IEC 62366-1:2015, definition 3.18]".

Add, after the existing definition 3.147, added by Amendment 1, the following new terms and definitions:

3.148

ELECTROMAGNETIC DISTURBANCE

EM DISTURBANCE

any electromagnetic phenomenon that could degrade the performance of a device, equipment or system

NOTE An ELECTROMAGNETIC DISTURBANCE can be electromagnetic noise, an unwanted signal or a change in the propagation medium itself.

[IEC 60601-1-2:2014, definition 3.3]

3.149

HIGH PRIORITY

indicating that immediate OPERATOR response is required

NOTE 1 The priority is assigned through RISK ANALYSIS.

NOTE 2 Immediate implies the interruption of current workflow is expected.

[IEC 60601-1-8:2006 and IEC 60601-1-8:2006/AMD2:2020, definition 3.22, modified – Internal reference to IEC 60601-1-8, 6.1.2 in NOTE 1 deleted and bibliographic citations removed from NOTE 2.]

3.150

*** INFORMATION SIGNAL**

any signal that is not an ALARM SIGNAL or a reminder signal

EXAMPLE 1 ECG waveform

EXAMPLE 2 SpO2 tone

EXAMPLE 3 Fluoroscopy beam-on indication

NOTE An advisory is a type of INFORMATION SIGNAL.

[SOURCE: IEC 60601-1-8:2006 and IEC 60601-1-8:2006/AMD2:2020, definition 3.23]

3.151

LOW PRIORITY

indicating that OPERATOR awareness is required and future action might be needed

NOTE 1 The priority is assigned through RISK ANALYSIS.

NOTE 2 Awareness implies the planning of future workflow is expected.

[IEC 60601-1-8:2006/AMD2:2020, definition 3.27, modified – Internal reference to IEC 60601-1-8, 6.1.2 in NOTE 1 deleted and bibliographic citations removed from NOTE 2.]

3.152

*** MAXIMUM EQUIPMENT PRESSURE**

the maximum gauge pressure to which a part of ME EQUIPMENT can be subjected in NORMAL CONDITION and SINGLE FAULT CONDITION

3.153

MEDIUM PRIORITY

indicating that prompt OPERATOR response is required

NOTE 1 The priority is assigned through RISK ANALYSIS.

NOTE 2 Prompt implies the re-planning of current workflow is expected.

[IEC 60601-1-8:2006 and IEC 60601-1-8:2006/AMD2:2020, definition 3.28, modified – Internal reference to IEC 60601-1-8, 6.1.2 in NOTE 1 deleted and bibliographic citations removed from NOTE 2.]

3.154

SAFETY SIGN

sign giving a general safety message, obtained by a combination of a colour and geometric shape and which, by the addition of a graphical symbol, gives a general or particular safety message

[ISO 7010:2019, definition 3.3, modified – Replace "gives a particular safety message" with "gives a general or particular safety message".]

4.2.1 Introduction to RISK MANAGEMENT

Replace, in the existing second paragraph, added by Amendment 1, "ISO 14971" with "ISO 14971:2019" (3 places).

4.2.2 General requirement for RISK MANAGEMENT

Replace, in the introductory paragraph before the dashes, added by Amendment 1, "ISO 14971:2007" with "ISO 14971:2019".

Replace the existing first and second dashes, added by Amendment 1, with:

- the planning for and execution of production and post-production monitoring (subclause 4.1, fourth dash, subclause 4.4, item g), and Clause 10 of ISO 14971:2019), and
- periodic reviews of the suitability of the RISK MANAGEMENT PROCESS (third paragraph of ISO 14971:2019, subclause 4.2).

Figure 6 – Standard test finger (see 5.9.2.1)

Replace, in the existing NOTE 3 of this figure, the reference to "IEC 60950-1" with "IEC 60950-1:2005".

6.3 * Protection against harmful ingress of water or particulate matter

Delete, in the existing title, the asterisk ().*

7.1.2 * Legibility of markings

Replace, in the existing first dash, "safety signs" with "SAFETY SIGNS".

7.2.3 * Consult ACCOMPANYING DOCUMENTS

Replace the existing subclause, modified by Amendment 1, with:

When the MANUFACTURER uses consulting the ACCOMPANYING DOCUMENTS as a primary RISK CONTROL measure for a specific RISK (e.g. the instructions for use contain information for safety) and the USABILITY ENGINEERING PROCESS determines that marking the ME EQUIPMENT is required for the effectiveness of the RISK CONTROL, the ME EQUIPMENT shall be marked with the refer to instruction manual/booklet mandatory action SAFETY SIGN ISO 7010-M002 (see Table D.2, SAFETY SIGN 10).

Otherwise, symbol ISO 7000-1641 (2004-01) (see Table D.1, symbol 11) may be used to advise the OPERATOR of the location of the instructions for use or to consult the ACCOMPANYING DOCUMENTS.

7.2.5 ME EQUIPMENT intended to receive power from other equipment

Replace, in the existing second dash modified by Amendment 1, "safety sign" with "SAFETY SIGN" in two places.

7.2.9 IP classification

Replace the existing second paragraph with:

If the IP classification of the ENCLOSURE of the ME EQUIPMENT or its parts is not specified (i.e. IPXX) or is specified as IP00, IPX0 or IPOX, then the ME EQUIPMENT or its parts need not be marked as such.

7.2.10 * APPLIED PARTS

Replace, in the final paragraph, "safety sign" with "SAFETY SIGN" in two places.

7.2.13 Physiological effects (safety signs and warning statements)

Replace, in the existing title, "safety signs" with "SAFETY SIGNS", and in the existing first paragraph, "safety sign" with "SAFETY SIGN" in two places.

7.2.17 Protective packaging

Replace, in the existing third paragraph, "safety sign" with "SAFETY SIGN".

7.3.2 * HIGH VOLTAGE parts

Replace, in the existing paragraph, modified by Amendment 1, "safety sign" with "SAFETY SIGN".

7.3.3 Batteries

Replace the existing third paragraph with:

Where lithium batteries or fuel cells are incorporated and where incorrect replacement (e.g. reversed polarity) would result in a HAZARDOUS SITUATION (such as excessive temperatures, fire or explosion), a warning indicating that replacement by inadequately trained personnel could result in such a HAZARDOUS SITUATION shall be given in addition to the identifying marking referring to information stated in the ACCOMPANYING DOCUMENTS.

7.3.7 Supply terminals

Delete, in the existing first paragraph, modified by Amendment 1, "unless it can be demonstrated that no unacceptable RISK can result if connections are interchanged".

7.4.1 * Power switches

Delete, in the existing first paragraph modified by Amendment 1, "or its parts,".

Add, after the third dash of the existing third paragraph modified by Amendment 1, the following paragraphs:

Switches used to control power to parts of ME EQUIPMENT shall have their "on" and "off" positions:

- marked with symbols as specified above; or
- with IEC 60417-5264 (2002-10) and IEC 60417-5265 (2002-10) (see Table D.1, symbols 16 and 17); or

- indicated by an adjacent indicator light; or
- indicated by other unambiguous means.

A switch that brings the ME EQUIPMENT into the "stand-by" condition may be indicated by use of symbol IEC 60417-5009 (2015-03) (see Table D.1, Symbol 29).

7.4.2 * Control devices

Delete, in the existing first paragraph, modified by Amendment 1, ", e.g. by use of symbols IEC 60417-5264 (2002-10) and IEC 60417-5265 (2002-10) (see Table D.1, symbols 16 and 17)"

Delete the existing final paragraph, modified by Amendment 1.

7.5 Safety signs

Replace, in the existing title, "Safety signs" with "SAFETY SIGNS", in the existing first paragraph, modified by Amendment 1, "safety sign" with "SAFETY SIGN" in three places, and in the existing second paragraph, "safety sign" with "SAFETY SIGN".

Replace, in existing list item a), "safety sign" with "SAFETY SIGN" and "safety signs" with "SAFETY SIGNS".

Replace, in existing list items b), c) and d), "safety sign" with "SAFETY SIGN".

Replace, in the existing third paragraph, "safety sign" with "SAFETY SIGN", and in NOTE 2, replace "safety signs" with "SAFETY SIGNS".

Replace, in the existing fourth and fifth paragraphs, "safety signs" with "SAFETY SIGNS".

7.8.1 Colours of indicator lights

Add an asterisk () at the beginning of the subclause title.*

Table 2 – Colours of indicator lights and their meaning for ME EQUIPMENT

Replace the existing table and its title with the following new table:

Table 2 – Colours and meanings of indicator lights and alarm indicator lights for ME EQUIPMENT

| Name | On when | Indicator light ^a | Alarm indicator light | Accompanied by sound | Operator requirement |
|---------------------------------|--|--|---|------------------------|---|
| Warning ^b | HAZARDOUS SITUATION is to be avoided | Red, not flashing | – | – ^c | Avoidance of a HAZARDOUS SITUATION which could cause death or serious injury |
| Caution ^b | HAZARDOUS SITUATION is to be avoided | Yellow, not flashing | – | – | Avoidance of a HAZARDOUS SITUATION which could cause minor or moderate injury or equipment damage |
| Ready for use | ME EQUIPMENT is ready for use | Green | – | – | – |
| HIGH PRIORITY ALARM CONDITION | Interruption of current workflow is needed | – | Red, flashing ^d | Typically ^d | Immediate action to prevent injury |
| MEDIUM PRIORITY ALARM CONDITION | Re-planning of current workflow is needed | – | Yellow, flashing ^d | Typically ^d | Prompt action to prevent injury |
| LOW PRIORITY ALARM CONDITION | Planning of future workflow is needed | – | Yellow or cyan, not flashing ^d | Optional ^d | Awareness for future action |
| Other | Situations other than that of red, yellow or green | Any colour other than red, yellow, cyan or green | – | – | – |

^a These indicator lights are INFORMATION SIGNALS and IEC 60601-1-8 requires that they be perceived as different than visual ALARM SIGNALS.

^b Such warnings and cautions are frequently accompanied by a SAFETY SIGN.

^c Sound may be utilized, but IEC 60601-1-8 requires that it be perceived as different than auditory ALARM SIGNALS.

^d As specified in IEC 60601-1-8.

7.9.2.1 * General

Replace, in the existing fourth paragraph, "safety signs" with "SAFETY SIGNS".

7.9.3.1 * General

Replace, in the second dash of the existing second paragraph, modified by Amendment 1, "safety signs" with "SAFETY SIGNS".

8.4.2 ACCESSIBLE PARTS and APPLIED PARTS

Renumber the existing NOTE as NOTE 1.

Add, after the final paragraph of existing list item c) modified by Amendment 1, the following text:

If the ME EQUIPMENT has SIP/SOP connectors or separate power supply output connectors, measure the voltage of all conductive ACCESSIBLE PARTS of the SIP/SOP connectors or power output connectors to earth:

- *Connect a resistor of $10\text{ k}\Omega \pm 500\ \Omega$ (8 W for measurements up to 280 V r.m.s.) between the SIP/SOP-pin (or other output connector) to earth.*
- *Connect in parallel to the $10\text{ k}\Omega$ resistor a peak voltmeter or an oscilloscope to measure the voltage.*

If the voltage measured above is less than or equal to 60 V d.c. or 42,4 V peak a.c., a subsequent LEAKAGE CURRENT test is not necessary.

NOTE 2 A similar approach exists in IEC 60950-1:2005, 1.4.9.

NOTE 3 $10\text{ k}\Omega$ has been selected, because it is a value higher than the body impedance of the OPERATOR ($= 1\text{ k}\Omega$) and lower than the expected impedance of the insulation barrier (approximately $1\text{ M}\Omega$). Furthermore, IEC 60950-1:2005, 1.4.9 used a $5\text{ k}\Omega$ resistor and therefore using a $10\text{ k}\Omega$ resistor provides greater safety.

If the voltage measurement above exceeds the specified levels, then the TOUCH CURRENT from SIP/SOP connectors to earth and from any separate power supply output connectors to earth shall be measured.

Measure the TOUCH CURRENT derived from the SUPPLY MAINS by applying the limits in 8.7.3 c) from the connectors described above in:

- *NORMAL CONDITION including open FUNCTIONAL EARTH CONDUCTOR (if applicable); and*
- *SINGLE FAULT CONDITION (respectively open neutral conductor; open PROTECTIVE EARTH CONDUCTOR (if applicable)).*

NOTE 4 If the SIP/SOP circuit is completely isolated from the floating (non-earth referenced) SECONDARY CIRCUIT by an own insulation barrier of at least 1 MOOP based on MAINS VOLTAGE, i.e. a SEPARATION DEVICE according to 16.5, the measurement of the SIP/SOP connector to earth TOUCH CURRENT does not need to be conducted. In such cases it is sufficient to evaluate the effectiveness of the SEPARATION DEVICE by measurement according to 8.7.4.7 c).

NOTE 5 For CLASS I ME EQUIPMENT with earth referenced SECONDARY CIRCUITS in NORMAL CONDITION, the LEAKAGE CURRENT derived from the SUPPLY MAINS will be superimposed by the secondary voltage generated current. However, the SUPPLY MAINS derived LEAKAGE CURRENT will usually be equal to the TOUCH CURRENT measured on parts connected to the PROTECTIVE EARTH TERMINAL both in NORMAL CONDITION and in SINGLE FAULT CONDITION (open neutral conductor; open PROTECTIVE EARTH CONDUCTOR). If in doubt, the measurement can usually be done by setting the voltage meter to AC-measurement only or by using an oscilloscope or any other equivalent method to assure that the secondary voltage will not influence the measurement result.

8.5.1.1 General

Replace the existing second paragraph with:

Each MEANS OF PROTECTION shall be categorized in relation to the ME EQUIPMENT part(s) which it protects from exceeding permitted limits. It is a MEANS OF PATIENT PROTECTION if it protects APPLIED PARTS or parts that are identified according to 4.6 as needing to be subject to the same requirements as APPLIED PARTS. Otherwise the requirements for either MOPP or MOOP shall be used as shown in Figure 40.

Replace the existing NOTE, modified by Amendment 1, with:

NOTE Coatings and other insulation that are intended as a MEANS OF PROTECTION and that comply with IEC 60950-1:2005 or IEC 62368-1:2018 can be used as a MEANS OF OPERATOR PROTECTION but not automatically as a MEANS OF PATIENT PROTECTION. For MEANS OF PATIENT PROTECTION, considerations can arise as a result of the RISK MANAGEMENT PROCESS.

Add, after the existing sixth paragraph, added by Amendment 1, the following new figure:

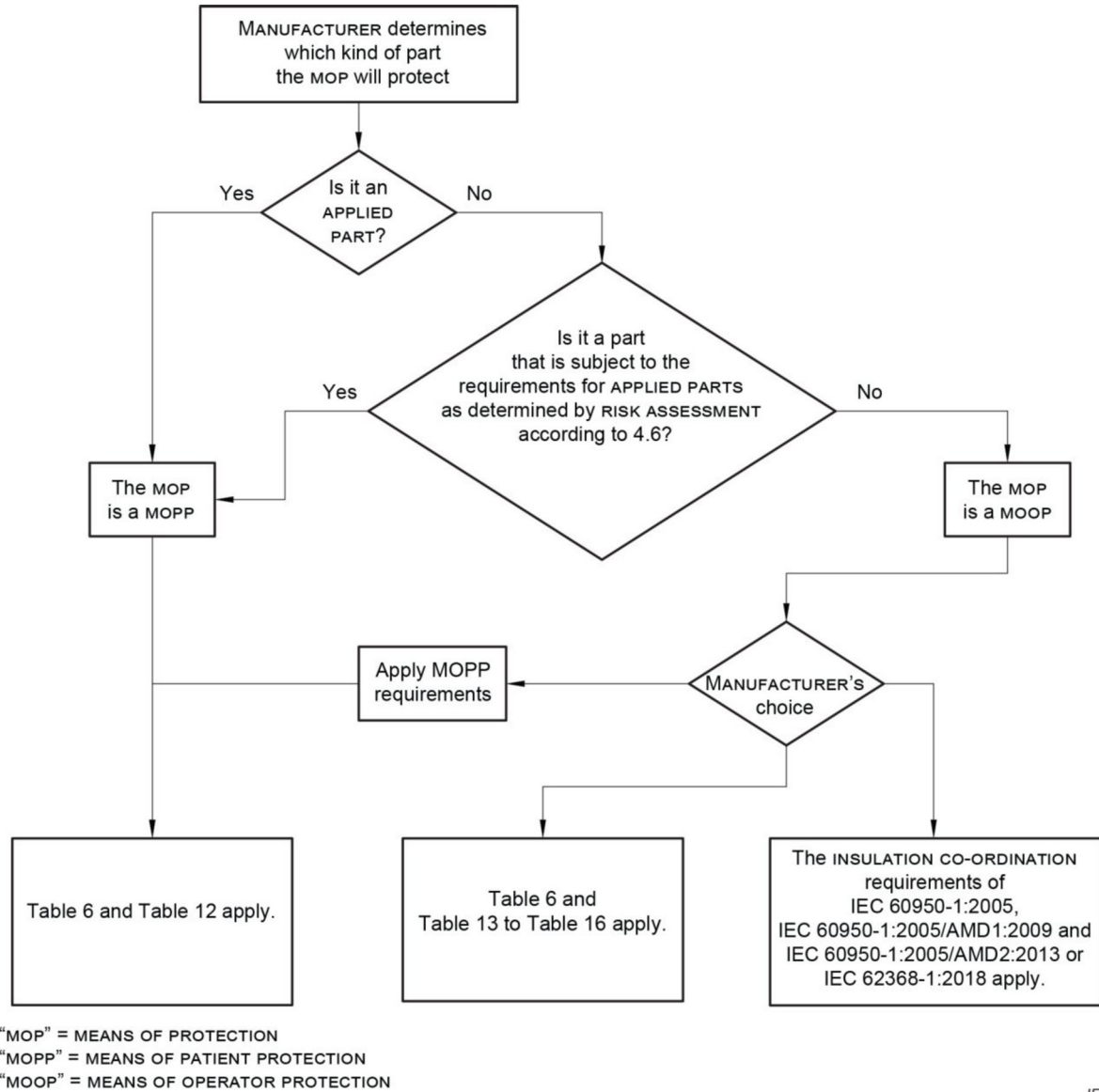

IEC

Figure 40 – Identification of MEANS OF PATIENT PROTECTION and MEANS OF OPERATOR PROTECTION

8.5.1.2 * MEANS OF PATIENT PROTECTION (MOPP)

Add, after the existing second paragraph, the following NOTES:

NOTE 1 Barriers providing 2 MOOP with AIR CLEARANCE values according to Table 13 to Table 15 (inclusive) or according to IEC 60950-1:2005, IEC 60950-1:2005/AMD1:2009 and IEC 60950-1:2005/AMD2:2013 meet the requirements for 1 MOPP according to Table 12 for WORKING VOLTAGES up to 707 V d.c. / 500 V r.m.s. At higher WORKING VOLTAGES, 2 MOOP does not necessarily provide 1 MOPP.

Barriers providing REINFORCED INSULATION (2 MOOP) with AIR CLEARANCE values according to IEC 62368-1:2018 for WORKING VOLTAGES up to and including 354 V d.c. / 250 V r.m.s. meets the requirements for 1 MOPP according to Table 12. At higher WORKING VOLTAGES, REINFORCED INSULATION (2 MOOP) does not necessarily provide 1 MOPP.

See also 8.5.1.3.

NOTE 2 Barriers providing REINFORCED INSULATION (2 MOOP) with CREEPAGE DISTANCES according to IEC 62368-1:2018, Table 17 and Table 18 or IEC 60950-1:2005, IEC 60950-1:2005/AMD1:2009, IEC 60950-1:2005/AMD2:2013, Table 2N meet the requirements for 1 MOPP according to Table 12.

Add after the existing fifth paragraph, added by Amendment 1, the following text:

NOTE 3 When fitting Y capacitors across barriers, the dielectric strength requirement is to be considered. For example, for voltages in the range of 212 V peak to 354 V peak, two MEANS OF PATIENT PROTECTION are tested at 4 000 V a.c.; therefore, Y1 capacitors are used. Two Y2 capacitors in series would not withstand this voltage as they are rated at 1 500 V a.c. each. For voltages below 212 V peak, two Y2 capacitors would suffice as the dielectric strength requirement is 3 000 V a.c.

Opto-couplers complying with IEC 60747-5-5:2007, or a later edition, are considered equivalent to the requirements of 8.8.2 and 8.9.3.

All of the following apply:

- AIR CLEARANCE at the outside of the opto-coupler;
- CREEPAGE DISTANCE at the outside of the opto-coupler; and
- dielectric strength across the opto-coupler.

NOTE 4 The factor of 1,6 on insulation test voltage is only used for thermal cycling tests (8.9.3), as also in other safety standards (e.g. IEC 62368-1, IEC 60950-1). IEC 60747-5-5 applies different test methods. Because compliance with IEC 60747-5-5 is regarded as equivalent to the thermal cycling test, the 1,6 factor is not required. This is the same approach used in IEC 62368-1:2018, 5.4.4.4.

NOTE 5 Distance through insulation (0,4 mm) and thermal cycling testing are not required because compliance with the component standards addresses the RISK of pin holes and thermal effects on the insulating compound.

8.5.1.3 MEANS OF OPERATOR PROTECTION (MOOP)

Replace the second dash of the existing first paragraph with:

- comply with the requirements of IEC 60950-1:2005, IEC 60950-1:2005/AMD1:2009 and IEC 60950-1:2005/AMD2:2013 for INSULATION CO-ORDINATION; or
- comply with the requirements of IEC 62368-1:2018 for INSULATION CO-ORDINATION.

Replace the second dash of the existing second paragraph with:

- comply with the requirements of IEC 60950-1:2005, IEC 60950-1:2005/AMD1:2009 and IEC 60950-1:2005/AMD2:2013 for INSULATION CO-ORDINATION; or
- comply with the requirements of IEC 62368-1:2018 for INSULATION CO-ORDINATION.

Replace the second dash of the existing third paragraph with:

- comply with the requirements and tests of IEC 60950-1:2005, IEC 60950-1:2005/AMD1:2009 and IEC 60950-1:2005/AMD2:2013 for protective earthing; or
- comply with the requirements of IEC 62368-1:2018 for protective earthing.

Add, after the existing fourth paragraph, added by Amendment 1, the following text:

Opto-couplers complying with IEC 60747-5-5:2007, or a later edition, are considered equivalent to the requirements of 8.8.2 for distances through solid insulation and 8.9.3 for spaces filled by insulating compound.

The following apply:

- AIR CLEARANCE at the outside of the opto-coupler;
- CREEPAGE DISTANCE at the outside of the opto-coupler; and
- dielectric strength across the opto-coupler.

NOTE 1 The factor of 1,6 on insulation test voltage is only used for thermal cycling tests (8.9.3), as also in other safety standards (e.g. IEC 62368-1, IEC 60950-1). IEC 60747-5-5 applies different test methods. Because compliance with IEC 60747-5-5 is regarded as equivalent to the thermal cycling test, the 1,6 factor is not required. This is the same approach used in IEC 62368-1:2018, 5.4.4.4.

NOTE 2 Distance through insulation (0,4 mm) and thermal cycling testing are not required because compliance with the component standards addresses the RISK of pin holes and thermal effects on the insulating compound.

Renumber the existing NOTE modified by Amendment 1 following the existing fifth paragraph, as "NOTE 3".

Replace, in the first, second and fourth dashes of the existing sixth paragraph, the reference to "IEC 60950-1" with "IEC 60950-1:2005, IEC 60950-1:2005/AMD1:2009 and IEC 60950-1:2005/AMD2:2013 or IEC 62368-1:2018".

Delete the existing seventh paragraph.

8.5.2.2 * TYPE B APPLIED PARTS

Add the following sentence at the end of the existing second dash of the first paragraph:

In this case, the test in 8.7.4.7 d) does not apply.

8.5.2.3 * PATIENT LEADS or PATIENT cables

Replace, in the existing first dash of the first paragraph, modified by Amendment 1, "remote" with "distal".

8.5.3 * MAXIMUM MAINS VOLTAGE

Replace, in the existing first dash, "unless this is" with "unless the highest RATED supply voltage is", and replace "250 V" with "240 V".

Replace, in the existing third dash, "250 V" with "240 V".

8.5.4 * WORKING VOLTAGE

Add before the existing first dash, the following text and figure:

- For WORKING VOLTAGE measurement, all circuits shall be connected to earth with the exception of floating parts providing at least one MEANS OF PROTECTION to earth in which case the highest measured voltage on either side of the barrier is the WORKING VOLTAGE (see Figure 41).

www.intel.com

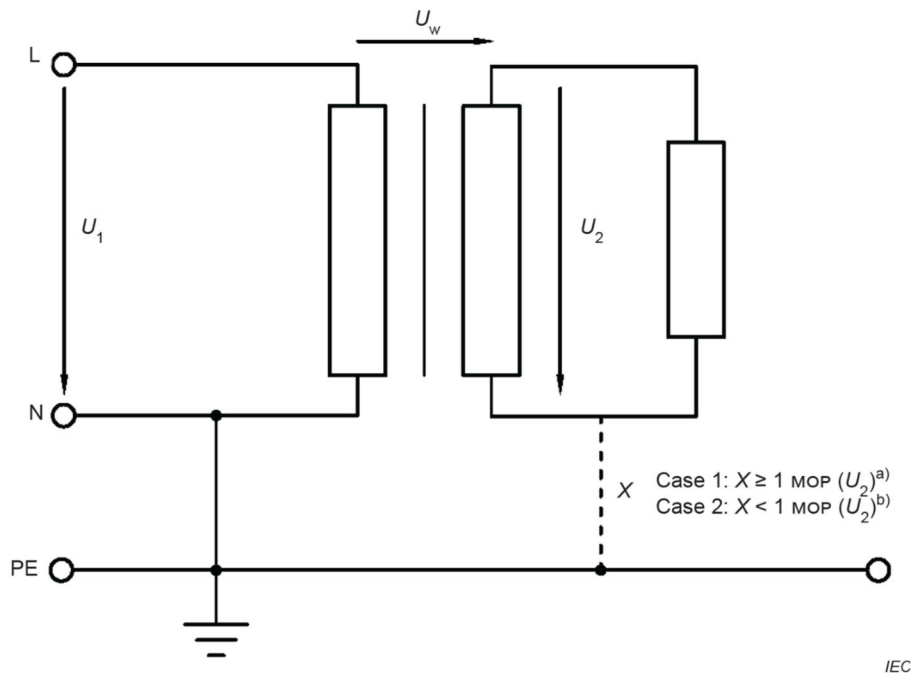

- a) For Case 1, the floating circuit is isolated from earth by 1 MOP based on the floating circuit voltage U_2 . The WORKING VOLTAGE (U_w) of the mains barrier is the highest voltage of one side of the barrier, i.e. U_1 or U_2 whichever is greater in magnitude.
- b) For Case 2, the floating circuit is not isolated by at least 1 MOP to earth based on the floating circuit voltage U_2 . For the measurement of the WORKING VOLTAGE (U_w) of the mains barrier both sides have to be earthed to obtain repeatable worst-case results.

Figure 41 – WORKING VOLTAGE measurement

8.5.5.1 * Defibrillation protection

Add, after the existing NOTE 2, modified by Amendment 1, the following text:

The differential-mode test shall not be performed on an APPLIED PART with multiple PATIENT CONNECTIONS if, based on the INTENDED USE, the PATIENT CONNECTIONS are intended to be completely within the body and in close proximity to each other where it can be assumed that they will all be at the same voltage potential when the PATIENT is defibrillated.

8.5.5.2 Energy reduction test

Add, after the existing first paragraph, the following text:

If the INTENDED USE of one APPLIED PART with multiple PATIENT CONNECTIONS that are all within close proximity to each other and completely within the body, these PATIENT CONNECTIONS are treated as a single PATIENT CONNECTION.

8.6.1 * Applicability of requirements

Replace, in the existing paragraph, the reference to "IEC 60950-1" with "IEC 60950-1:2005, IEC 60950-1:2005/AMD1:2009 and IEC 60950-1:2005/AMD2:2013 or IEC 62368-1:2018".

8.6.4 * Impedance and current-carrying capability

Replace the sixth paragraph of existing list item a), modified by Amendment 1, with:

Testing shall be carried out using a DETACHABLE POWER SUPPLY CORD as provided or specified (length and cross-sectional area) by the MANUFACTURER.

Add, after the existing ninth paragraph of list item a), modified by Amendment 1, the following text:

The highest RATED current is the RATED current of the over-current protection in the ME EQUIPMENT, when present, for all circuits located behind the over-current protection. From the SUPPLY MAINS to the over-current protection in the ME EQUIPMENT, the highest RATED current is the RATED current of the over-current protection device in the building installation.

NOTE When protective earth is relied on as a MEANS OF PROTECTION, the test current is determined based on the location where a fault could occur. If the prospective fault is in the mains supply circuit prior to the over-current protection included in the ME EQUIPMENT, the test current for that part of the protective earth circuit is based on the rating of the external over-current protection included in the building infrastructure or specified in the ACCOMPANYING DOCUMENTS (1,5 times the interrupt rating of the external over-current protection). If the prospective fault is in the mains supply circuit after the over-current protection included in the ME EQUIPMENT, the test current is based on the rating of the over-current protection included in the ME EQUIPMENT (1,5 times the interrupt rating of the ME EQUIPMENT over-current protection). In either case, the minimum test current is 25 A.

8.7.3 * Allowable values

Replace the existing list item e) with:

- e) Additionally, regardless of waveform and frequency, LEAKAGE CURRENT shall not exceed 10 mA r.m.s. in NORMAL CONDITION or in SINGLE FAULT CONDITION when measured with a non-frequency-weighted device, such as a measuring device similar to that shown in Figure 12 a) but without C_1 and R_1 .

8.7.4.2 * Measuring supply circuits

Replace the existing paragraph and NOTE, with:

- a) For ME EQUIPMENT specified for connection to a SUPPLY MAINS:

ME EQUIPMENT specified for connection to a SUPPLY MAINS is connected to an appropriate power source. For single-phase ME EQUIPMENT, the polarity of the supply is reversible and tests are conducted at both polarities.

NOTE 1 Figure F.1 to Figure F.5 (inclusive) show some suitable arrangements but do not cover all possibilities, for example, delta-connected 3-phase supplies. Refer to the IEC 60990 for additional types of arrangements.

- b) For INTERNALLY POWERED ME EQUIPMENT:

INTERNALLY POWERED ME EQUIPMENT is tested without any connection to a measuring supply circuit.

NOTE 2 For INTERNALLY POWERED ME EQUIPMENT, Figure 14 to Figure 20 (inclusive) do not use the isolation transformers T_1 or switches S_1 and S_5 . However, INTERNALLY POWERED ME EQUIPMENT that also has a means of connection to a SUPPLY MAINS shall also be tested according to a) above for that connection.

8.7.4.7 Measurement of the PATIENT LEAKAGE CURRENT

Replace, in the existing third paragraph of list item d), "parts involved." with "parts involved or if the RISK is acceptably low according to 8.5.2.2."

8.8.1 * General

Replace, in the existing third paragraph, the reference to "IEC 60950-1" with "IEC 60950-1:2005, IEC 60950-1:2005/AMD1:2009 and IEC 60950-1:2005/AMD2:2013 or IEC 62368-1".

Table 6 – Test voltages for solid insulation forming a MEANS OF PROTECTION

Replace, in the third to sixth columns of the ninth row of existing Table 6, modified by Amendment 1, " $1,06 \times U/\sqrt{2}$ " with " $1,06 \times U$ " (four occurrences).

Add the following table note to the end of existing Table 6, modified by Amendment 1:

NOTE 3 Insulation meeting the requirements for the test voltage for reinforced insulation for a nominal mains system voltage up to and including 250 V r.m.s according to IEC 62368-1:2018, Table 27 meets the requirements for 1 MOPP according to this table for a peak WORKING VOLTAGE up to 1 293 V. At higher WORKING VOLTAGES the insulation does not necessarily provide 1 MOPP.

Insulation meeting the requirements for the test voltage for reinforced insulation for a nominal mains system voltage above 250 V r.m.s. up to and including 600 V r.m.s. according to IEC 62368-1:2018, Table 27 meets the requirements for 1 MOPP according to this table for a peak WORKING VOLTAGE up to 2 172 V. At higher WORKING VOLTAGES the insulation does not necessarily provide 1 MOPP.

8.9.1.2 CREEPAGE DISTANCES and AIR CLEARANCES complying with IEC 60950-1

Replace the existing subclause and title modified by Amendment 1 with:

8.9.1.2 * CREEPAGE DISTANCES and AIR CLEARANCES complying with IEC 60950-1 or IEC 62368-1

Except as noted below, the values of Table 12 to Table 16 (inclusive) do not apply to CREEPAGE DISTANCES and AIR CLEARANCES forming MEANS OF OPERATOR PROTECTION that comply with the requirements of IEC 60950-1:2005, IEC 60950-1:2005/AMD1:2009 and IEC 60950-1:2005/AMD2:2013 or IEC 62368-1:2018 for INSULATION CO-ORDINATION and are used in the conditions (e.g. overvoltage category, pollution degree) under which compliance was tested.

Equipment/sub-assemblies/components complying with IEC 62368-1:2018 designed specifically for use with transient-free supply mains shall additionally comply with the applicable requirements of Table 13 to Table 16 (inclusive).

Table 8 – Multiplication factors for AIR CLEARANCES for altitudes up to 5 000 m

Replace, in the existing NOTE 1 in Table 8, the reference to "IEC 60950-1" with "IEC 60950-1:2005 and IEC 62368-1:2018".

8.9.1.12 SECONDARY CIRCUITS

Replace, in the first dash of the existing fifth paragraph, "voltage; and" with "voltage;".

Replace, in the second dash of the existing fifth paragraph, "...ME EQUIPMENT." with "...ME EQUIPMENT; or".

Add the following dash after the existing second dash of the fifth paragraph:

- the MEANS OF PROTECTION required by 15.4.3.5 and 15.5.1.1.

8.9.1.15 * CREEPAGE DISTANCES and AIR CLEARANCES for DEFIBRILLATION-PROOF APPLIED PARTS

Delete the existing NOTE, modified by Amendment 1.

Table 12 – Minimum CREEPAGE DISTANCES and AIR CLEARANCES providing MEANS OF PATIENT PROTECTION

Add the following table NOTES to the end of the existing table:

NOTE 1 For MOPP, the values of CREEPAGE DISTANCE and AIR CLEARANCE are based on values in the second edition of IEC 60601-1 [74] and are applied regardless of pollution degree, over-voltage category and material group.

NOTE 2 The CREEPAGE DISTANCE and AIR CLEARANCE in this table are both related to r.m.s. or d.c. WORKING VOLTAGES.

NOTE 3 It is recognised that the values in this table do not take into account waveforms with low r.m.s. and high PEAK WORKING VOLTAGES. For the specific case of switch mode power supply units employing MOPP, use the measured r.m.s. as the WORKING VOLTAGE.

NOTE 4 Barriers providing 2 MOOP according to Tables 13 to Table 15 (inclusive) or according to IEC 60950-1:2005, IEC 60950-1:2005/AMD1:2009 and IEC 60950-1:2005/AMD2:2013 meet the requirements for 1 MOPP according to this table for WORKING VOLTAGES up to and including 707 V d.c. / 500 V r.m.s. At higher WORKING VOLTAGES, 2 MOOP does not necessarily provide 1 MOPP.

Barriers providing REINFORCED INSULATION (2 MOOP) according to IEC 62368-1:2018 meet the requirements for 1 MOPP for WORKING VOLTAGES up to and including 354 V d.c. / 250 V r.m.s. according to this table. At higher WORKING VOLTAGES, REINFORCED INSULATION (2 MOOP) does not necessarily provide 1 MOPP.

Add, after following the existing Table 16 modified by Amendment 1, the following new subclause:

8.9.1.16 Conductive surface coatings

When conductive coatings are applied to non-metallic surfaces, it shall be established that flaking or peeling does not result in the reduction of any AIR CLEARANCE or CREEPAGE DISTANCE.

Compliance is checked by examination of the construction and of the available data. If such data is not available, compliance is checked by application of an appropriate coating test standard.

NOTE Example of coating test standards include ISO 2409 [78], ISO 4624 [79] and UL 746C [82].

8.9.2 * Application

Replace, in the existing list item b), "than 1 mm wide shall" with: "than the minimum spacing (X) shall".

8.9.4 * Measurement of CREEPAGE DISTANCES and AIR CLEARANCES

Replace, in the existing fifth paragraph, "1 mm" with "X mm".

Replace, in the existing sixth paragraph, "1 mm" with "X mm".

Replace, in the existing tenth paragraph, modified by Amendment 1, "1 mm" with "X mm".

Replace, in the existing eleventh paragraph, "1 mm" with "X mm".

Figure 23 – CREEPAGE DISTANCE and AIR CLEARANCE – Example 2

Replace, in the existing figure, modified by Amendment 1, "less than mm" by "less than X mm".

8.11.3.3 Cross-sectional area of POWER SUPPLY CORD conductors

Add the following sentence to the end of the existing first paragraph:

For ME EQUIPMENT utilizing POWER SUPPLY CORDS and operating at currents greater than 63 A, apply the electrical regulations appropriate for the jurisdiction in which the ME EQUIPMENT is to be used.

8.11.5 * Mains fuses and OVER-CURRENT RELEASES

Replace the existing third paragraph with:

Protective devices shall be of a breaking capacity based on the MANUFACTURER'S expectation of the highest branch circuit current and/or prospective short circuit current.

Delete the existing NOTE following the third paragraph.

9.2.1 * General

Replace the existing NOTE 2 added by Amendment 1 with:

NOTE 2 See ISO 14971:2019, subclauses 7.1 and 7.4.

9.4.2.3 Instability from horizontal and vertical forces

Replace, in the first paragraph of existing item a) modified by Amendment 1, "safety sign" with "SAFETY SIGN" in two places.

Replace, in the first paragraph of existing item b) modified by Amendment 1, "safety signs" with "SAFETY SIGNS" in two places.

9.4.3.1 Instability in transport position

Replace, in the existing first line of third paragraph of list item c), "9.4.2.2" with "9.4.2.1".

9.6.2.1 Audible acoustic energy

Add, after the existing NOTE 3 modified by Amendment 1, the following NOTE:

NOTE 4 Acoustic energy directly associated with the INTENDED USE of the ME EQUIPMENT or ME SYSTEMS is excluded. See subclauses 1.1 and 7.2.13.

9.7.3 Maximum pressure

Replace the existing subclause title with "9.7.3 Void" and delete the subclause text.

9.7.4 Pressure rating of ME EQUIPMENT parts

Replace the existing first paragraph with:

The MAXIMUM EQUIPMENT PRESSURE shall not exceed the MAXIMUM PERMISSIBLE WORKING PRESSURE for the part, except as allowed for pressure relief devices in 9.7.7.

9.7.5 * Pressure vessels

Replace, in the existing two dashes of the first paragraph, "pressure" with "MAXIMUM EQUIPMENT PRESSURE".

Replace, in the existing third and fourth paragraphs, "MAXIMUM PERMISSIBLE WORKING PRESSURE" with "MAXIMUM EQUIPMENT PRESSURE".

Figure 32 – Ratio between HYDRAULIC TEST PRESSURE and MAXIMUM PERMISSIBLE WORKING PRESSURE (see 9.7.5)

Replace the existing figure and title with:

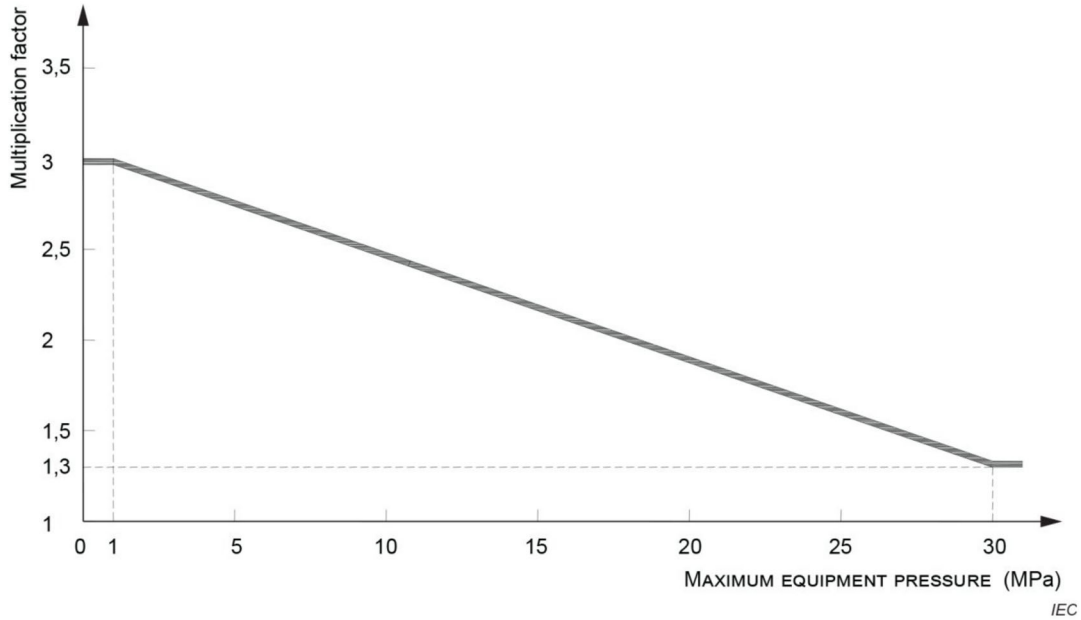

Figure 32 – Ratio between HYDRAULIC TEST PRESSURE and MAXIMUM EQUIPMENT PRESSURE (see 9.7.5)

9.7.6 Pressure-control device

Add, after the existing second paragraph modified by Amendment 1, the following NOTE:

NOTE When applicable, ISO 10524-1:2018 [80] can be a suitable component standard (see 4.8).

9.7.7 Pressure-relief device

Replace, in the existing list item f), "MAXIMUM PERMISSIBLE WORKING PRESSURE" with "MAXIMUM EQUIPMENT PRESSURE".

Table 21 – Determination of TENSILE SAFETY FACTOR

Replace, in the existing table, the seventh row with:

| | | | | |
|---|---|---|-----|---|
| 7 | MECHANICAL PROTECTIVE DEVICE (or back-up system of multiple support system) | Metallic material ^d having a specific elongation at break equal to or greater than 5 % is assumed (see rationale in Annex A, subclause 9.8.4). | 2,5 | 4 |
|---|---|---|-----|---|

9.8.3.3 * Dynamic forces due to loading from persons

Replace, in the existing fourth paragraph, modified by Amendment 1, the next to last sentence with:

The body upper-carriage module with appropriate mass is dropped from a distance of 150 mm from the lowest edge of the foam to the area where a PATIENT or OPERATOR can sit.

9.8.4.3 MECHANICAL PROTECTIVE DEVICE intended for single activation

Replace, in the existing third dash modified by Amendment 1, "safety sign" with "SAFETY SIGN" in two places.

10.1.1 * ME EQUIPMENT not intended to produce diagnostic or therapeutic X-radiation

Replace the existing NOTE 3 modified by Amendment 1 with:

NOTE 3 This test PROCEDURE is equivalent to that in IEC 60950-1:2005, Annex H or to IEC 62368-1:2018, 10.5.3.

10.4 * Lasers

Replace, in the existing first paragraph, modified by Amendment 1, "For lasers that produce" with "For lasers, including laser diodes, that produce" and replace "IEC 60825-1:2007" with "IEC 60825-1:2014".

Replace, in the existing NOTE added by Amendment 1, the reference to "IEC 60825-1" with "IEC 60825-1:2014".

Replace, in the existing second paragraph, modified by Amendment 1, "IEC 60825-1:2007" with "IEC 60825-1:2014".

10.5 Other visible electromagnetic radiation

Add an asterisk () at the beginning of the subclause title, and delete, in the existing first paragraph, "and light emitting diodes".*

10.6 Infrared radiation

Add an asterisk () at the beginning of the subclause title, and delete, in the existing first paragraph, "and light emitting diodes".*

10.7 Ultraviolet radiation

Add an asterisk () at the beginning of the subclause title, and delete, in the existing first paragraph, "and light emitting diodes".*

11.1.1 * Maximum temperature during NORMAL USE

Add, after the existing first dash, the following NOTE:

NOTE Also see the information in 13.1.2 when applying SINGLE FAULT CONDITIONS.

Table 23 – Allowable maximum temperatures for ME EQUIPMENT parts that are likely to be touched

Replace the title of the existing table with the following new title:

Table 23 – Allowable maximum temperatures for ACCESSIBLE PARTS that are likely to be touched

Replace, in the first column, first row of the existing table, "ME EQUIPMENT and its parts" with "ACCESSIBLE PARTS".

Replace, in the first column, second row of the existing table, "ME EQUIPMENT" with "ACCESSIBLE PARTS".

11.1.3 * Measurements

Replace, in the first line of the existing second paragraph, "ME EQUIPMENT parts" with "ACCESSIBLE PARTS".

11.3 * Constructional requirements for fire ENCLOSURES of ME EQUIPMENT

Replace the existing first paragraph of list item a) with:

- a) Insulated wire and connectors within the fire ENCLOSURE shall have a flammability classification of minimum V-2 when tested in accordance with IEC 60695-11-10, or be insulated with PVC, TFE, PTFE, FEP, polychloroprene or polyimide.

Printed circuit boards and insulating material on which components are mounted shall have a flammability classification of V-2, or better, according to IEC 60695-11-10.

Replace, in the existing second paragraph of list item a), "FV tests" with "V tests".

Replace the existing elements 1) and 2) of list item b) with:

- 1) The bottom shall:
 - have no openings; or
 - to the extent specified in Figure 39, shall be constructed with baffles as specified in Figure 38; or
 - be made of metal, perforated as specified in Table 25; or
 - be a metal screen with a mesh not exceeding 2 mm × 2 mm centre to centre and a wire diameter of at least 0,45 mm.
- 2) The sides within the area that is included within the inclined line C in Figure 39 shall:
 - have no openings; or
 - be made of metal, perforated as specified in Table 25; or
 - be a metal screen with a mesh not exceeding 2 mm × 2 mm centre to centre and a wire diameter of at least 0,45 mm.

Replace, in the existing first paragraph of element 3) of list item b), "FV-2" with "V-2" and "FV-1" with "V-1".

Add, after the existing second paragraph of element 3) of list item b), the following NOTE:

NOTE Other design solutions for openings in the fire ENCLOSURE (e.g. baffle solutions) could be acceptable, like solutions provided in other standards. See first paragraph of 11.3 with respect to RISK MANAGEMENT.

11.6.5 * Ingress of water or particulate matter into ME EQUIPMENT and ME SYSTEMS

Replace, in the existing third paragraph modified by Amendment 1, "After these PROCEDURES" with "After the tests of IEC 60529".

12.2 USABILITY of ME EQUIPMENT

Replace, in the existing first and second paragraphs, modified by Amendment 1, the reference to "IEC 60601-1-6" with "IEC 60601-1-6:2010, IEC 60601-1-6:2010/AMD1:2013 and IEC 60601-1-6:2010/AMD2:2020".

12.3 ALARM SYSTEMS

Replace, in the existing first and second paragraphs, modified by Amendment 1, the reference to "IEC 60601-1-8" with "IEC 60601-1-8:2006, IEC 60601-1-8:2006/AMD1:2012 and IEC 60601-1-8:2006/AMD2:2020".

13.1.2 * Emissions, deformation of ENCLOSURE or exceeding maximum temperature

Replace the existing fourth dash with:

- * temperatures of ACCESSIBLE PARTS that are likely to be touched, but not intended to be touched to operate the ME EQUIPMENT, exceeding the limits in Table 34 when measured and adjusted as described in 11.1.3;
- * temperatures of ACCESSIBLE PARTS, intended to be touched to operate the ME EQUIPMENT, exceeding the limits in Table 23;

Add, after the existing second paragraph, the following new table:

Table 34 – Allowable maximum temperatures for ACCESSIBLE PARTS that are likely to be touched, but not intended to be touched to operate the ME EQUIPMENT

| ME EQUIPMENT and its parts | Maximum temperature °C | | | |
|--|---------------------------|-------------------------------------|-----------------------------------|------|
| | Metal and liquids | Glass, porcelain, vitreous material | Moulded material, plastic, rubber | Wood |
| External surfaces of ACCESSIBLE PARTS that are likely to be touched for a time $t < 1$ s | 80 | 90 | 104 | 150 |

Add, after the existing sixth dash, modified by Amendment 1, the following NOTE:

NOTE 1 When the investigated part of the supply circuit is a battery, the limit for the power dissipation is considered directly on the output contacts of the battery supply circuit, even before an external protective device.

Replace, in the existing first bulleted item of the seventh dash, modified by Amendment 1, "FV1" with "V-1".

Replace, in the existing second bulleted item in the seventh dash, modified by Amendment 1, "42,2 V peak" with "42,4 V peak".

Replace the existing third bulleted item in the seventh dash, modified by Amendment 1, with:

- they are limited to less than 100 VA or are limited to less than 6 000 J in SINGLE FAULT CONDITION;

Add, before the compliance paragraph following the seventh dash, modified by Amendment 1, the following NOTE:

NOTE 2 When the investigated part of the supply circuit is a battery, the limit for the power dissipation is considered directly on the output contacts of the battery supply circuit, even before an external protective device.

Replace the compliance paragraph following the seventh dash, modified by Amendment 1, with:

Compliance is checked by the following:

- by drawing 100 VA from the supply circuit for 5 s after application of the load if protection is by an electronic circuit;
- by drawing 100 VA from the supply circuit for 60 s for a positive temperature coefficient device, or in other cases.

If, after the specified time above, the supply circuit cannot supply 100 VA, the circuit shall be considered to limit power dissipation to less than 100 VA. The related design documentation is also reviewed.

Renumber the existing NOTE as NOTE 3.

13.1.3 Exceeding LEAKAGE CURRENT or voltage limits

Replace, in the existing second dash, "including APPLIED PARTS" with "and APPLIED PARTS".

13.2.1 General

Add, after the existing first paragraph, the following text:

If resistance to heat for insulation of thermoplastic materials that is used as SUPPLEMENTARY INSULATION or REINFORCED INSULATION is established by performing the ball-pressure test in 8.8.4.1, the test is performed at a temperature 25 °C higher than the temperature of the insulation measured during the tests of 13.2.2 to 13.2.13 (inclusive).

13.2.8 Locking of moving parts

Replace, in the existing first dash, "including APPLIED PARTS" with "or APPLIED PARTS".

13.2.13.1 * General overload test conditions

Delete the existing third paragraph.

14.1 * General

Replace, in existing NOTE 2, modified by Amendment 1, "PEES" with "PESS" in two places.

Replace, in existing NOTE 3, modified by Amendment 1, the third sentence with:

SOUP is defined in IEC 62304:2006/AMD1:2015 as a "software item that is already developed and generally available and that has not been developed for the purpose of being incorporated into the medical device (also known as 'off-the-shelf software') or software item previously developed for which adequate RECORDS of the development PROCESSES are not available".

Replace, in the existing fourth paragraph, modified by Amendment 1, "subclause 4.3" with "subclauses 4.3 and 4.4" and replace "IEC 62304:2006" with "IEC 62304:2006 and IEC 62304:2006/AMD1:2015".

Replace, in the existing fifth paragraph and NOTE 5, modified by Amendment 1, "IEC 62304:2006" with "IEC 62304:2006 and IEC 62304:2006/AMD1:2015".

14.4 * PEMS DEVELOPMENT LIFE-CYCLE

Replace, in the existing sixth paragraph, "activities, milestones and schedules" with "activities and milestones".

14.6.1 * Identification of known and foreseeable HAZARDS

Replace, in the existing NOTE, modified by Amendment 1, "Annex E of ISO 14971:2007" with "Annex C of ISO 14971:2019".

14.12 * Modification

Replace, in the existing second paragraph, modified by Amendment 1, "subclause 4.3" with "subclauses 4.3 and 4.4" and "IEC 62304:2006" with "IEC 62304:2006 and IEC 62304:2006/AMD1:2015".

15 Construction of ME EQUIPMENT

15.1 * Arrangements of controls and indicators of ME EQUIPMENT

Replace, in the existing second paragraph, modified by Amendment 1, the reference to "IEC 60601-1-6" with "IEC 60601-1-6:2010, IEC 60601-1-6:2010/AMD1:2013 and IEC 60601-1-6:2010/AMD2:2020".

15.3.4.1 HAND-HELD ME EQUIPMENT

Replace, in the existing third paragraph, modified by Amendment 1, "(hardwood > 600 kg/m³)" with "(for example, hardwood density > 600 kg/m³)".

15.3.4.2 * PORTABLE ME EQUIPMENT

Replace, in the existing third paragraph, "(for example, > 600 kg/m³)" with "(for example, hardwood density > 600 kg/m³)".

15.3.5 * Rough handling test

Replace, in the existing list item a), modified by Amendment 1, "40 mm" with "40 mm ± 2 mm". (2 places).

Replace, in the existing first paragraph of list item b), modified by Amendment 1, "40 mm" with "40 mm ± 2 mm".

Replace, in the existing list item c), modified by Amendment 1, "40 mm" with "40 mm ± 2 mm".

15.4.3.4 Lithium batteries

Replace, in the existing first and second paragraphs, modified by Amendment 1, "IEC 62133" with "IEC 62133 or IEC 62133-2".

16.2 * ACCOMPANYING DOCUMENTS of an ME SYSTEM

Replace, in the existing list item a), "(see 7.8.2)" with "(see 7.9)".

Add, in the existing first dash of list item d), a comma following "adjustment".

16.9.2.1 * MULTIPLE SOCKET-OUTLET

Replace, in the first dash of the existing item b), "safety sign" with "SAFETY SIGN" in two places.

16.9.2.2 * PROTECTIVE EARTH CONNECTIONS in ME SYSTEMS

Replace, in the existing first paragraph, modified by Amendment 1, "MAINS CONNECTION" with "SUPPLY MAINS connection".

Replace the second sentence of the existing first paragraph, modified by Amendment 1, with:

Where the pathway of a fault current caused by a live part to a PROTECTIVE EARTHED part is protected only by the SUPPLY MAINS circuit over-current release (e.g. circuit breaker or fuse), the protective earth resistance of that pathway shall not exceed 200 mΩ.

Insert after the existing first paragraph, the following text:

Where the pathway of a fault current caused by a live part to a PROTECTIVE EARTHED part is protected by additional intermediate circuit breakers or fuses with current ratings 13 A or lower, then compliance with 8.6.4 b) and 8.7.2, first dash, is achieved and the protective earth resistance to that part of the fault pathway may exceed 200 mΩ but shall be less than 400 mΩ.

17 * Electromagnetic compatibility of ME EQUIPMENT and ME SYSTEMS

Replace the existing text of this clause with:

The MANUFACTURER shall address the RISK(S) associated with ELECTROMAGNETIC DISTURBANCES.

Compliance is checked as specified in IEC 60601-1-2:2014 and IEC 60601-1-2:2014/AMD1:2020.

Annex A – General guidance and rationale

A.4 Rationale for particular clauses and subclauses

Subclause 1.3 – Collateral standards

Delete, in the existing second dash, the second sentence beginning with "At the time of publication....".

Delete the existing second and third paragraphs.

Subclause 3.40 – HAZARDOUS SITUATION

Replace the parenthetical expression at the end of the existing paragraph with "(see Figure A.8 adapted from Figure C.1 of ISO 14971:2019)".

Figure A.8 – Pictorial representation of the relationship of HAZARD, sequence of events, HAZARDOUS SITUATION and HARM

Replace the existing figure with the following new figure:

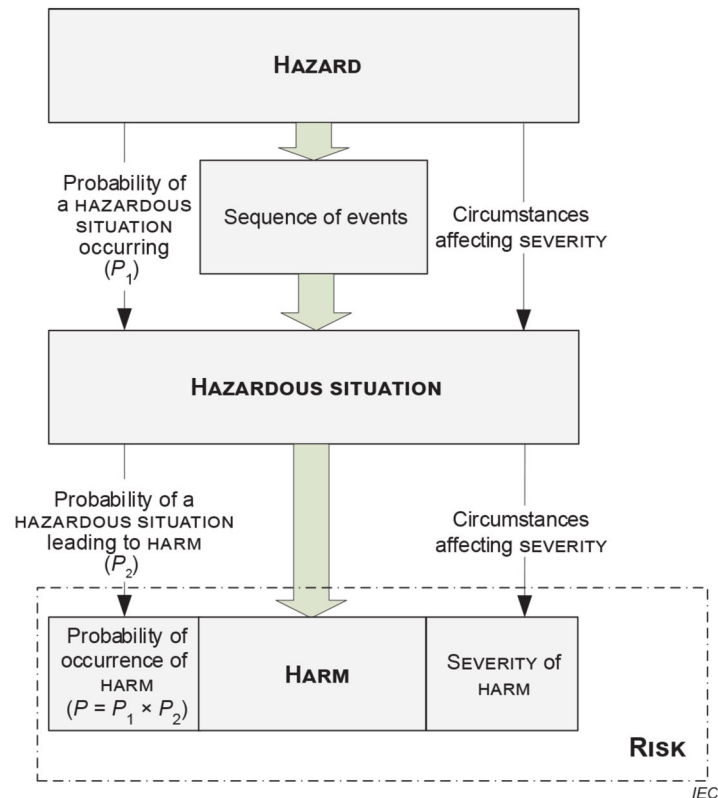

NOTE 1 Depending on the complexity of the ME EQUIPMENT or ME SYSTEM, a HAZARD can lead to multiple HAZARDOUS SITUATIONS, and each HAZARDOUS SITUATION can lead to multiple HARMs.

NOTE 2 The probability of occurrence of HARM (P) can be composed of separate P_1 and P_2 values.

NOTE 3 The thin arrows represent elements of RISK ANALYSIS and the thick arrows depict how a HAZARD can lead to HARM.

Figure A.8 – Illustration of the relationship of HAZARD, sequence of events, HAZARDOUS SITUATION and HARM

Subclause 3.44 –

Delete the subclause title, modified by Amendment 1.

Subclause 3.58 – MEANS OF PROTECTION

Replace, in the existing subclause title, "3.58" with "3.60".

Subclause 3.60 – MEANS OF OPERATOR PROTECTION

Replace in the existing subclause title, "3.60" with "3.58".

Place the modified subclause titles 3.58 and 3.60 in their new numbering order.

Subclause 3.78 – PATIENT CONNECTION

Replace, in the existing final paragraph, "8.7.4.7 d)" with "8.7.4.7 e)".

Subclause 3.139 – WORKING VOLTAGE

Add, after the rationale for Subclause 3.139, the following new rationales:

Subclause 3.150 – INFORMATION SIGNAL

ALARM SIGNALS are only generated because of the presence of an ALARM CONDITION. In contrast, INFORMATION SIGNALS are those that are generated regardless of whether or not an ALARM CONDITION is present. The waveform of a physiological signal and the associated numeric are considered INFORMATION SIGNALS as they are independent of ALARM CONDITIONS. INFORMATION SIGNALS can frequently convey information that is “alarming” to the OPERATOR but are not, in and of themselves an ALARM SIGNAL.

EXAMPLE 1 The decreasing tonal frequency of the auditory INFORMATION SIGNAL of some pulse oximeters. The decreased tone is “alarming” to the OPERATOR, but in itself is not an ALARM SIGNAL.

EXAMPLE 2 An electrocardiograph waveform indicating ventricular fibrillation.

EXAMPLE 3 A heart rate of 20 beats/min.

Subclause 3.152 – MAXIMUM EQUIPMENT PRESSURE

The maximum pressure to which a part of ME EQUIPMENT can be subjected in NORMAL CONDITION and SINGLE FAULT CONDITION is determined by analysis and where needed, measurements. Traditionally it has been considered to be whichever is the highest of the following:

- the RATED maximum supply pressure from an external source;
- the pressure setting of a pressure-relief device provided as part of the assembly; or
- the maximum pressure that can be developed by a source of pressure that is part of the assembly, unless the pressure is limited by a pressure-relief device.

The RATED maximum supply pressure is marked on the ME EQUIPMENT (7.2.18). If the maximum source pressure rating is based on a regulator at supply, consider failure of the regulator. MAXIMUM EQUIPMENT PRESSURE might be that of the rating of regulator at the pressure input connector of the ME EQUIPMENT (or specified as required during installation), or the rating of the pressure relief device provided within the ME EQUIPMENT. Pressure (or vacuum) systems will typically directly control pressure (or vacuum) with a pressure regulator and a pressure relief device. The single-fault pressure becomes the relief device pressure (failed regulator). Electronics (or electromechanical circuits) could indirectly regulate pressure (or vacuum). If pressure is from a pump or compressor, there could be regulation provided by motor drive from power convertor or inverter system. If pressure is from a heat source, then consider faults to electronic ignition or temperature control system. Typically a pressure relief device would provide pressure limiting backup to electronic or electromechanical faults. In any case, the MAXIMUM EQUIPMENT PRESSURE in SINGLE FAULT CONDITION needs to be considered.

When considering the HAZARDOUS SITUATION that overpressure (or underpressure) can present, the concern is the bursting/rupture (or implosion) of a part could lead to HARM. The gauge pressure speaks to the bursting (or implosion) HAZARDOUS SITUATION most directly since it is the difference between internal absolute pressure and outside absolute pressure. The hydraulic test on pressure vessels in 9.7.5 is based on the maximum equipment gauge pressure. Pressure components are normally rated with a gauge pressure (e.g. kPaG). An absolute pressure rating could be translated to a gauge pressure rating:

Gauge pressure = inside absolute pressure – outside (e.g. atmospheric) absolute pressure.

ME EQUIPMENT MANUFACTURERS are required to specify intended ranges for absolute air pressure (temperature, and humidity) for modes, transport and storage, and operating. With home care equipment, the additional mode of transport and storage between uses needs to be specified. Subclause 7.2.17 requires these ranges on shipping containers, and 7.9.3.1 requires them in the technical description that users receive. This gives persons the environmental ranges that designers considered when selecting pressure components.

Subclause 4.2 – RISK MANAGEMENT PROCESS for ME EQUIPMENT or ME SYSTEMS

Replace, in the existing third paragraph, modified by Amendment 1, "ISO 14971:2007" with "ISO 14971:2019" in two places.

Replace, in the existing sixth dash (RISK EVALUATION), modified by Amendment 1, "subclause 6.3 of ISO 14971:2007" with " subclause 7.2 of ISO 14971:2019".

Replace, in the existing final dash (RISK/benefit analysis), modified by Amendment 1, "Risk/benefit" with "Benefit-RISK", "RISK/benefit" with "benefit-RISK" in two places and "subclause 6.5 of ISO 14971:2007" with "subclause 7.4 of ISO 14971:2019".

Subclause 4.5 – Alternative RISK CONTROL measures or test methods for ME EQUIPMENT or ME SYSTEMS

Add, after the existing third paragraph, modified by Amendment 1, the following text:

With Amendment 2, the application of the INSULATION CO-ORDINATION requirements in IEC 62368-1:2018 can be used as a MEANS OF OPERATOR PROTECTION (MOOP) for sub-assemblies/components that are built into ME EQUIPMENT. However, not all of the requirements for OPERATOR protection in IEC 62368-1:2018 have been integrated in Amendment 2. Only Clause 8 and one note in Clause 10 have been addressed. For the remainder of this document, the safety solutions in IEC 62368-1:2018 have not been taken into account in Amendment 2. These will be addressed during the development of the fourth edition of this document.

For IEC 62368-1:2018 certified sub-assemblies/components that are built into ME EQUIPMENT, Clause 7 and Clauses 9 to 15 (inclusive) of this standard are applied as stated. If a requirement in IEC 62368-1:2018 is related to OPERATOR safety and is in conflict with parts of Clause 7 and Clauses 9 to 15 (inclusive), it can be evaluated according to the detailed requirements of 4.5.

In all cases, the requirements for MEANS OF PATIENT PROTECTION (MOPP) in this standard still need to be applied.

Subclause 6.3 – Protection against harmful ingress of water or particulate matter

Delete the existing title and text.

Subclause 7.2.3 – Consult ACCOMPANYING DOCUMENTS

Replace the existing paragraph, modified by Amendment 1, with:

During the RISK MANAGEMENT PROCESS of a ME EQUIPMENT, if the MANUFACTURER determines that reading information within the instructions for use is a mandatory action necessary to control a specific RISK to an acceptable level, then the SAFETY SIGN ISO 7010-M002 (2011-05) (see Table D.2, SAFETY SIGN 10) notifies the OPERATOR of that need. In other words, if the means for an OPERATOR to avoid a specific and unacceptable RISK is only reading (and understanding) the instructions for use, then the SAFETY SIGN is required. If the OPERATOR does not read (and understand) those instructions for use, the RISK CONTROL is ineffective and there is an unacceptable RISK.

The SAFETY SIGN ISO 7010-M002 should not be used for indicating that it is a mandatory action to read the instructions for use for the disclosure of RESIDUAL RISK.

The MANUFACTURER should use the USABILITY ENGINEERING PROCESS to determine whether or not using SAFETY SIGN ISO 7010-M002 as an effective means to control RISK to an acceptable level. The SAFETY SIGN should be placed in a location that is visible from the intended position of the OPERATOR.

It is not intended in every case when the instructions for use contain warnings, that the ME EQUIPMENT be marked with ISO 7010-M002 (i.e. instructions for use are not used as the primary RISK CONTROL measure). Symbol ISO 7000-1641 (2004-01) (see Table D.1, symbol 11) is used to indicate that the instructions for use should be considered when operating the ME EQUIPMENT. The symbol should be placed in a location close to a control needing reference to the instructions for use. This symbol can also be used to identify the location where the instructions for use is stored.

Subclause 7.3.2 – HIGH VOLTAGE parts

Replace, in the existing first paragraph, modified by Amendment 1, "(see Table D.3. safety sign 3)" with "(see Table D.2. SAFETY SIGN 3)", and in the final sentence, "safety sign" with "SAFETY SIGN".

Subclause 7.4.2 – Control devices

Replace, in the existing second paragraph, "IEC 60950-1" with "IEC 60950-1:2005".

Subclause 7.8 – Indicator lights and controls

Add, after the existing second paragraph, added by Amendment 1, the following text and the following new rationale:

INFORMATION SIGNALS, such as a waveform or a parameter numeric, are allowed to use any colour, including red, yellow, cyan, and green, as long as they are correctly perceived as different from HIGH, MEDIUM and LOW PRIORITY alarm indicator lights and as different from red, yellow, and green indicator lights.

Subclause 7.8.1 – Colour of indicator lights

It is important to distinguish HIGH PRIORITY, MEDIUM PRIORITY and LOW PRIORITY ALARM SIGNALS from the warning and caution signals. A warning signal, a steady (constant, non-flashing) red light, and the caution signal, a steady (constant, non-flashing) yellow light, are to be used for conditions that are present in NORMAL USE. The warning signal alerts the OPERATOR to a HAZARDOUS SITUATION that can cause death or serious injury. The caution signal alerts the OPERATOR to a HAZARDOUS SITUATION that can cause minor or moderate injury or ME EQUIPMENT damage. Thus, these signals are akin to SAFETY SIGNS or markings that indicate warnings and cautions at all times. Typically, these indicator lights would be accompanied by natural language that explains the HAZARD or a HAZARDOUS SITUATION. An example might be a warning or caution light to signify a hot surface that should not be touched, or the danger of opening a door and risking exposure to radiation. In these examples, the hot surface and the radiation are expected to be present during NORMAL USE. Warning and caution lights do not require OPERATOR action (as a HIGH PRIORITY or MEDIUM PRIORITY ALARM SIGNAL requires), and they do not require a change in workflow; they merely require awareness. Furthermore, warning and caution lights are considered INFORMATION SIGNALS and are not accompanied by ALARM SIGNALS.

On the other hand, HIGH PRIORITY ALARM SIGNALS can include an alarm indicator light (a flashing red light as opposed to a steady red light) and can be accompanied by an appropriate auditory ALARM SIGNAL. Similarly, a MEDIUM PRIORITY ALARM SIGNAL can include an alarm indicator light (a flashing yellow light as opposed to a steady yellow light) and can be accompanied by an appropriate auditory ALARM SIGNAL. In either case, OPERATOR action and changes in workflow are required.

Clause 8 – Protection against electrical HAZARDS from ME EQUIPMENT

Replace, in the existing list item b), "including APPLIED PARTS" with "and APPLIED PARTS".

Replace, in the existing list item c), "...including APPLIED PARTS..." with "...and APPLIED PARTS...".

Subclause 8.1 a)

Replace, in the existing first paragraph, "...including APPLIED PARTS." with "...and APPLIED PARTS".

Subclause 8.1 b)

Replace, in the existing third paragraph, "...including APPLIED PARTS," with "...and APPLIED PARTS,".

Subclause 8.4.2 – ACCESSIBLE PARTS including APPLIED PARTS

Replace, in the subclause title, "including" with "and".

Subclause 8.4.2 c)

Replace, in the existing first paragraph, modified by Amendment 1, the second reference to "IEC 60950-1" with "IEC 60950-1:2005".

Replace, in the existing second paragraph, modified by Amendment 1, the first reference to "IEC 60950-1" with "IEC 60950-1:2005", and the reference to "IEC 60950" with "IEC 60950-1".

Subclause 8.4.3 – ME EQUIPMENT intended to be connected to a power source by a plug

Replace, in the existing paragraph, "IEC 60479-1 [11]" with "IEC 60479-1 [73]".

Subclause 8.5.1 – MEANS OF PROTECTION

Replace, in the existing tenth paragraph starting with "However the test voltages", the first reference to "IEC 60950-1" with "IEC 60950-1:2005, IEC 60950-1:2005/AMD1:2009 and IEC 60950-1:2005/AMD2:2013".

Replace, in the existing penultimate paragraph, "(see Figure A.12)" with "(see Figure 40)".

Add, after the existing penultimate paragraph, the following new text, new table and new figures:

Amendment 2 has expanded the options for MEANS OF OPERATOR PROTECTION to include the application of the requirements of IEC 62368-1:2018, which is replacing IEC 60950-1.

Based on a detailed review of the difference in the requirements of IEC 62368-1:2018, IEC 60950-1:2005, IEC 60950-1:2005/AMD1:2009 and IEC 60950-1:2005/AMD2:2013 and this document, it was determined that for MOOP IEC 62368-1:2018 can be used directly as an alternative to IEC 60950-1:2005, IEC 60950-1:2005/AMD1:2009 and IEC 60950-1:2005/AMD2:2013. There are limitations identified where necessary within the normative text to clarify differences between this standard and IEC 62368-1:2018 when barriers providing 2 MOOP are additionally relied on to provide 1 MOPP.

During the review process, it was determined that there are two typical scenarios for how equipment complying with IEC 62368-1:2018 might be incorporated into ME EQUIPMENT. These scenarios are described below in Table A.6. See also Clause 16 for information on the use of equipment complying with IEC 62368-1:2018 as part of an ME SYSTEMS.

Table A.6 – Typical scenarios for the use of equipment complying with IEC 62368-1:2018 in ME EQUIPMENT

| Scenario | Description | Examples |
|----------|---|---|
| 1 | Sub-assemblies/components complying with IEC 62368-1:2018 are built into ME EQUIPMENT. In this scenario, sub-assemblies/components complying with IEC 62368-1:2018 are fully contained within the ENCLOSURE of the ME EQUIPMENT and are accessible only with the use of a tool (the output parts of the power supply or AC-DC connectors can be accessible at SIP/SOP connections without the use of a tool). Sub-assemblies/component complying with IEC 62368-1:2018 are generally considered as a sub-assembly/component of the ME EQUIPMENT and they cannot be used separately. | Internal power supplies, optical disc drives, transformers, processor circuit board assemblies, DC-DC converters, AC-DC converters, Bluetooth communication modules |
| 2 | Equipment/sub-assemblies complying with IEC 62368-1:2018 are provided as a part of ME EQUIPMENT, but are not built into the ME EQUIPMENT and are readily accessible to the OPERATOR and/or PATIENT. Equipment/sub-assemblies complying with IEC 62368-1:2018 are provided with their own ENCLOSURE and can be used separately from the ME EQUIPMENT. | External/Stand-alone power supplies, computers, monitors, printers, keyboards |

NOTE See Figure A.24 and Figure A.25 for pictorial representations of Scenarios 1 and 2.

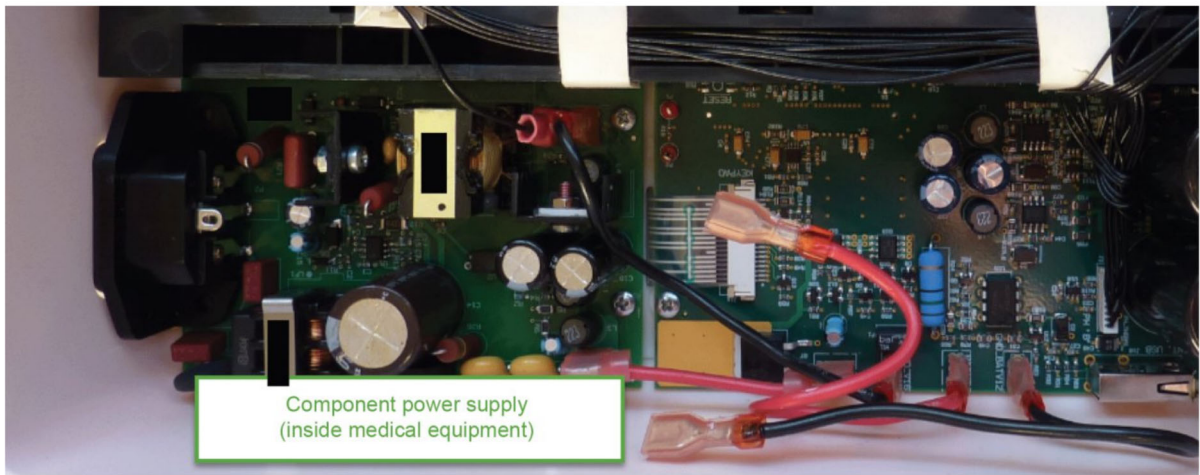

IEC

Figure A.24 – Example of Scenario 1

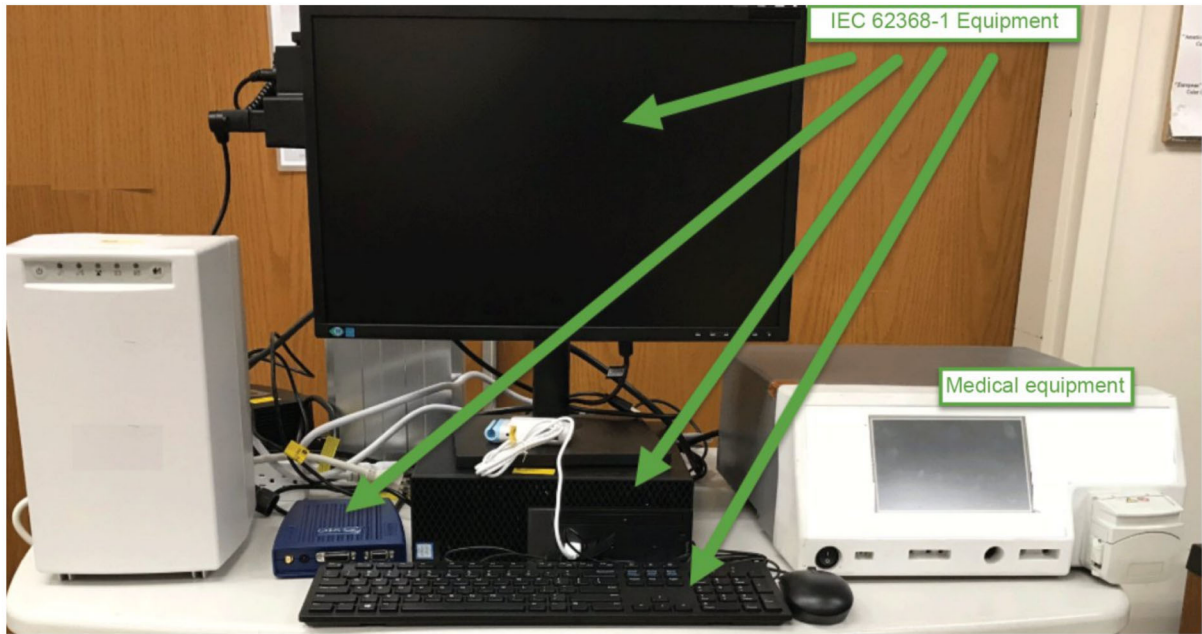

Figure A.25 – Example of Scenario 2

The analysis focused on these scenarios. The purpose was to determine if any differences in the application of requirements of IEC 62368-1:2018 would be necessary based on the use scenario.

Where IEC 62368-1:2018 has been identified as an acceptable alternative to the requirements of this standard or IEC 60950-1:2005, IEC 60950-1:2005/AMD1:2009 and IEC 60950-1:2005/AMD2:2013, no additional rationale has been written.

During the review process, some differences in terminology were identified between this standard and IEC 62368-1:2018. Specifically, the definitions for TOUCH CURRENT and PEAK WORKING VOLTAGE were reviewed; while differences were noted, it was determined that these differences did not have any technical effect on the use of IEC 62368-1:2018 as identified in the body of this document.

Figure A.12 – Identification of MEANS OF PATIENT PROTECTION and MEANS OF OPERATOR PROTECTION

Delete the existing Figure A.12, modified by Amendment 1.

Subclause 8.5.1.2 – MEANS OF PATIENT PROTECTION (MOPP)

Replace the existing text of this paragraph, modified by Amendment 1, with the following:

CREEPAGE DISTANCES:

A detailed review of the requirements for CREEPAGE DISTANCES from IEC 62368-1:2018, IEC 60950-1:2005 and this standard confirmed that there were no significant changes in the requirements and that 2 MOOP according to IEC 62368-1:2018 will provide 1 MOPP according to this document.

When determining creepage distances according to IEC 62368-1:2018, the largest value from IEC 62368-1:2018, Table 17 or Table 18 is always applied. This is clarified in the text at the bottom of IEC 62368-1:2018, Table 17.

AIR CLEARANCE:

Table 13 and Table 14 were reviewed to determine where barriers providing 2 MOOP would also satisfy the requirements for 1 MOPP from Table 12. Based on historical discussions, it has been assumed that 2 MOOP would always also meet the requirements for 1 MOPP with respect to AIR CLEARANCE requirements; however, limitations were identified which led to the addition of NOTE 4 in Table 12.

IEC 60950-1:2005, Table 2K and Table 2L and IEC 62368-1:2018, Table 10 to Table 15 (inclusive) were evaluated for the same purpose and compared to Table 12.

This review of the requirements for AIR CLEARANCE between Table 12, IEC 60950-1:2005, Table 2K and Table 2L and IEC 62368-1:2018, Table 10 to Table 14 (inclusive) identified limitations for when 2 MOOP would provide 1 MOPP. This is important when evaluating separation from the SUPPLY MAINS (typically provided by a switch mode power supply or similar component) since a barrier providing 2 MOOP will not always provide 1 MOPP as currently required by this document. Additional information and examples are provided below.

Table 13 is copied from IEC 60950-1:2005, Table 2K; Table 14 is copied from IEC 60950-1:2005, Table 2L.

The values documented in IEC 62368-1:2018 are based on the approach for AIR CLEARANCE values as specified in the basic safety publication IEC 60664-1. The values in this standard are not based on this same approach. Since the scope of Amendment 2 is fixed, a re-evaluation of the current AIR CLEARANCE requirements is not within the scope of this review. It is however expected that this review should be done as part of the fourth edition.

The results of this review identified that the requirements for 2 MOOP according Table 13 and Table 14, or IEC 60950-1:2005, Table 2K and Table 2L will meet the requirements for 1 MOPP according to Table 12 only up to and including a WORKING VOLTAGE of 707 V d.c. / 500 V r.m.s. (Rows 1 to 7 of Table 12).

Examples:

Table 12, Table 13 and Table 14 and IEC 60950-1:2005, Table 2K and Table 2L:

Example 1 (Acceptable): A 240 V r.m.s. mains powered switch mode power supply with a WORKING VOLTAGE of 400 V r.m.s. across the switching barrier would require 3,5 mm AIR CLEARANCE for 1 MOPP according to Row 6 of Table 12. Assumptions: Overvoltage Category II, Pollution degree 2, Altitude 2 000 m.

The requirement for 2 MOOP from Table 13 would be 4,0 mm (Row 2, based voltage of 340 V peak / 240 V r.m.s., based on the RATED MAINS VOLTAGE, see 8.9.1.10) plus 0,4 mm from Table 14 (PEAK WORKING VOLTAGE, which would be a minimum of 566 V peak; Row 3) equal to 4,4 mm AIR CLEARANCE total. Assumptions: Overvoltage Category II, Pollution degree 1, 2 and 3, Altitude 2 000 m.

In this example, the minimum AIR CLEARANCE would not be less than 4,4 mm which meets the requirement of 2,5 mm from Row 6 of Table 12.

Example 2 (Unacceptable): A 240 V r.m.s. mains powered switch mode power supply with a WORKING VOLTAGE of 401 V r.m.s. across the switching barrier would require 4,5 mm AIR CLEARANCE for 1 MOPP according to Row 7 of Table 12. Assumptions: Overvoltage Category II, Pollution degree 2, Altitude 2 000 m.

The requirement for 2 MOOP from Table 13 would be 4,0 mm (Row 2, based voltage of 340 V peak / 240 V r.m.s., based on the RATED MAINS VOLTAGE, see 8.9.1.10) plus 0,4 mm from Table 14 (PEAK WORKING VOLTAGE, which would be a minimum of 567 V peak; Row 3) equal to 4,4 mm AIR CLEARANCE TOTAL. Assumptions: Overvoltage Category II, Pollution degree 1, 2 and 3, Altitude 2 000 m.

In this example, the minimum AIR CLEARANCE could be 4,4 mm which does not meet the requirement of 4,5 mm from Row 7 of Table 12.

A comparison between Table 12 and IEC 62368-1:2018, Table 10 to Table 14 (inclusive) was also performed. This comparison determined that DOUBLE INSULATION or REINFORCED INSULATION according to IEC 62368-1:2018 (which is equivalent to 2 MOOP) will meet the requirements for 1 MOPP according to Table 12 only up to and including 354 V d.c. / 250 V r.m.s.

Table 12 and IEC 62368-1:2018, Table 10 to Table 14 (inclusive):

Example 3 (Acceptable): A 240 V r.m.s. mains powered switch mode power supply with a WORKING VOLTAGE of 250 V r.m.s. across the switching barrier would require 2,5 mm AIR CLEARANCE for 1 MOPP according to Row 5 of Table 12. Assumptions: Overvoltage Category II, Pollution degree 2, Altitude 2 000 m.

The requirement for REINFORCED INSULATION (2 MOOP) from IEC 62368-1:2018 is taken as the higher value of the values determined per Procedure 1 or Procedure 2:

Procedure 1: Assume altitude of 2 000 m (no multiplication factor for AIR CLEARANCES)

- IEC 62368-1:2018, Table 10 would be 2,54 mm (Row 9, based on a temporary overvoltage of 2 000 V); Pollution degree 2
- IEC 62368-1:2018, Table 11 would be 0,14 mm (Row 1, based on peak voltage of 354 V); Pollution degree 2
- Highest value = 2,54 mm

Procedure 2: Assume altitude of 2 000 m (no multiplication factor for AIR CLEARANCES); Pollution degree 2

- IEC 62368-1:2018, Table 14 would be 3,0 mm (Row 10, based on mains transient voltage of 2 500 V)

As an alternative to Procedure 2, the value from Procedure 1 can be used with an additional electric strength test according to IEC 62368-1:2018, Table 15.

In either case the minimum AIR CLEARANCE would not be less than 2,54 mm which meets the requirement of 2,5 mm from Row 5 of Table 12.

Example 4 (Unacceptable): A 240 V r.m.s. mains powered switch mode power supply with a working voltage of 251 V r.m.s. across the switching barrier would require 3,5 mm AIR CLEARANCE for 1 MOPP according to Row 6 of Table 12. The requirement for REINFORCED INSULATION (2 MOOP) is taken as the higher value of the values determined per IEC 62368-1:2018 Procedure 1 or Procedure 2:

Procedure 1: Assume altitude of 2 000 m (no multiplication factor for AIR CLEARANCES)

- IEC 62368-1:2018, Table 10 would be 2,54 mm (Row 9, based on a temporary overvoltage of 2 000 V); Pollution degree 2
- IEC 62368-1:2018, Table 11 would be 0,14 mm (Row 1, based on peak voltage of 355 V); Pollution degree 2
- Highest value = 2,54 mm

**Procedure 2: Assume altitude of 2 000 m (no multiplication factor for AIR CLEARANCES);
Pollution degree 2**

- IEC 62368-1:2018, Table 14 would be 3,0 mm (Row 10, based on mains transient voltage of 2 500 V)

As an alternative to Procedure 2, the value from Procedure 1 can be used with an additional electric strength test according to IEC 62368-1:2018, Table 15. In this case, the minimum AIR CLEARANCE could be 2,54 mm.

Neither 3,0 mm nor 2,54 mm meet the requirement of 3,5 mm from Row 6 of Table 12.

Additional information on differences between the methods for determining AIR CLEARANCE requirements between this standard, IEC 60950-1:2005 and IEC 62368-1:2018:

A number of differences in the methods for determining the AIR CLEARANCE requirements between the standards evaluated were identified. The method specified in IEC 62368-1:2018 is more complicated than the method used according to this standard and IEC 60950-1:2005. These differences were discussed with experts from IEC TC 108 (technical committee for IEC 60950-1:2005 and IEC 62368-1:2018) to confirm these differences were properly understood by experts from IEC/TC 62. One of the differences is that WORKING VOLTAGE (d.c. or r.m.s.) is used to determine the AIR CLEARANCE requirements according to this standard or IEC 60950-1:2005. IEC 62368-1:2018 instead uses the term “voltage” which can have three different meanings depending on the circuit. “Voltage” can mean either the peak value of the working voltage, the transient overvoltage or the temporary overvoltage—in all cases, the highest value of this “voltage” is used to determine the AIR CLEARANCE requirement.

IEC TC 108 published a Technical Report (IEC TR 62368-2 [77]) which explains the process. The excerpt shown below is intended to provide a basic overview of how AIR CLEARANCE requirements according to IEC 62368-1:2018 are determined.

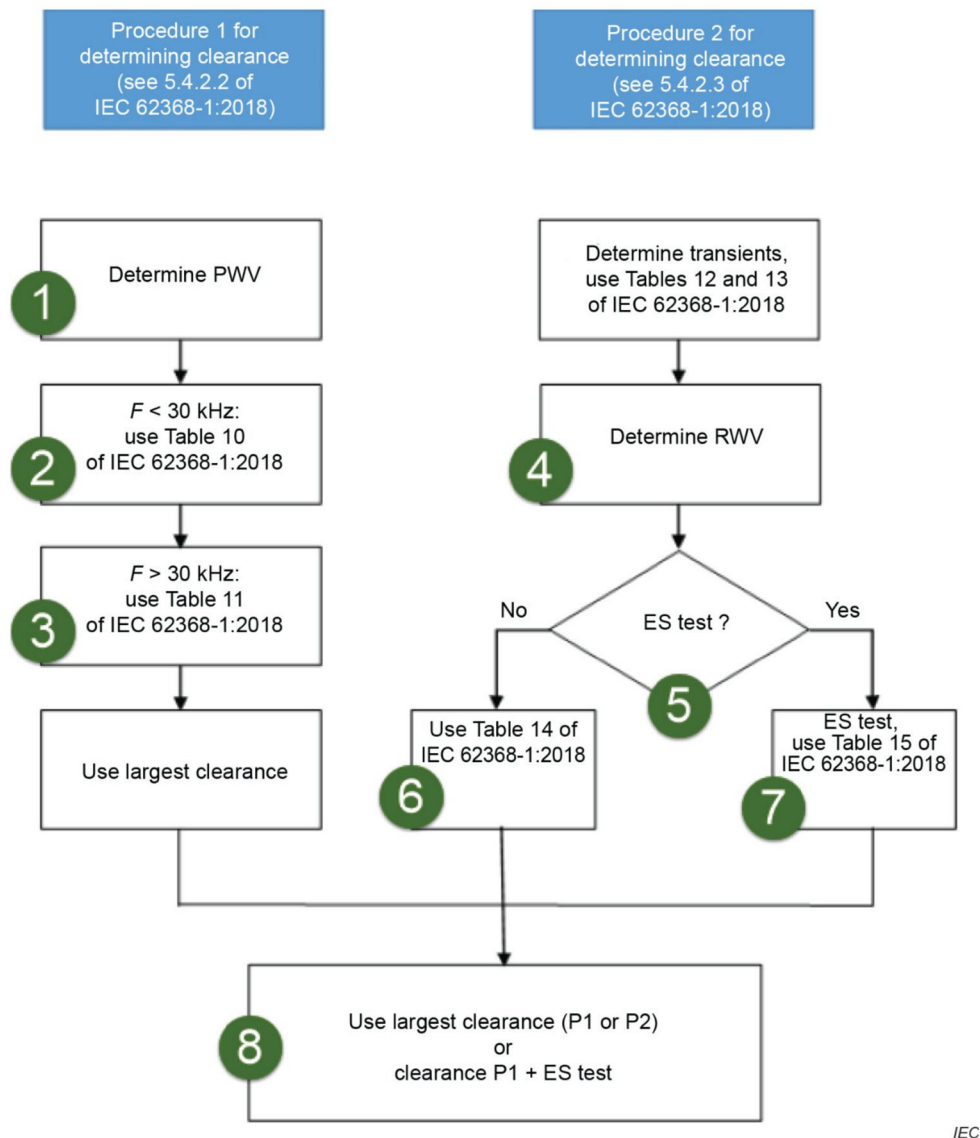

Figure A.26 – Procedure for determination of AIR CLEARANCE requirements IEC TR 62368-2:2019 [77], 5.4.2.1 (modified)

The steps 1-8 identified in Figure A.26 have been added to aid in the explanation below:

Procedure 1 (P1)

Step 1: Determine the peak of the working voltage (PWV)—for a mains connected switch mode power supply, this would be the peak value of the switching voltage, not the peak value of the SUPPLY MAINS voltage.

Step 2: IEC 62368-1:2018, Table 10 is used to determine the required AIR CLEARANCE. For mains connected equipment, this table will always be applicable. When using this table, it is the temporary overvoltage that is used in the voltage column (not the SUPPLY MAINS voltage). IEC 62368-1:2018, 5.4.2.2 specifies a temporary overvoltage of 2 000 V peak to be used if the SUPPLY MAINS voltage does not exceed 250 V (assumed to mean 250 V r.m.s.). For SUPPLY MAINS voltages above 250 V and not exceeding 600 V, the temporary overvoltage is 2 500 V peak. Using this information along with the pollution degree, IEC 62368-1:2018, Table 10 provides a value for the required AIR CLEARANCE.

Step 3: Using the peak of the WORKING VOLTAGE, IEC 62368-1:2018, Table 11 will provide a value for the required AIR CLEARANCE assuming Pollution Degree 2. For pollution degree 1 or pollution degree 3, the multiplication factor specified in the table is used.

The largest value from Step 2 or Step 3 is recorded as the requirement.

Procedure 2 (P2)

Step 4: Determine the required withstand voltage (RWV). The RWV is based on the supply circuit and is either a transient voltage, AC mains transient voltage, DC mains transient voltage or external circuit transient voltage. IEC 62368-1:2018 provides requirements for either determining this voltage based on information about the supply circuit or measuring this voltage. As an example, a SUPPLY MAINS circuit operating at 240 V r.m.s. would use the AC mains transient voltage of 2 500 V peak for an overvoltage category II supply (IEC 62368-1:2018, Table 12).

Step 5: There are 2 methods of satisfying Procedure 2, Method A or Method B:

Method A: Apply IEC 62368-1:2018, Table 14 to determine an AIR CLEARANCE value (Step 6), or

Method B: Apply IEC 62368-1:2018, Table 15 to determine an electric strength test value to be used (Step 7).

Step 6: Take the RWV value determined in Step 4 and determine the required AIR CLEARANCE from IEC 62368-1:2018, Table 14 using the RWV along with the pollution degree. Skip Step 7.

Step 7: Use IEC 62368-1:2018, Table 15 to determine the electric strength test voltage using the RWV determined in Step 4.

Step 8: Determine the required AIR CLEARANCE—this is either the highest value determined using Procedure 1 (Step 3) and Procedure 2 (Step 6) or the value from Procedure 1 (Step 3) with the electric strength test (Step 7).

Subclause 8.5.3 – MAXIMUM MAINS VOLTAGE

Replace, in the final sentence of the existing first paragraph, "was (and remains) 250 V," with "is 240 V,".

Replace, in the existing third paragraph, "250 V" with "240 V".

Delete the existing fourth paragraph.

Subclause 8.5.4 – WORKING VOLTAGE

Delete the existing third paragraph.

Subclause 8.6.1 – Applicability of requirements

Replace, in the existing paragraph, the reference to "IEC 60950-1" with "IEC 60950-1:2005, IEC 60950-1:2005/AMD1:2009 and IEC 60950-1:2005/AMD2:2013".

Subclause 8.6.4 a)

Add, after the existing seventh paragraph, added by Amendment 1, the following text:

If the MANUFACTURER does not supply/specify a DETACHABLE POWER SUPPLY CORD, the RESPONSIBLE ORGANIZATION should take into account the limits of 8.6.4.

Subclause 8.8.2 – Distance through solid insulation or use of thin sheet material

Replace, in the existing fourth paragraph, "IEC 60950-1" with "IEC 60950-1:2005".

Replace, in each of the existing four bullets following the fourth paragraph, "IEC 60950-1" with "IEC 60950-1:2005".

Replace, in the existing fifth paragraph, "IEC 60950-1" with "IEC 60950-1:2005".

Subclause 8.8.3 – Dielectric strength

Replace, in the existing fifth paragraph, the reference to "IEC 60950-1" with "IEC 60950-1:2005".

Add, after the existing sixth paragraph, the following text:

Information regarding the incorporation of requirements from IEC 62368-1:2018 in Amendment 2:

According to IEC 62368-1:2018, the minimum dielectric strength requirement for mains operated equipment with a mains supply voltage up to and including 250 V r.m.s for REINFORCED INSULATION (2 MOOP) is 4 kV (IEC 62368-1:2018, Table 27). Table 6 was analyzed, and it was determined that a WORKING VOLTAGE (peak or d.c.) up to 1 293 V requires a dielectric strength test of less than or equal to 4 kV peak for 1 MOPP.

According to IEC 62368-1:2018, the minimum dielectric strength requirement for mains operated equipment with a mains supply voltage above 250 V r.m.s up to and including 600 V r.m.s. for REINFORCED INSULATION (2 MOOP) IS 5 kV (IEC 62368-1:2018, Table 27). Table 6 was analyzed, and it was determined that a WORKING VOLTAGE (peak or d.c.) up to 2 172 V requires a dielectric strength test of less than or equal to 5 kV peak for 1 MOPP.

For higher PEAK WORKING VOLTAGES, information regarding the equipment/sub-assembly/component that was tested according to IEC 62368-1:2018 needs to be reviewed to determine if the applied electric strength test (IEC 62368-1:2018, Table 25 to Table 27 (inclusive)) for REINFORCED INSULATION meets the minimum requirement from Table 6 if 1 MOPP is necessary.

A direct comparison between the requirements of this standard and IEC 62368-1:2018 for dielectric strength (electric strength is the term used in IEC 62368-1:2018) is not possible without knowing the reference "voltage". The "voltage" is either the expected transient voltage (IEC 62368-1:2018, Table 25), peak of the working voltage and recurring peak voltages (IEC 62368-1:2018, Table 26) or the temporary overvoltage (IEC 62368-1:2018, Table 27). Knowing these voltages allows the values from each table to be determined, the requirement applied is the highest value from the three tables; but for equipment connected to a nominal SUPPLY MAINS system up to and including 250 V r.m.s., the minimum test voltage will be 4 kV peak and for a nominal SUPPLY MAINS system voltage above 250 V r.m.s up to and including 600 V r.m.s. the minimum test voltage will be 5 kV peak.

Subclause 8.9 – CREEPAGE DISTANCES and AIR CLEARANCES

Replace, in the existing third paragraph, the reference to "IEC 60950-1" with "IEC 60950-1:2005".

Replace, in the existing paragraph preceding Table A.1, the first sentence with "Table 16 of the second edition of IEC 60601-1 was split into five tables in this standard (Table 12 to Table 16 inclusive)."

Subclause 8.9.1 – Values

Replace, in the existing second paragraph, "IEC 60950-1" with "IEC 60950-1:2005".

Add, after the existing Table A.2, the following rationale:

Subclause 8.9.1.2 – CREEPAGE DISTANCES and AIR CLEARANCES complying with IEC 60950-1 or IEC 62368-1

During the review of the differences between the requirements of this standard and IEC 62368-1:2018 a scenario was identified where the AIR CLEARANCE values required by IEC 62368-1:2018 could be significantly lower than the values currently required by this standard for MOOP. It was determined that this scenario would lead to AIR CLEARANCE values that are too small for ME EQUIPMENT and that sub-assemblies/components utilizing this construction would not be acceptable as part of ME EQUIPMENT.

This scenario is specific to sub-assemblies/components specifically designed for use with a SUPPLY MAINS that is free from transient voltages. For example, a d.c. power supply in an ambulance that is used to generate a 240 V r.m.s. supply voltage (transient free). In this example, following the requirements from IEC 62368-1:2018, Table 10 and Table 14 (Procedure 1 and Procedure 2) would give the required AIR CLEARANCE of 0,4 mm due to the nature of the supply (transient free).

IEC 60601-1 applies the same requirements to SUPPLY MAINS regardless of the existence of transient overvoltages in the SUPPLY MAINS. In this scenario the requirement for AIR CLEARANCE for 2 MOOP would be 4,0 mm for primary circuits (Table 13, Row 2). Given the large difference in requirements, it has been determined that sub-assemblies/components designed specifically for use in transient-free SUPPLY MAINS that have been evaluated for compliance with IEC 62368-1:2018 alone would not be acceptable and the requirements of Table 12 to Table 16 (inclusive) would additionally apply.

It is acknowledged that the probability of a sub-assembly/component being designed specifically for this application is likely to be low. Additionally, any sub-assembly/component (e.g. power supply) that was intended for a traditional SUPPLY MAINS connection would meet the higher requirements based on the transient voltage or temporary overvoltage and would be acceptable.

Subclause 8.9.3 – Spaces filled by insulating compound

Replace, in the existing second paragraph, "IEC 60950-1" with "IEC 60950-1:2005".

Replace, in the existing third paragraph, "IEC 60950-1" with "IEC 60950-1:2005" in two places.

Subclause 9.7 – Pressure vessels and parts subject to pneumatic and hydraulic pressure

Replace, in the existing third paragraph of list item a), the defined term "MAXIMUM PERMISSIBLE WORKING PRESSURE" with "MAXIMUM EQUIPMENT PRESSURE" in three places.

Replace, in the existing fourth paragraph of list item a), the defined term "MAXIMUM PERMISSIBLE WORKING PRESSURE" with "MAXIMUM EQUIPMENT PRESSURE".

Replace, in the existing second paragraph of list item b), the defined term "MAXIMUM PERMISSIBLE WORKING PRESSURE" with "MAXIMUM EQUIPMENT PRESSURE".

Replace, in the existing third paragraph of list item c), the defined term "MAXIMUM PERMISSIBLE WORKING PRESSURE" with "MAXIMUM EQUIPMENT PRESSURE".

Replace, in the existing third paragraph of list item d), the defined term "MAXIMUM PERMISSIBLE WORKING PRESSURE" with "MAXIMUM EQUIPMENT PRESSURE".

Subclause 10.1.1 – ME EQUIPMENT not intended to produce diagnostic or therapeutic X-radiation

Replace, in the existing first paragraph, the first reference to "IEC 60950-1:2001" with "IEC 60950-1:2005" and delete the third sentence.

Add, after the existing first paragraph, the following text:

IEC 62368-1:2018 is replacing IEC 60950-1 and was incorporated into this standard as part of Amendment 2. Based on a review of the test procedures and requirements according to IEC 60950-1:2005 and IEC 62368-1:2018, it was determined that there are differences in the measurement procedures and acceptance criteria. IEC 62368-1:2018 adds an additional requirement for measurements under single fault conditions. Additionally, IEC 62368-1:2018 adds a requirement that images generated during the test be intelligible (which is defined). IEC 62368-1:2018 does not include the 50 mm measuring surface of the OPERATOR access area which is specified in IEC 60950-1:2005. The limits are the same between IEC 60950-1:2005 and IEC 62368-1:2018.

Subclause 10.4 – Lasers

Replace, in the existing first sentence of the first paragraph added by Amendment 1, "IEC 60825-1" with "IEC 60825-1:2014" and add, after the first sentence, the following:

This includes laser diodes.

Replace the existing second paragraph added by Amendment 1 with:

Any laser product is exempt from all further requirements of IEC 60825-1 if classification by the laser manufacturer demonstrates that the emission level does not exceed the AEL (Accessible Emission Limit) of Class 1 under all conditions of operation, maintenance, service and failure.

Replace, in the existing third paragraph added by Amendment 1, "In previous editions" with "In older editions".

Add, after the existing third paragraph added by Amendment 1, the following heading:

Subclauses 10.5, 10.6 and 10.7 – Other visible electromagnetic, infrared and ultraviolet radiation

Replace, in the existing fourth paragraph added by Amendment 1, "IEC 62471 gives guidance" with "IEC 62471 [67] gives guidance".

Add, after the existing fourth paragraph added by Amendment 1, the following text:

Where appropriate, IEC 60601-2-57 [75] is used for ME EQUIPMENT incorporating non-laser light sources intended to create non-visual photobiological effects.

Subclause 11.1.3 – Measurements

Replace the existing Figure A.22, modified by Amendment 1, with:

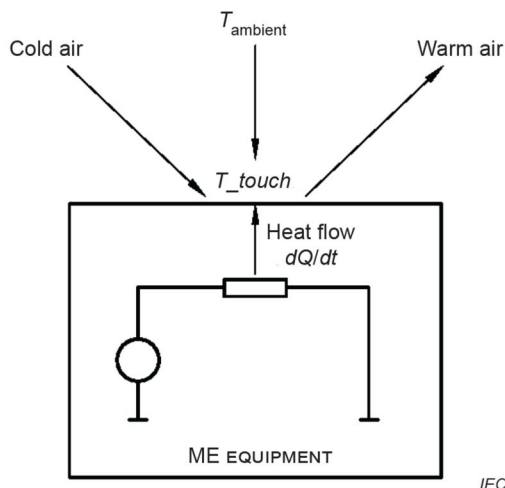

Subclause 11.3 – Constructional requirement for fire ENCLOSURES of ME EQUIPMENT

Delete, in the first sentence of the existing first paragraph, "from IEC 61010-1 [22]".

Delete the existing second, third and fourth paragraphs, modified by Amendment 1.

Replace the existing fifth paragraph with:

IEC 61010-1:2010 [22], subclause 9.3.2, requires wire insulation to retard flame propagation when used inside a fire ENCLOSURE. Wire with a flammability rating of UL 2556 [72] VW-1 or equivalent is considered to meet this requirement. In case of doubt, wires are tested according to the applicable requirements of IEC 60332-1-2 [55] or IEC 60332-2-2 [56]. These wire flame resistance requirements are considered acceptable for ME EQUIPMENT and ME SYSTEMS.

Subclause 11.6.3 – Spillage on ME EQUIPMENT and ME SYSTEMS

Replace, in the existing second paragraph, modified by Amendment 1, the first occurrence of "IEC 62366" with "IEC 62366-1 [76]" and the second occurrence with "IEC 62366-1".

Delete the existing final paragraph.

Subclause 11.8 – Interruption of the power supply / SUPPLY MAINS to ME EQUIPMENT

Replace, in the existing second paragraph, "Tables 210 and 211 of IEC 60601-1-2:2001" with "Table 5 of IEC 60601-1-2:2014 and IEC 60601-1-2:2014/AMD1:2020".

Subclause 13.1.2 – Emissions, deformation of ENCLOSURE or exceeding maximum temperature

Add, after the existing third paragraph, the following text:

The NOTE in 13.1.2 is related to the 15 W limit when the investigated part of the supply circuit is a battery. It is intended to alert the reader that potentially hazardous energies inside the battery need to be considered. Therefore, the power dissipation needs to be measured directly on the output contacts of the battery, regardless of any external protection means.

Replace, in the existing fifth paragraph, modified by Amendment 1, the reference to "IEC 60950-1" with "IEC 60950-1:2005".

Replace, in the existing sixth paragraph, modified by Amendment 1 the reference to "IEC 60950-1" with "IEC 60950-1:2005".

Replace the existing seventh paragraph, modified by Amendment 1, with:

Since facilities where ME EQUIPMENT compliant with this standard is used will also contain information technology equipment and such equipment can be part of ME EQUIPMENT or ME SYSTEMS, it would be unreasonable to require the ME EQUIPMENT to offer a different level of protection against ignition than does the other equipment used in the same environment. Other end-product standards can provide an alternative means of protection against ignition.

Replace, in the existing first dash following the ninth paragraph, modified by Amendment 1, "FV1" with "V-1".

Left align the existing final paragraph modified by Amendment 1 and add the following new rationale:

Subclause 13.1.2 Dashes 4 and 5

Interpretation Sheet 3 to IEC 60601-1 (IEC 60601-1:2005/ISH3:2013) allows surface temperatures up to 105 °C in SINGLE FAULT CONDITION under some circumstances. This is not considered appropriate for all type of materials, e.g. metal. Therefore, the requirement for maximum temperatures in SINGLE FAULT CONDITION for ACCESSIBLE PARTS are partially based on the state-of-the art standard IEC 62368-1:2018.

The test condition is different in IEC 62368-1:2018, where the limits are based on 25 °C ambient temperature, rather than the maximum specified ambient temperature. Based on review of ISO 13732-1:2006 [81], the temperature limits extracted from IEC 62368-1:2018 should be applied regardless of ambient temperature, since accepting higher surface temperatures could lead to a potential burn HAZARD resulting in an unacceptable HARM.

For the same reason, the limit for glass, porcelain and vitreous material has been set to 90 °C (instead of 95 °C) in this standard.

Subclause 14.1 – General

Replace, in the existing first paragraph, modified by Amendment 1, "IEC 62304:2006" with "IEC 62304:2006 and IEC 62304:2006/AMD1:2015" in two places.

Subclause 14.4 – PEMS DEVELOPMENT LIFE-CYCLE

*Replace, in the existing paragraph modified by Amendment 1 following the heading **Framework**, "IEC 62304:2006" with "IEC 62304:2006 and IEC 62304:2006/AMD1:2015".*

Subclause 15.3.2 – Push test

Replace, in the existing first paragraph, the reference to "IEC 60950-1" with "IEC 60950-1:2005".

Subclause 15.5.3 – Construction of transformers used to provide separation as required by 8.5

Replace, in the existing second paragraph, modified by Amendment 1, "IEC 60950-1:2005" with "IEC 60950-1:2005, IEC 60950-1:2005/AMD1:2009 and IEC 60950-1/AMD2:2013".

Add, after the existing second paragraph, modified by Amendment 1, the following text:

It was noticed during the evaluation, that transformers complying with IEC 62368-1:2018, will use FIW (fully insulated winding wire) instead of TIW (triple-insulated winding wire). As a result

of the comparison, it was considered that the use of this FIW is acceptable for MEANS OF OPERATOR PROTECTION (MOOP) only. The use of FIW as MEANS OF PATIENT PROTECTION (MOPP) needs further investigation during the development of the fourth edition before an alternative test method to comply with the requirements for MOPP can be implemented in the normative text of Annex L.

Subclause 16.9.2.2 – PROTECTIVE EARTH CONNECTIONS in ME SYSTEMS

Add, after the existing first paragraph, modified by Amendment 1, the following text:

In the design of some ME SYSTEMS, pathway of a fault current caused by a live part to a PROTECTIVE EARTH CONNECTION fault is protected by additional intermediate circuit breakers or fuses. Provided that such intermediate circuit breakers or fuses have a current ratings 13 A or lower, a total protective earth impedance up to 400 mΩ is acceptable.

In the presence of a fault from SUPPLY MAINS to PROTECTIVELY EARTHED parts for certain allowed SUPPLY MAINS installation configurations, a touch voltage can appear on earthed conductive ACCESSIBLE PARTS for an extended time if the protective earth resistance is greater than 400 mΩ and the SUPPLY MAINS fuse is greater than 13 A.

Data in IEC 60479-1 [73] indicates that it is possible for such touch voltage (which results in a touch current) combined with an extended disconnection time present a RISK of ventricular fibrillation (see Figure 20 and Table 11 in IEC 60479-1:2018).

Replace the third sentence of the existing second paragraph, modified by Amendment 1, with:

This might require measures such as using short power supply cords within the ME SYSTEM and using a POWER SUPPLY CORD for the MULTIPLE SOCKET-OUTLET of greater cross-sectional area than is necessary for current carrying purposes to reduce its protective earth impedance.

Annex B – Sequence of testing

B.6 ME EQUIPMENT identification, marking and documents

Replace, in the existing paragraph, "7.8.2" with "7.9".

B.36 VERIFICATION of markings

Replace, in the existing paragraph, "7.8.2" with "7.6".

Annex C – Guide to marking and labelling requirements for ME EQUIPMENT and ME SYSTEMS

C.1 Marking on the outside of ME EQUIPMENT, ME SYSTEMS or their parts

Replace, in the existing first paragraph, "safety signs" with "SAFETY SIGNS".

Annex D – Symbols on marking

Replace, in the existing first paragraph, "safety signs" with "SAFETY SIGNS" in two places.

Replace, in the existing second paragraph, "safety sign" with "SAFETY SIGN", and "safety signs" with "SAFETY SIGNS".

Replace, in the existing third paragraph, "safety sign" with "SAFETY SIGN".

Replace, in the existing fourth paragraph, "safety signs" with "SAFETY SIGNS".

Replace, in the existing fifth paragraph, modified by Amendment 1, "safety sign" with "SAFETY SIGN".

Replace, in the existing sixth paragraph, "safety signs" with "SAFETY SIGNS".

Table D.1 – General symbols

Replace, in the existing Row 10, "safety sign" with "SAFETY SIGN" in three places.

Table D.2 – Safety signs

Replace, in the existing title, "Safety signs" with "SAFETY SIGNS", and in the existing heading, "Safety sign" with "SAFETY SIGN".

Annex G – Protection against HAZARDS of ignition of flammable anaesthetic mixtures

G.2.5 ME EQUIPMENT specified for use with FLAMMABLE ANAESTHETIC MIXTURE WITH OXYGEN OR NITROUS OXIDE

Replace, in the existing compliance paragraph, modified by Amendment 1, "...Clause G.3, G.4 and G.5" with "...Clauses G.3, G.4, G.5 and G.6".

Figure G.6 – Maximum allowable current I_{ZL} as a function of the inductance L_{max} measured in an inductive circuit with the most flammable mixture of ether vapour with oxygen

Replace the existing figure with the following new figure:

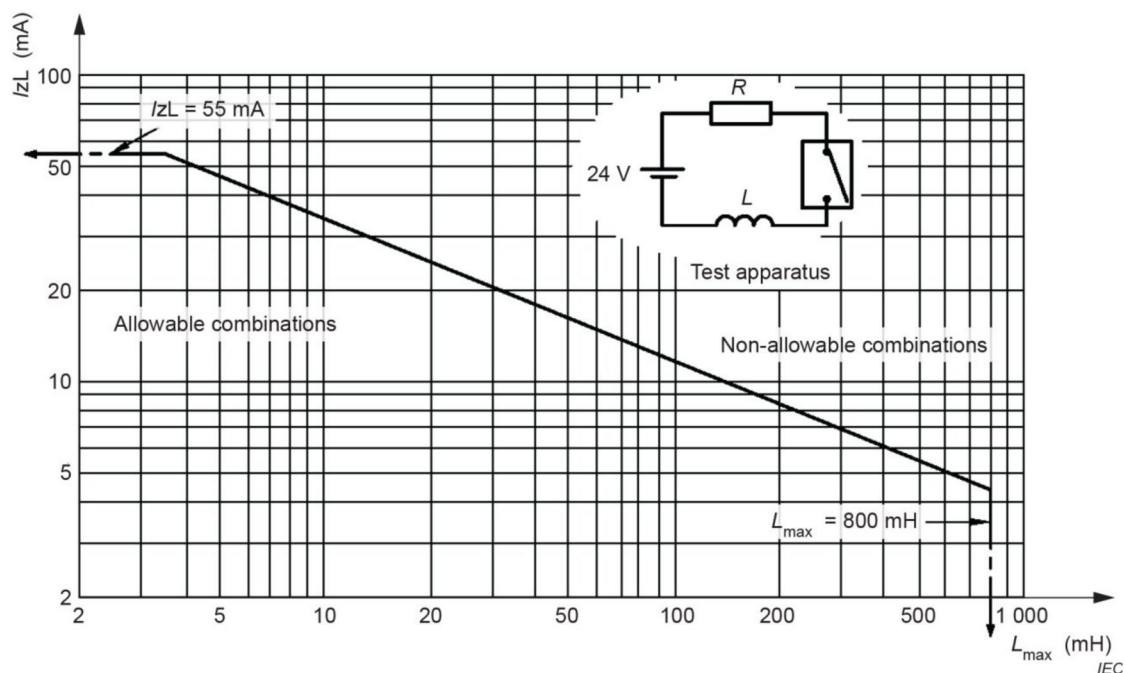

Annex H – PEMS structure, PEMS DEVELOPMENT LIFE-CYCLE and documentation

H.7.2 Causes of HAZARDOUS SITUATIONS associated with IT-NETWORKS

Replace, in the existing second paragraph, modified by Amendment 1, "Annex E of ISO 14971:2007" with "Annex C of ISO 14971:2019".

Replace the existing introductory sentence starting with "Supplementing Annex C of ISO 14971:2007", modified by Amendment 1, with:

The following questions should be taken into account when identifying the characteristics that could impact on safety:

Annex L – Insulated winding wires for use without interleaved insulation (see 8.8.2)

L.1 Introduction

Add, after the existing second paragraph, the following text:

For insulated winding wires used as MEANS OF OPERATOR PROTECTION (MOOP), an alternative test method according to IEC 62368-1:2018, G.5.3.4 is considered acceptable.

Bibliography

Replace existing Bibliography reference "[11] IEC 60479-1:1994, *Effects of current on human beings and livestock – Part 1: General aspects*" with "[11] Void".

Add the following to the end of the Bibliography:

- [73] IEC 60479-1:2018, *Effects of current on human beings and livestock – Part 1: General aspects*
- [74] IEC 60601-1:1988, *Medical electrical equipment – Part 1: General requirements for safety*
Amendment 1:1991
Amendment 2:1995
- [75] IEC 60601-2-57, *Medical electrical equipment – Part 2-57: Particular requirements for the basic safety and essential performance of non-laser light source equipment intended for therapeutic, diagnostic, monitoring and cosmetic/aesthetic use*
- [76] IEC 62366-1:2015, *Medical devices – Part 1: Application of usability engineering to medical devices*
- [77] IEC TR 62368-2:2019, *Audio/video, information and communication technology equipment – Part 2: Explanatory information related to IEC 62368-1:2018*
- [78] ISO 2409, *Paints and varnishes – Cross-cut test*
- [79] ISO 4624, *Paints and varnishes – Pull-off test for adhesion*
- [80] ISO 10524-1:2018, *Pressure regulators for use with medical gases – Part 1: Pressure regulators and pressure regulators with flow-metering devices*
- [81] ISO 13732-1:2006, *Ergonomics of the thermal environment – Methods for the assessment of human responses to contact with surfaces – Part 1: Hot surfaces*
- [82] UL 746C, *Standard for Polymeric Materials – Use in Electrical Equipment Evaluations*

INDEX OF ABBREVIATIONS AND ACRONYMS

Add, following the existing fourteenth row "FDDI", the following new row:

| | |
|-----|--------------------------------|
| FEP | Fluorinated ethylene propylene |
|-----|--------------------------------|

Delete the existing sixteenth row "FV", added by Amendment 1.

Add, following the existing twenty-third row "IT", the following new row:

| | |
|------|------------------|
| KPaG | Kilopascal Gauge |
|------|------------------|

Add the following new row at the end of the table:

| | |
|-----|--|
| V-x | Flammability classification according to IEC 60695-11-10 |
|-----|--|

Vertical line of small characters on the right edge of the page.

Copyright International Electrotechnical Commission

INTERNATIONAL
ELECTROTECHNICAL
COMMISSION

3, rue de Varembe
PO Box 131
CH-1211 Geneva 20
Switzerland

Tel: + 41 22 919 02 11
info@iec.ch
www.iec.ch



医课汇
公众号
专业医疗器械资讯平台
WECHAT OF
HLONGMED



hlongmed.com
医疗器械咨询服务
MEDICAL DEVICE
CONSULTING
SERVICES



医课培训平台
医疗器械任职培训
WEB TRAINING
CENTER



医械宝
医疗器械知识平台
KNOWLEDG
ECENTEROF
MEDICAL DEVICE



MDCPP.COM
医械云专业平台
KNOWLEDG
ECENTEROF MEDICAL
DEVICE